

TB 9-2320-273-13&P-2

TECHNICAL BULLETIN

**OPERATOR'S, UNIT, AND DIRECT SUPPORT
MAINTENANCE MANUAL, INSTALLATION INSTRUCTIONS, AND
REPAIR PARTS AND SPECIAL TOOLS LIST (RPSTL)**

FOR

**TRUCK, TRACTOR, LINE HAUL, 6X4, M915P1
NSN 2320-01-525-7451**

**TRUCK, TRACTOR, LINE HAUL, 6X4, M915A1P1
NSN 2320-01-525-7444**

**TRUCK, TRACTOR, LIGHT EQUIPMENT TRANSPORTER, 6X6 WINCH,
M916P1
NSN 2320-01-531-2626**

**TRUCK CHASSIS, 8X6, FOR 20 TON DUMP TRUCK, M917P1
NSN 2320-01-531-2623**

**TRUCK, TRACTOR, MEDIUM EQUIPMENT TRANSPORTER, 8X6,
WITH WINCH, M920P1
NSN 2320-01-531-2638**

WITH

AIR CONDITIONING KIT



DISTRIBUTION STATEMENT A - Approved for public release; distribution is unlimited.

HEADQUARTERS, DEPARTMENT OF THE ARMY

MARCH 2008

WARNING SUMMARY

This warning summary contains general safety warnings and hazardous materials warnings that must be understood and applied during operation and maintenance of this equipment. Failure to observe these precautions may cause serious injury or death to personnel. Also included are explanations of safety and hazardous materials icons used within this technical bulletin.



BIOLOGICAL - Abstract symbol bug shows that a material may contain bacteria or viruses that present a danger to life or health.



CHEMICAL - Drop of liquid on hand shows that the material will cause burns or irritation to human skin or tissue.



ELECTRICAL - Electrical wire to arm with electricity symbol running through human body shows that shock hazard is present.



EYE PROTECTION - Person with goggles shows that the material will injure the eyes.



FIRE - Flame shows that a material may ignite and cause burns.



FLYING PARTICLES - Arrows bouncing off face with face shield shows that particles flying through the air will harm face.



HEAVY PARTS - Hand with heavy object on top shows that heavy parts can crush and harm.



HEAVY PARTS - Heavy object on human figure shows that heavy parts present a danger to life or limb.



HYDRAULIC FLUID PRESSURE - Hydraulic fluid spraying human hand shows that fluid escaping under great pressure can cause injury or death to personnel.



RADIOACTIVE - Identifies a material that emits radioactive energy and can injure human tissue or organs.



SLICK FLOOR - Wavy line on floor with legs prone shows that slick floor presents a danger from falling.



VAPOR - Human figure in a cloud shows that material vapors present a danger to life or health.

FOR INFORMATION ON FIRST AID, REFER TO FM 4-25.11.



WARNING

ADHESIVES AND SEALANTS



Use caution when using adhesives and sealants. Prolonged inhalation of vapors can cause lung irritation. Contact with skin can cause dermatitis. Wear gloves and safety goggles and use product in a well-ventilated area away from open flame. If ingested, keep individual calm and seek medical attention. **DO NOT** induce vomiting. If contact with skin or eyes is made, flush thoroughly with water. Dispose of cleanup rags IAW local policy and ordinances. Failure to follow this warning may cause injury to personnel.



WARNING

COMPRESSED AIR

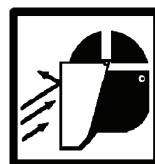

Particles blown by compressed air are hazardous. **DO NOT** exceed 15 psi (103 kPa) nozzle pressure when drying parts with compressed air. Use a maximum of 30 psi (207 kPa) when cleaning components. **DO NOT** direct compressed air against human skin. Make sure air stream is directed away from user and other personnel in the area. To prevent injury, user must wear protective goggles or face shield. Failure to follow this warning may result in injury or death to personnel.



WARNING

ELECTRICAL

Before removing any component of electrical system, be sure battery disconnect switch is in OFF position. Remove all jewelry before working on electrical system. Failure to follow this warning may cause injury to personnel.



WARNING

HEAVY COMPONENTS

Use extreme caution when handling heavy parts. Provide adequate support and use assistance during procedure. Ensure that any lifting device used is in good condition and of suitable load capacity. Keep clear of heavy parts supported only by lifting device. Failure to follow this warning may cause injury or death to personnel.



WARNING
NBC EXPOSURE



- If NBC exposure is suspected, personnel wearing protective equipment must handle all air cleaner media. Consult your NBC Officer or NBC NCO for appropriate handling or disposal procedures.
- NBC contaminated filters must be handled using adequate precautions and must be disposed of by trained personnel.
- Wear eye protection while removing filter.
- Failure to follow these warnings may result in injury or death to personnel.

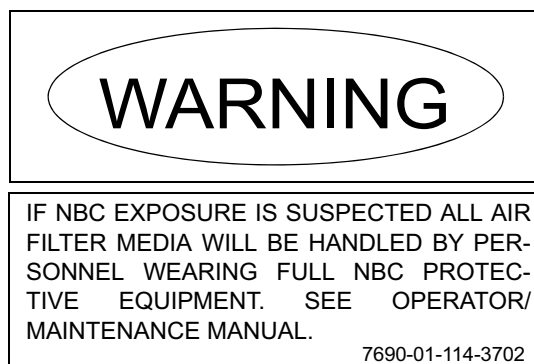

To order this NBC decal use:

National Stock Number (NSN) - 7690-01-114-3702
Part Number (PN) - 12296626
Commercial and Government Entity Code (CAGEC) - 19207



WARNING
RECEIVER/DRYER

Receiver/dryer unit will fall when clamps are loosened. Support receiver/dryer while loosening clamps. Failure to comply may cause injury to personnel.



WARNING

Only service refrigerant in a well-ventilated area. Personal injury or death can result from inhaling refrigerant.



- Contact with refrigerant can cause frostbite. Keep hands and face away to prevent personal injury.
- Protective face shield must always be worn when refrigerant lines are opened, even if the gauges indicate the system is empty.
- Always use caution if a fitting is removed. Slowly loosen the fitting. If the system is still under any pressure, release it slowly in a well-ventilated area.
- DO NOT smoke when servicing A/C or wherever refrigerant gas may be present.
- Failure to follow these warnings may result in injury or death to personnel.



- Solvent cleaning compound MIL-PRF-680 Type II and III may be irritating to the eyes and skin. Use protective gloves and goggles. Use in well-ventilated areas. Use respirator as needed. Accidental ingestion can cause irritation of digestive tract and respiratory tract, may cause lung and central nervous system damage. Can be fatal if swallowed. Inhalation of high/massive concentrations can cause coma or be fatal. First aid for ingestion: do not induce vomiting. Seek immediate medical attention. First aid for skin contact: remove contaminated clothing. Wash skin thoroughly with soap and water. If symptoms persist, seek medical attention. First aid for eye contact: flush with water for 15 minutes or until irritation subsides. If symptoms persist, seek medical attention. First aid for inhalation: move to fresh air. If not breathing, provide artificial respiration. If symptoms persist, seek medical attention. Keep away from open flames and other sources of ignition.
- The flashpoint for type II solvent cleaning compound is 141-198°F (61-92°C) and type III is 200-241°F (93-116°C).
- Improper cleaning methods and use of unauthorized cleaning solvents may injure personnel and damage equipment.
- Fire extinguishers should be placed nearby when using solvent cleaning compound.
- Cloths or rags saturated with solvent cleaning compound must be disposed of IAW authorized facilities' procedures.
- Eye shields must be worn when cleaning with a wire brush. Flying rust and metal particle may cause injury.
- Failure to follow these warnings may result in injury or death to personnel.

WARNING
HAZARDOUS WASTE

When servicing this vehicle, performing maintenance, or disposing of materials such as engine coolant, hydraulic fluid, lubricants, battery acids or batteries, and CARC paint, consult your unit/local hazardous waste disposal center or safety office for local regulatory guidance. If further information is needed, please contact The Army Environmental Hotline at 1-800-872-3845.

WARNING
WELDING

To ensure survivability of personnel, welding repairs on armor set are NOT authorized. If armor plates are damaged, they must be replaced. Failure to follow this warning may cause failure of armor, resulting in injury or death to personnel.

LIST OF EFFECTIVE PAGES/WORK PACKAGES

Date of issue for original manual is:

Original 31 March 2008

Total number of pages for front and rear matter is 20 and total number of work packages is 29 consisting of the following:

Page/WP No.	*Change No.	Page/WP No.	*Change No.
Front cover	0	WP 0028 00 (6 pp.)	0
a to f	0	WP 0029 00 (16 pp.)	0
i to vi	0	Index-1 to Index-2	0
Ch. 1 title page	0	Foldout FP-1/(FP-2 Blank)	0
WP 0001 00 (4 pp.)	0	Metric conversion chart	0
WP 0002 00 (4 pp.)	0	Back cover	0
WP 0003 00 (2 pp.)	0		
Ch. 2 title page	0		
WP 0004 00 (2 pp.)	0		
WP 0005 00 (2 pp.)	0		
WP 0006 00 (2 pp.)	0		
WP 0007 00 (2 pp.)	0		
Ch. 3 title page	0		
WP 0008 00 (4 pp.)	0		
WP 0009 00 (8 pp.)	0		
WP 0010 00 (2 pp.)	0		
Ch. 4 title page	0		
WP 0011 00 (6 pp.)	0		
WP 0012 00 (2 pp.)	0		
WP 0013 00 (26 pp.)	0		
Ch. 5 title page	0		
WP 0014 00 (6 pp.)	0		
WP 0015 00 (10 pp.)	0		
WP 0016 00 (6 pp.)	0		
WP 0017 00 (24 pp.)	0		
WP 0018 00 (8 pp.)	0		
WP 0019 00 (4 pp.)	0		
WP 0020 00 (14 pp.)	0		
WP 0021 00 (16 pp.)	0		
Ch. 6 title page	0		
WP 0022 00 (2 pp.)	0		
WP 0023 00 (4 pp.)	0		
WP 0024 00 (2 pp.)	0		
WP 0025 00 (4 pp.)	0		
WP 0026 00 (4 pp.)	0		
WP 0027 00 (20 pp.)	0		

* Zero in this column indicates an original page or work package.

TECHNICAL BULLETIN
TB 9-2320-273-13&P-2

HEADQUARTERS
DEPARTMENT OF THE ARMY
Washington, D.C., 31 March 2008

TECHNICAL BULLETIN

**OPERATOR'S, UNIT, AND DIRECT SUPPORT
MAINTENANCE MANUAL, INSTALLATION INSTRUCTIONS, AND
REPAIR PARTS AND SPECIAL TOOLS LIST (RPSTL)**

FOR

**TRUCK, TRACTOR, LINE HAUL, 6X4, M915P1
NSN 2320-01-525-7451**

**TRUCK, TRACTOR, LINE HAUL, 6X4, M915A1P1
NSN 2320-01-525-7444**

**TRUCK, TRACTOR, LIGHT EQUIPMENT TRANSPORTER, 6X6 WINCH,
M916P1
NSN 2320-01-531-2626**

**TRUCK CHASSIS, 8X6, FOR 20 TON DUMP TRUCK, M917P1
NSN 2320-01-531-2623**

**TRUCK, TRACTOR, MEDIUM EQUIPMENT TRANSPORTER, 8X6,
WITH WINCH, M920P1
NSN 2320-01-531-2638**

WITH

AIR CONDITIONING KIT

Current as of January 2008

REPORTING ERRORS AND RECOMMENDING IMPROVEMENTS

You can help improve this publication. If you find any mistakes or if you know of a way to improve the procedures, please let us know. Submit your DA Form 2028 (Recommended Changes to Equipment Technical Publications), through the Internet, on the Army Electronic Product Support (AEPS) website. The Internet address is <https://aeprs.ria.army.mil>. The DA Form 2028 is located under the Public Applications section in the AEPS Public Home Page. Fill out the form and click on SUBMIT. Using this form on the AEPS will enable us to respond quicker to your comments and better manage the DA Form 2028 program. You may also mail, fax or E-mail your letter or DA Form 2028 direct to: AMSTA-LC-LMPP/TECH PUBS, TACOM-RI, 1 Rock Island Arsenal, Rock Island, IL 61299-7630. The E-mail address is ROCK-TACOM-TECH-PUBS@conus.army.mil. The fax number is DSN 793-0726 or Commercial (309) 782-0726.

DISTRIBUTION STATEMENT A - Approved for public release; distribution is unlimited.

Table of Contents

	Page Number
Warning Summary	a
How To Use This Technical Bulletin	v
CHAPTER 1 GENERAL INFORMATION, EQUIPMENT DESCRIPTION AND DATA, AND THEORY OF OPERATION	
WP 0001 00 General Information	0001 00-1
WP 0002 00 Equipment Description and Data.	0002 00-1
WP 0003 00 Theory of Operation	0003 00-1
CHAPTER 2 OPERATOR INSTRUCTIONS	
WP 0004 00 Description and Use of Operator Controls	0004 00-1
WP 0005 00 Operation Under Usual Conditions	0005 00-1
WP 0006 00 Operation Under Unusual Conditions	0006 00-1
WP 0007 00 Decal and Data Plate Guide.	0007 00-1
CHAPTER 3 OPERATOR MAINTENANCE INSTRUCTIONS	
WP 0008 00 Operator Preventive Maintenance Checks and Services (PMCS) Introduction	0008 00-1
WP 0009 00 Operator Preventive Maintenance Checks and Services (PMCS).	0009 00-1
WP 0010 00 A/C Air Filter Replacement.	0010 00-1
CHAPTER 4 A/C TROUBLESHOOTING PROCEDURES	
WP 0011 00 A/C Troubleshooting Introduction	0011 00-1
WP 0012 00 A/C Troubleshooting Symptom Index	0012 00-1
WP 0013 00 A/C Troubleshooting Procedures	0013 00-1
CHAPTER 5 UNIT AND DIRECT SUPPORT MAINTENANCE INSTRUCTIONS	
WP 0014 00 General Maintenance Instructions.	0014 00-1
WP 0015 00 A/C System Maintenance	0015 00-1
WP 0016 00 Compressor Replacement	0016 00-1
WP 0017 00 Evaporator Assembly Maintenance.	0017 00-1
WP 0018 00 Condenser Replacement	0018 00-1
WP 0019 00 Receiver/Dryer Replacement.	0019 00-1
WP 0020 00 A/C Hose Replacement	0020 00-1
WP 0021 00 A/C Wiring Harness Replacement	0021 00-1
CHAPTER 6 SUPPORTING INFORMATION	
WP 0022 00 References	0022 00-1
WP 0023 00 Maintenance Allocation Chart (MAC) Introduction	0023 00-1
WP 0024 00 Maintenance Allocation Chart (MAC)	0024 00-1
WP 0025 00 Expendable and Durable Items List	0025 00-1
WP 0026 00 Torque Limits	0026 00-1
WP 0027 00 A/C Kit Installation Instructions	0027 00-1
WP 0028 00 Repair Parts and Special Tools List (RPSTL) Introduction	0028 00-1
WP 0029 00 Repair Parts and Special Tools List (RPSTL)	0029 00-1

Table of Contents - Continued

	Page Number
GROUP 33 SPECIAL PURPOSE KITS	
3307 - SPECIAL PURPOSE KITS.....	1-1
A/C EVAPORATOR ASSEMBLY AND MOUNTING HARDWARE	1 1-1
A/C CONDENSER ASSEMBLY.....	2 2-1
A/C HOSES, COMPRESSOR, AND RECEIVER/DRYER.....	3 3-1
A/C WIRING HARNESES AND PANEL SWITCH.....	4 4-1
GROUP 95 GENERAL USE STANDARDIZED PARTS	
9501- HARDWARE SUPPLIES AND BULK MATERIEL, COMMON.....	BULK-1
BULK.....	BULK BULK-1
NATIONAL STOCK NUMBER INDEX.....	I-1
PART NUMBER INDEX.....	I-2
Index	Index-1

HOW TO USE THIS TECHNICAL BULLETIN

NOTE

If at any time you are unsure how to use this bulletin or you cannot locate the information you need, notify your supervisor.

INTRODUCTION

1. This bulletin is designed to help you operate, maintain, and install the Air Conditioning Kit for the M915P1, M915A1P1, M916P1, M917P1, and M920P1. It also provides installation instructions and the *Repair Parts and Special Tools List (RPSTL)* for the Air Conditioning Kit.
2. This bulletin is written in work package format:
 - a. Chapters divide the bulletin into major categories of information (e.g., *General Information, Equipment Description and Data, and Theory of Operation, Operator Instructions, Operator Maintenance Instructions, A/C Troubleshooting Procedures, Unit and Direct Support Maintenance Instructions, and Supporting Information*).
 - b. Each chapter is divided into work packages, which are identified by a 6-digit number (e.g., 0001 00, 0002 00) located in the upper right-hand corner of each page. The work package page number (e.g., 0001 00-1, 0001 00-2) is located centered at the bottom of each page.
 - c. If a Change Package is issued to this bulletin, added work packages use the 5th and 6th digits of their number to indicate new material. For instance, work packages inserted between WP 0001 00 and WP 0002 00 are numbered WP 0001 01, WP 0001 02, etc.
3. Read through this bulletin to become familiar with its organization and contents before attempting to operate or maintain the Air Conditioning Kit.

CONTENTS OF THIS BULLETIN

1. *Warning Summary*. Located at the beginning of this bulletin. Become familiar with these warnings before operating or performing maintenance on the Air Conditioning Kit.
2. *Table of Contents*. Located in the front of the bulletin, lists all chapters and work packages in the technical bulletin.
 - a. The *Table of Contents* also provides *Reporting Errors and Recommending Improvements* information and DA Form 2028 addresses, for the submittal of corrections to this bulletin.
 - b. If you cannot find what you are looking for in the *Table of Contents*, refer to the alphabetical *Index* at the back of the bulletin.
3. Chapter 1, *General Information, Equipment Description and Data, and Theory of Operation*. This chapter includes *General Information, Equipment Description and Data, and Theory of Operation*. Provides general information on the bulletin and the Air Conditioning Kit.
4. Chapter 2, *Operator Instructions*. Explains and illustrates all operator procedures for the Air Conditioning Kit. *Description and Use of Operator Controls, Operation Under Usual Conditions, Operation Under Unusual Conditions, and Decal and Data Plate Guide*.
5. Chapter 3, *Operator Maintenance Instructions*. This chapter includes *Operator Preventive Maintenance Checks and Services (PMCS) Introduction, Operator Preventive Maintenance Checks and Services (PMCS), and A/C Air Filter Replacement*.
6. Chapter 4, *A/C Troubleshooting Procedures*. This chapter includes *A/C Troubleshooting Introduction, A/C Troubleshooting Symptom Index, and A/C Troubleshooting Procedures*. Provides information for diagnosing and correcting malfunctions in the A/C system.
7. Chapter 5, *Unit and Direct Support Maintenance Instructions*. This chapter includes all maintenance tasks.

CONTENTS OF THIS BULLETIN - CONTINUED

8. Chapter 6, *Supporting Information: References, Maintenance Allocation Chart (MAC) Introduction, Maintenance Allocation Chart (MAC), Expendable and Durable Items List, Torque Limits, A/C Kit Installation Instructions, Repair Parts and Special Tools List (RPSTL) Introduction, and Repair Parts and Special Tools List (RPSTL)*.

FEATURES OF THIS BULLETIN

1. WARNINGS, CAUTIONS, NOTES, subject headings, and other important information are highlighted in **BOLD** print as a visual aid.

WARNING

A WARNING indicates a hazard which may cause injury or death to personnel.

CAUTION

A CAUTION is a reminder of safety practices or directs attention to usage practices that may cause damage to equipment.

NOTE

A NOTE is a statement containing information that will make the procedures easier to perform.

2. Statements and words of particular interest may be printed in CAPITAL LETTERS to create emphasis.
3. Within a procedural step, reference may be made to another work package in this bulletin or to another publication. These references indicate where you should look for more complete information.
 - a. If you are told: “Refer to *Air Conditioning Kit Installation Instructions (WP 0027 00)*”, go to WP 0027 00 in this bulletin for instructions on this procedure.
 - b. If you are told: “For complete information on M915 Operator PMCS, refer to TM 9-2320-273-10”, go to *References* in WP 0022 00 for complete information on the cited reference.
4. Illustrations are placed after, and as close to, the procedural steps to which they apply. Callouts placed on the art are text or numbers.
5. Numbers located at lower right corner of art (e.g., 437-001; 437-002, etc.) are art control numbers and are used for tracking purposes only.
6. Technical instructions include metric units as well as standard units. For your reference, a *Metric Conversion Chart* is located on the inside back cover of the bulletin.

CHAPTER 1
GENERAL INFORMATION, EQUIPMENT
DESCRIPTION AND DATA, AND THEORY OF OPERATION

GENERAL INFORMATION

0001 00

SCOPE

This technical bulletin is for your use in operating and performing Operator, Unit, and Direct Support Maintenance on the Air Conditioning Kit installed on:

Truck, Tractor, Line Haul, 6x4, M915P1

Truck, Tractor, Line Haul, 6x4, M915A1P1

Truck, Tractor, Light Equipment Transporter, 6x6 Winch, M916P1

Truck Chassis, 8x6, for 20 Ton Dump Truck, M917P1

Truck, Tractor, Medium Equipment Transporter, 8x6, with Winch, M920P1

This technical bulletin also covers *Installation Instructions* and *Repair Parts and Special Tools List (RPSTL)* for the Air Conditioning Kit.

MAINTENANCE FORMS, RECORDS, AND REPORTS

Department of the Army forms and procedures used for the equipment will be those prescribed by DA PAM 750-8, *Functional Users Manual for the Army Maintenance Management System (TAMMS)*, as contained in the Maintenance Management Update.

REPORTING EQUIPMENT IMPROVEMENT RECOMMENDATION (EIR)

If your Air Conditioning Kit needs improvement, let us know. Send us an EIR. You, the user, are the only one who can tell us what you do not like about your equipment. Let us know why you do not like the design or performance. If you have Internet access, the easiest and fastest way to report problems or suggestions is to go to <https://aeps.ria.army.mil/aepspublic.cfm> (scroll down and choose the "Submit Quality Deficiency Report" bar). The Internet form lets you choose to submit an Equipment Improvement Recommendation (EIR), or a Product Quality Deficiency Report (PQDR). You may also submit your information using an SF Form 368 (*Product Quality Deficiency Report*). You can send your SF Form 368 via e-mail, regular mail, or facsimile using the addresses/facsimile numbers specified in DA PAM 750-8, *Functional Users Manual for the Army Maintenance Management System (TAMMS)*. We will send you a reply.

CORROSION PREVENTION AND CONTROL (CPC)

1. Corrosion Prevention and Control (CPC) of Army materiel is a continuing concern. It is important that any corrosion problems with this item be reported so the problem can be corrected and improvements can be made to prevent the problem in future items.
2. While corrosion is typically associated with rusting of metals, it can also include deterioration of other materials, such as rubber and plastic. Unusual cracking, softening, swelling, or breaking of these materials may be a corrosion problem. If a corrosion problem is identified, it can be reported using SF Form 368 (*Product Quality Deficiency Report*). Use of key words such as "corrosion," "rust," "deterioration," or "cracking" will ensure the information is identified as a CPC problem. The form should be submitted to the address specified in DA PAM 750-8.

DESTRUCTION OF ARMY MATERIEL TO PREVENT ENEMY USE

For destruction of Army materiel to prevent enemy use, refer to TM 750-244-6.

PREPARATION FOR STORAGE OR SHIPMENT**M915A1P1**

Refer to TM 9-2320-283-20.

M915P1, M916P1, M917P1, AND M920P1

Refer to TM 9-2320-273-20.

LIST OF ABBREVIATION/ACRONYM

NOTE

Refer to ASME Y14.38-1999 for standard abbreviations.

ABBREVIATION/ACRONYM	DEFINITION
A/C	Air Conditioning
C	Celsius
CAGEC	Commercial and Government Entity Code
cm	Centimeter
CPC	Corrosion Prevention and Control
EIR	Equipment Improvement Recommendation
EMI	Electrical Motor Interference
Emp	Electromagnetic Pulse
F	Fahrenheit
ft	Foot
g	Gram
gal	Gallon
HCI	Hardness Critical Item
IAW	In Accordance With
in	Inch
inHg	Inches of Mercury
kg	Kilogram
kPa	Kilopascal
L	Liter
lb	Pound
lb-ft	Pound Foot
lb-in	Pound Inch
m	Meter
MAC	Maintenance Allocation Chart
min	Minutes
mm	Millimeter
N	Newton
Nm	Newton Meter
NSN	National Stock Number
oz	Ounce
PMCS	Preventive Maintenance Checks and Services
PQDR	Product Quality Deficiency Report
psi	Pounds per Square Inch
P/N	Part Number
ROPS	Rollover Protection System
RPM	Revolutions per Minute
RPSTL	Repair Parts and Special Tools List

LIST OF ABBREVIATIONS/ACRONYMS - CONTINUED

ABBREVIATION/ACRONYM	DEFINITION
SMR	Source, Maintenance, and Recoverability
SRA	Specialized Repair Activity
TAMMS	Functional Users Manual for the Army Management System
TMDE	Test, Measurement, and Diagnostic Equipment
Um	Unit of Measure
UOC	Description and Usable on Code
UUT	Unit Under Test
V	Volt
VDC	Volts Direct Current

SAFETY, CARE, AND HANDLING

Follow procedures, warnings, and cautions as written in this technical bulletin.

END OF WORK PACKAGE

EQUIPMENT CHARACTERISTICS, CAPABILITIES, AND FEATURES

1. The Air Conditioning Kit provides the M915P1, M915A1P1, M916P1, M917P1, and M920P1 with cooling of the vehicle cab.
2. The Air Conditioning Kit consists of the following components:
 - a. Compressor
 - b. Condenser
 - c. Evaporator assembly
 - d. Hoses and electrical harness
 - e. Receiver/dryer
 - f. Switch box

LOCATION AND DESCRIPTION OF MAJOR COMPONENTS

The illustration below shows major Air Conditioning Kit components and their location in relation to the cab.

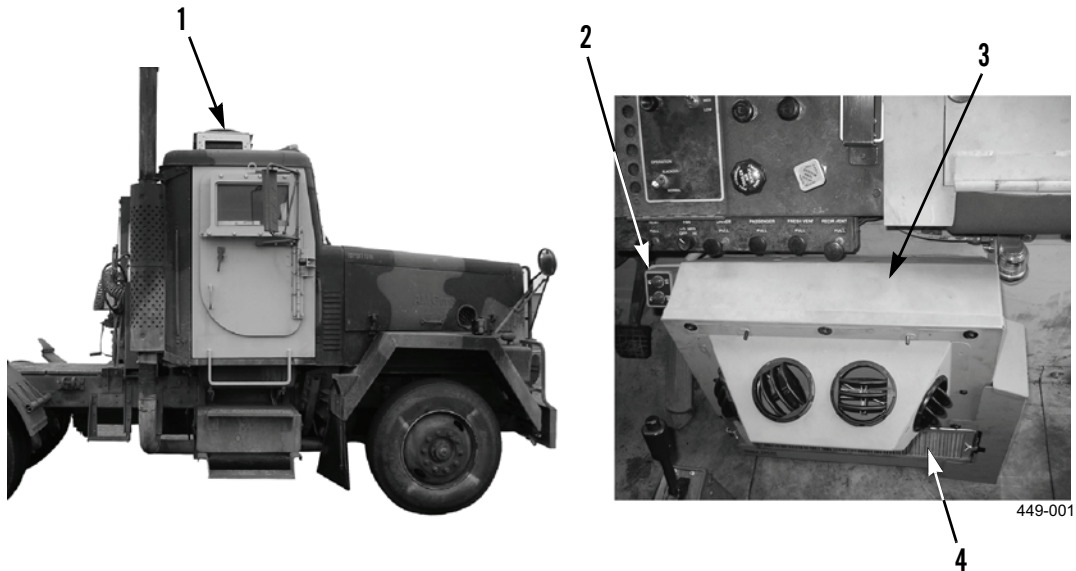

KEY	COMPONENT
1	Condenser
2	Switch Box
3	Evaporator Assembly
4	A/C Filter

LOCATION AND DESCRIPTION OF MAJOR COMPONENTS - CONTINUED

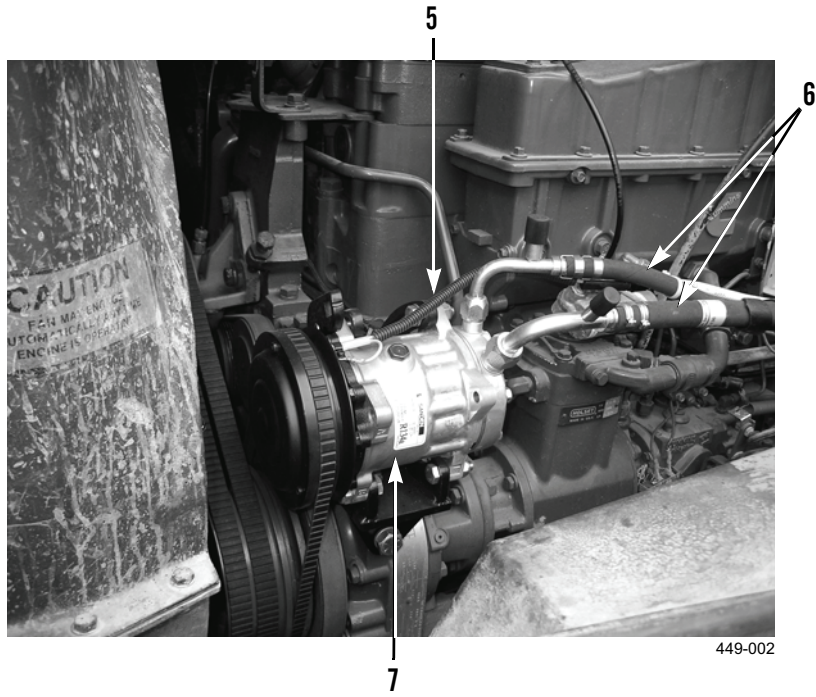

KEY	COMPONENT
5	A/C Electrical Harness
6	A/C Hoses
7	Compressor

LOCATION AND DESCRIPTION OF MAJOR COMPONENTS - CONTINUED

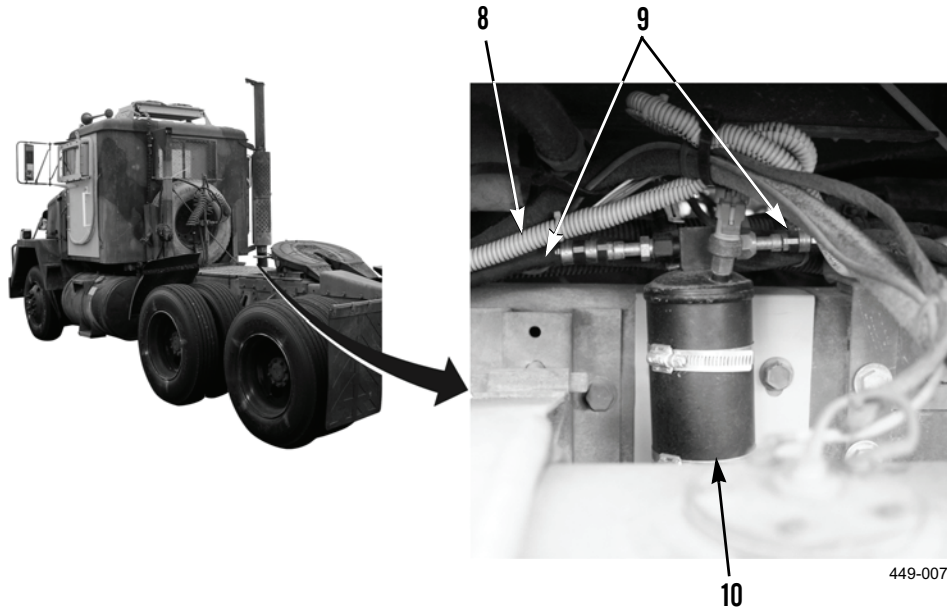

KEY	COMPONENT
8	A/C Electrical Harness
9	A/C Hoses
10	Receiver/Dryer

EQUIPMENT DATA

A/C SYSTEM

The floor mounted A/C system includes an evaporator assembly, condenser, receiver/dryer, hoses, and wiring harnesses. This system operates from a compressor mounted on the side of the engine. It is a R-134a system that holds 4.0 lb of refrigerant. A separate set of controls is provided for this added A/C system (WP 0004 00).

Refer to *A/C System Maintenance* (WP 0015 00) for evacuating and recharging information. Refer to *A/C Troubleshooting Symptom Index* (WP 0012 00) for troubleshooting information.

END OF WORK PACKAGE

THEORY OF OPERATION

0003 00**GENERAL**

1. The Air Conditioning Kit for the M915P1, M915A1P1, M916P1, M917P1, and M920P1 consists of the following, as illustrated and described in the *RPSTL* (WP 0029 00):
2. The Air Conditioning Kit consists of the following components:
 - a. Compressor
 - b. Condenser
 - c. Evaporator assembly
 - d. Hoses and electrical harness
 - e. Receiver/dryer
 - f. Switch box
3. This Air Conditioning Kit is installed on an armored vehicle to control the temperature inside the cab. A belt-driven compressor is installed on the engine, a condenser is installed on the cab roof, an evaporator assembly is installed on the interior of the cab, and a receiver/dryer is installed on the outside of the cab. Refrigerant is transferred to each of these components through O-ring sealed hoses. Electrical power is tied into the existing electrical system on the vehicle. The entire system is controlled by an A/C ON/OFF switch and fan speed LOW/MEDIUM/HI switch inside the cab.

END OF WORK PACKAGE

CHAPTER 2
OPERATOR INSTRUCTIONS

DESCRIPTION AND USE OF OPERATOR CONTROLS

0004 00

GENERAL

1. This work package describes all operator controls for the Air Conditioning Kit.
2. Use the following information to operate the Air Conditioning Kit controls.

AIR CONDITIONING KIT CONTROLS

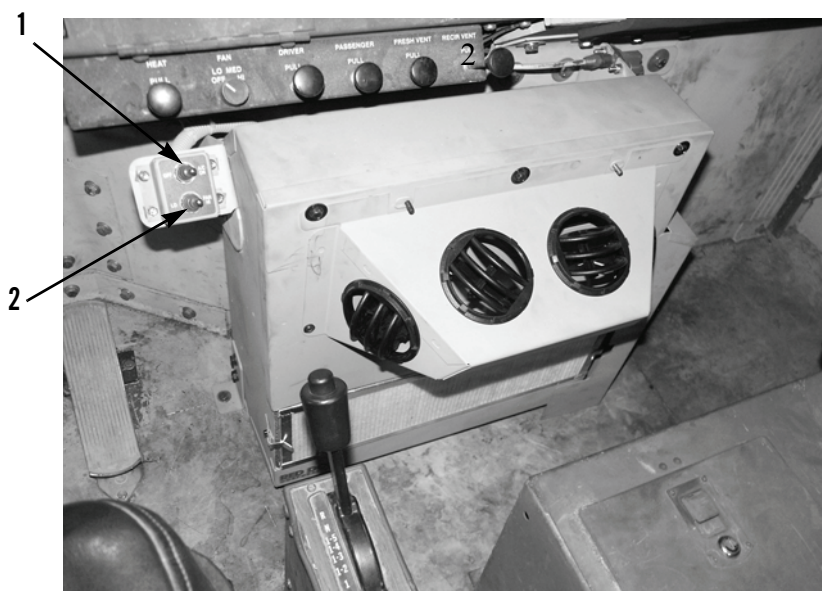

449-003

Key	Control or Indicator	Function
1	A/C ON/OFF Switch	Provides power ON and OFF control for the A/C unit.
2	A/C Fan Speed Switch	Controls the fan speed for the A/C unit. Move switch to left position for LOW, center position for MEDIUM, and right position for HIGH speed.

END OF WORK PACKAGE

OPERATION UNDER USUAL CONDITIONS

0005 00**GENERAL**

1. This work package contains instructions for safely operating the Air Conditioning Kit on armored M915P1, M915A1P1, M916P1, M917P1, and M920P1 vehicles.
2. Read and follow the procedures in *Operation Under Usual Conditions* in TM 9-2320-283-10 for the M915A1P1 or *Operation Under Usual Conditions* in TM 9-2320-273-20 for M915P1, M916P1, M917P1, and M920P1 before operating Air Conditioning Kit.

INITIAL ADJUSTMENTS AND DAILY CHECKS**NOTE**

Refer to WP 0004 00 for the location and operation of operator controls.

Perform *Before operation Preventive Maintenance Checks and Services (PMCS)* before operating Air Conditioning Kit (WP 0008 00 and WP 0009 00).

OPERATING AIR CONDITIONING KIT

1. Start engine and allow engine to reach operating temperature (TM 9-2320-283-10 for the M915A1P1 or TM 9-2320-273-10 for M915P1, M916P1, M917P1, and M920P1).
2. Move A/C ON/OFF switch to ON position (WP 0004 00).
3. Adjust fan speed switch as necessary (WP 0004 00).

END OF WORK PACKAGE

OPERATION UNDER UNUSUAL CONDITIONS

0006 00

Read and follow the procedures in *Operation Under Unusual Conditions* in TM 9-2320-283-10 for the M915A1P1 or *Operation Under Unusual Conditions* in TM 9-2320-273-10 for M915P1, M916P1, M917P1, and M920P1 before operating Air Conditioning Kit.

OPERATION IN EXTREME TEMPERATURES

Operation in extreme temperatures with armor installed requires altering operating procedures.

Extreme Cold

NOTE

Clearing frost from ballistic glass requires more time than standard glass.

1. Extend vehicle warm up time and operate heater/defroster to clear frost from ballistic glass (TB 9-2320-273-13&P-1).
2. It will require more effort to open and close door, egress window, and access door.

Extreme Heat

NOTE

The armored cab absorbs and retains more heat than a standard cab.

1. Park vehicle away from direct sunlight whenever possible.
2. Extended A/C usage is required to cool the interior of cab.
3. Extend vehicle warm up times and operate A/C to cool down interior of cab (WP 0004 00).

END OF WORK PACKAGE

INTRODUCTION

This work package includes illustrations showing the location of decals and data plates specific to the Air Conditioning Kit. For stowage and decal/data plate guide specific to the M915A1P1, refer to TM 9-2320-283-10. For the M915P1, M916P1, M917P1 and M920P1, refer to TM 9-2320-273-10.

DECALS AND DATA PLATES

There are no decals or data plates specific to the Air Conditioning Kit.

END OF WORK PACKAGE

CHAPTER 3
OPERATOR MAINTENANCE INSTRUCTIONS

GENERAL**NOTE**

- Information in this PMCS Introduction applies only to preventive maintenance checks and services (PMCS) for the Air Conditioning Kit.
 - For information specific to the M915P1, M915A1P1, M916P1, M917P1, and M920P1, refer to *PMCS Introduction* in TB 9-2320-273-13&P-1.
1. To ensure the Air Conditioning Kit is ready for operation at all times, it must be inspected on a regular basis so defects may be found and corrected before they result in injury or death due to equipment failure.
 2. The *PMCS Table* in WP 0009 00 contains systematic instructions for inspections and services to keep equipment in good operating condition and ready for its primary mission.

EXPLANATION OF TABLE ENTRIES

1. **Item Number (Item No.) Column.** Numbers in this column are for reference. When completing DA Form 2404 or DA Form 5988-E (*Equipment Inspection and Maintenance Worksheet*), include the item number for the check/service indicating a fault. Item numbers also appear in the order in which you must perform checks and services for the interval listed.
2. **Interval Column.** This column tells you when you must perform the procedure in the *Procedure* column.
 - a. *Before* procedures must be done immediately before you operate vehicle with Air Conditioning Kit installed.
 - b. *After* procedures must be done immediately after operating vehicle with Air Conditioning Kit installed.
 - c. *Weekly* procedures must be done once each week.
3. **Location, Item to Check/Service Column.** This column provides the location and item to be checked or serviced.

NOTE

The WARNINGS and CAUTIONS appearing in your PMCS table should always be observed. WARNINGS and CAUTIONS appear before applicable procedures. You must observe these WARNINGS to prevent injury or death to personnel, and CAUTIONS to prevent your equipment from being damaged.

4. **Procedure Column.** This column includes the procedure you must perform to know if the equipment is ready or available for its intended mission. You must perform the procedure at the time stated in the Interval column.
5. **Not Fully Mission Capable If: Column.** Information in this column tells you what faults will keep your equipment from being capable of performing its primary mission. If you perform check/service procedures that show faults listed in this column, the equipment is not mission-capable. Follow standard operating procedures for maintaining the equipment or reporting equipment failure.

GENERAL PMCS PROCEDURES

1. Always perform PMCS in the same order. With experience, you should be able to identify problems easily.
2. If anything looks wrong and you cannot fix it, write it on your DA Form 2404 or DA Form 5988-E. If you find something seriously wrong, IMMEDIATELY report it to your Supervisor.
3. Before performing preventive maintenance, read all the checks required for the applicable interval and prepare everything needed to make all the checks. For example, you will always need a Rag, Wiping (Item 9, WP 0025 00) or two.

**OPERATOR PREVENTIVE MAINTENANCE CHECKS AND SERVICES (PMCS)
INTRODUCTION - CONTINUED**

0008 00

GENERAL PMCS PROCEDURES - CONTINUED**WARNING**

- Solvent cleaning compound MIL-PRF-680 Type II and III may be irritating to the eyes and skin. Use protective gloves and goggles. Use in well-ventilated areas. Use respirator as needed. Accidental ingestion can cause irritation of digestive tract and respiratory tract, may cause lung and central nervous system damage. Can be fatal if swallowed. Inhalation of high/massive concentrations can cause coma or be fatal. First aid for ingestion: do not induce vomiting. Seek immediate medical attention. First aid for skin contact: remove contaminated clothing. Wash skin thoroughly with soap and water. If symptoms persist, seek medical attention. First aid for eye contact: flush with water for 15 minutes or until irritation subsides. If symptoms persist, seek medical attention. First aid for inhalation: move to fresh air. If not breathing, provide artificial respiration. If symptoms persist, seek medical attention. Keep away from open flames and other sources of ignition.
 - The flashpoint for type II solvent cleaning compound is 141-198°F (61-92°C) and type III is 200-241°F (93-116°C).
 - Improper cleaning methods and use of unauthorized cleaning solvents may injure personnel and damage equipment.
 - Fire extinguishers should be placed nearby when using solvent cleaning compound.
 - Cloths or rags saturated with solvent cleaning compound must be disposed of IAW authorized facilities' procedures.
 - Eye shields must be worn when cleaning with a wire brush. Flying rust and metal particle may cause injury.
 - Failure to follow these warnings may result in injury or death to personnel.
- a. **Keep It Clean.** Dirt, grease, oil, and debris get in the way and may cover up a serious problem. Clean as you work and as needed. Use Cleaning Compound, Solvent, Type III (Item 2, WP 0025 00) on all metal surfaces. Use Detergent, General Purpose, Liquid (Item 5, WP 0025 00) and water when you clean rubber, plastic, and painted surfaces.

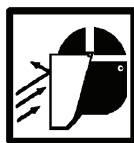
**WARNING**

- Contact with refrigerant can cause frostbite. Keep hands and face away to prevent personal injury.
- Protective face shield must always be worn when refrigerant lines are opened, even if the gauges indicate the system is empty.
- Always use caution if a fitting is removed. Slowly loosen the fitting. If the system is still under any pressure, release it slowly in a well-ventilated area.
- DO NOT smoke when servicing A/C or wherever refrigerant gas may be present.
- Failure to follow these warnings may result in injury or death to personnel.

OPERATOR PREVENTIVE MAINTENANCE CHECKS AND SERVICES (PMCS)
INTRODUCTION - CONTINUED0008 00

GENERAL PMCS PROCEDURES - CONTINUED

- b. **A/C Hoses and Fittings.** Inspect A/C hoses and fittings for any signs of leakage. Leaks can be identified by oily residue on or near fittings and hoses.
- c. **A/C Evaporator and Condenser.** Inspect condenser and evaporator cores for damaged vanes or any signs of leakage. Leaks can be identified by oily residue on the evaporator core or condenser core.

WARNING

When servicing this vehicle, performing maintenance, or disposing of materials such as engine coolant, hydraulic fluid, lubricants, battery acids or batteries, and CARC paint, consult your unit/local hazardous waste disposal center or safety office for local regulatory guidance. If further information is needed, please contact The Army Environmental Hotline at 1-800-872-3845.

- d. **Hazardous Waste Disposal.** Ensure all spills are cleaned up and disposed of IAW local policy and ordinances.
- e. **Rust and Corrosion.** Check metal parts for rust and corrosion. If any bare metal or corrosion exists, clean and apply a light coat of clean Oil, Lubricating, OE/HDO-10 (Item 7, WP 0025 00). Report it to your supervisor.
- f. **Bolts, Nuts, and Screws.** Check bolts, nuts, and screws for obvious loose, missing, bent, or broken condition. If you find loose or missing components, notify your supervisor.
- g. **Electric Wires and Connectors.** Look for cracked or broken insulation, bare wires, and loose or broken connectors. Reconnect loose connectors. Ensure that wires are in good condition.

END OF WORK PACKAGE

Table 1. Operator Preventive Maintenance Checks and Services (PMCS).

Item No.	Interval	Location	Procedure	Not Fully Mission Capable If:
		Item To Check/ Service		
			<p>NOTE</p> <ul style="list-style-type: none"> • Perform PMCS for the Crew Protection Kit (TB 9-2320-273-13&P-1) BEFORE performing PMCS for the Air Conditioning Kit. • Review all WARNINGS, CAUTIONS, and NOTES before performing PMCS and operating the air conditioning. • Perform all PMCS checks if: <ul style="list-style-type: none"> a. You are the assigned operator but have not operated the vehicle with air conditioning since the last weekly checks. b. You are operating the vehicle with air conditioning for the first time. • Perform PMCS with vehicle stopped on level ground, parking brake applied, transmission in N (Neutral), wheels chocked, and engine shut down. 	

Table 1. Operator Preventive Maintenance Checks and Services (PMCS) - Continued.

Item No.	Interval	Location	Procedure	Not Fully Mission Capable If:
		Item To Check/Service		
1	During	Operation	a. Start engine (for M915A1P1, refer to TM 9-2320-283-10. For M915P1, M916P1, M917P1, and M920P1, refer to TM 9-2320-273-10). b. Turn A/C system ON and fan speed switch to HIGH position (WP 0004 00). c. Operate A/C system for five minutes and check temperature of air coming out of blower unit vents.	Temperature of air coming out of vents is not cold and A/C is required for mission.
		Blower Unit		

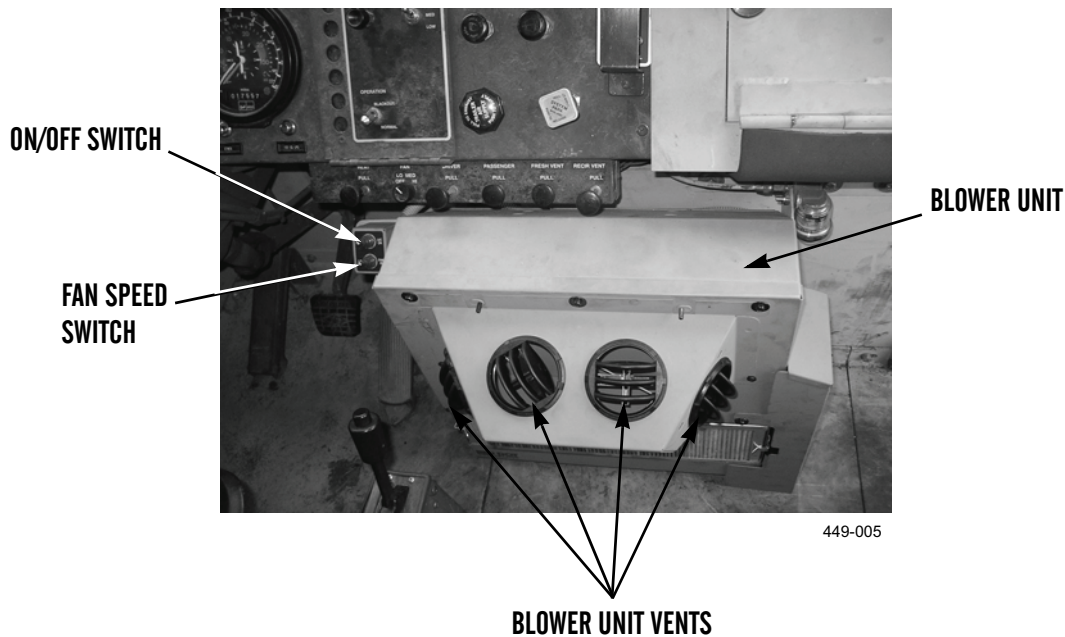

Table 1. Operator Preventive Maintenance Checks and Services (PMCS) - Continued.

Item No.	Interval	Location	Procedure	Not Fully Mission Capable If:
		Item To Check/Service		
2	Weekly	Roof		
		Condenser	<p>a. Inspect condenser for damage and loose or missing mounting hardware.</p> <p>b. Inspect condenser for leaks. Leaks can be identified by oil residue on fittings or on condenser core.</p> <p>c. Inspect A/C hoses and electrical harness for damage and loose or missing mounting hardware.</p> <p>d. Inspect A/C hoses for leaks. Leaks can be identified by oil residue on fittings or along hose.</p>	<p>Condenser is damaged or mounting bolts are loose or missing and A/C is required for mission.</p> <p>Leaks are evident and A/C is required for mission.</p> <p>A/C hoses or electrical harness are damaged or have loose or missing mounting hardware and A/C is required for mission.</p> <p>Leaks are evident and A/C is required for mission.</p>

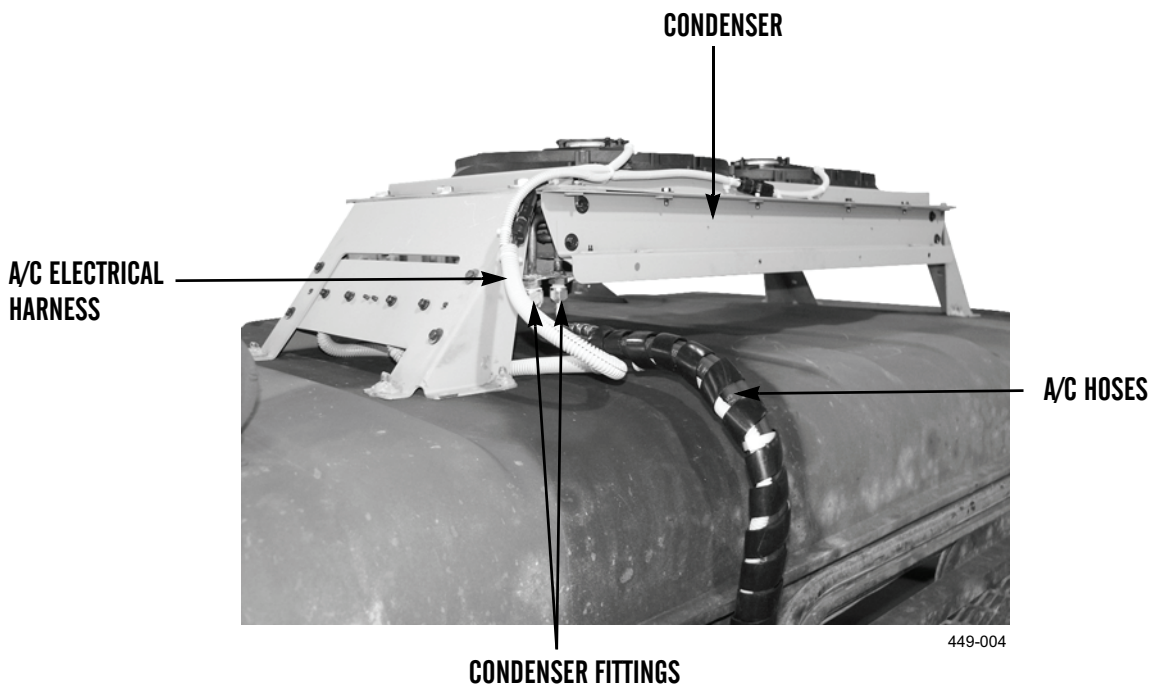

Table 1. Operator Preventive Maintenance Checks and Services (PMCS) - Continued.

Item No.	Interval	Location	Procedure	Not Fully Mission Capable If:
		Item To Check/ Service		
3	Weekly	Interior of Cab	a. Inspect evaporator assembly for damage and loose or missing mounting hardware. b. Inspect switch box for damage and loose or missing mounting hardware.	Evaporator assembly unit is damaged or has loose or missing mounting hardware and A/C is required for mission. Switch box is damaged or has loose or missing mounting hardware and A/C is required for mission.
		Evaporator Assembly		

Table 1. Operator Preventive Maintenance Checks and Services (PMCS) - Continued.

Item No.	Interval	Location	Procedure	Not Fully Mission Capable If:
		Item To Check/Service		
3 (Con't)	Weekly	Evaporator Assembly		

A black and white photograph of an evaporator assembly. The unit is rectangular with two circular air vents on the front. Above the unit is a control panel with several knobs and switches. Labels with arrows point to various components: 'SWITCH BOX' points to a control knob on the left; 'EVAPORATOR ASSEMBLY' points to the top surface of the unit; 'A/C FILTER ELEMENT' points to a rectangular filter on the right side; and 'DRAIN TUBES (LOCATED UNDER UNIT)' points to the bottom of the unit. The number '449-005' is printed in the bottom right corner of the photo.

Table 1. Operator Preventive Maintenance Checks and Services (PMCS) - Continued.

Item No.	Interval	Location	Procedure	Not Fully Mission Capable If:
		Item To Check/ Service		
4	Weekly	Outside of Cab Left Side		
		Receiver/Dryer Unit	<p>a. Inspect receiver/dryer unit for damage and loose or missing mounting hardware.</p> <p>b. Inspect receiver/dryer unit for leaks. Leaks can be identified by oil residue on fittings.</p> <p>c. Inspect A/C hoses and electrical harness for damage and loose or missing mounting hardware.</p> <p>d. Inspect A/C hoses for leaks. Leaks can be identified by oil residue on fittings or along hose.</p>	<p>Receiver/dryer unit is damaged or has loose or missing mounting hardware and A/C is required for mission.</p> <p>Leaks are evident and A/C is required for mission.</p> <p>A/C hoses or electrical harness are damaged or have loose or missing mounting hardware and A/C is required for mission.</p> <p>Leaks are evident and A/C is required for mission.</p>

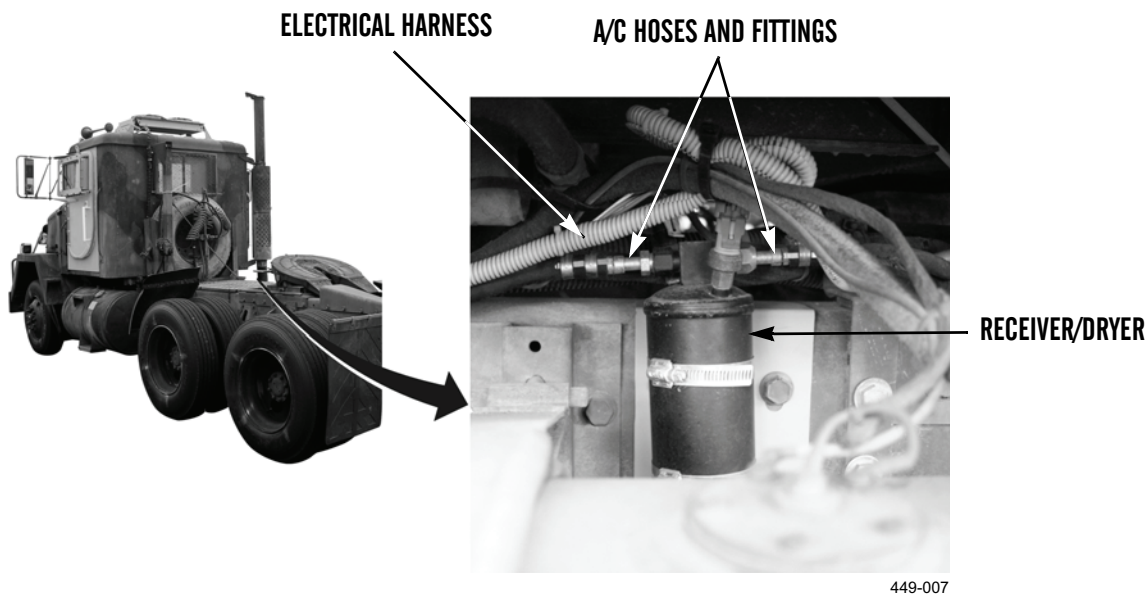

Table 1. Operator Preventive Maintenance Checks and Services (PMCS) - Continued.

Item No.	Interval	Location	Procedure	Not Fully Mission Capable If:
		Item To Check/ Service		
5	Weekly	Engine Compartment	a. Open left-side engine cover (for M915A1P1, refer to TM 9-2320-283-10. For M915P1, M916P1, M917P1, and M920P1, refer to TM 9-2320-273-10). b. Inspect compressor for damage and loose or missing mounting hardware. c. Inspect compressor for leaks. Leaks can be identified by oil residue on fittings. d. Inspect A/C hoses and electrical harness for damage and loose or missing mounting hardware. e. Inspect A/C hoses for leaks. Leaks can be identified by oil residue on fittings or along hose. f. Inspect compressor belt for damage and correct tightness (120 lb for new belts).	Compressor is damaged or mounting bolts are loose or missing and A/C is required for mission. Leaks are evident and A/C is required for mission. A/C hoses or electrical harness are damaged or have loose or missing mounting hardware and A/C is required for mission. Leaks are evident and A/C is required for mission. Compressor belt is damaged or loose and A/C is required for mission.
		Compressor		

Table 1. Operator Preventive Maintenance Checks and Services (PMCS) - Continued.

Item No.	Interval	Location	Procedure	Not Fully Mission Capable If:
		Item To Check/Service		
5 (Con't)		Compressor		
<p style="text-align: right; margin-right: 50px;">449-002</p>				

END OF WORK PACKAGE

A/C AIR FILTER REPLACEMENT

0010 00

THIS WORK PACKAGE COVERS

Removal, Cleaning and Inspection, Installation

INITIAL SETUP

Maintenance Level

Operator

Materials/Parts

Rag, Wiping (Item 9, WP 0025 00)

References

WP 0014 00

Equipment Conditions

(M915A1P1)

Vehicle parked on level ground (TM 9-2320-283-10)

Parking/Emergency Brake applied (TM 9-2320-283-10)

Equipment Conditions - Continued

(M915A1P1) - Continued

Engine OFF (TM 9-2320-283-10)

Ignition Key Switch in OFF position (TM 9-2320-283-10)

(M915P1, M916P1, M917P1, and M920P1)

Vehicle parked on level ground (TM 9-2320-273-10)

Parking/Emergency Brake applied (TM 9-2320-273-10)

Engine OFF (TM 9-2320-273-10)

Ignition Key Switch in OFF position (TM 9-2320-273-10)

REMOVAL**WARNING**

- If NBC exposure is suspected, personnel wearing protective equipment should handle all air cleaner media. Consult your NBC Officer or NBC NCO for appropriate handling or disposal procedures.
 - NBC contaminated filters must be handled using adequate precautions and must be disposed of by trained personnel.
 - Wear eye protection when removing filter.
 - Failure to follow these warnings may cause injury or death to personnel.
1. Unlatch two clamps (3) on evaporator assembly (1).
 2. Remove air filter (2) from evaporator assembly (1).

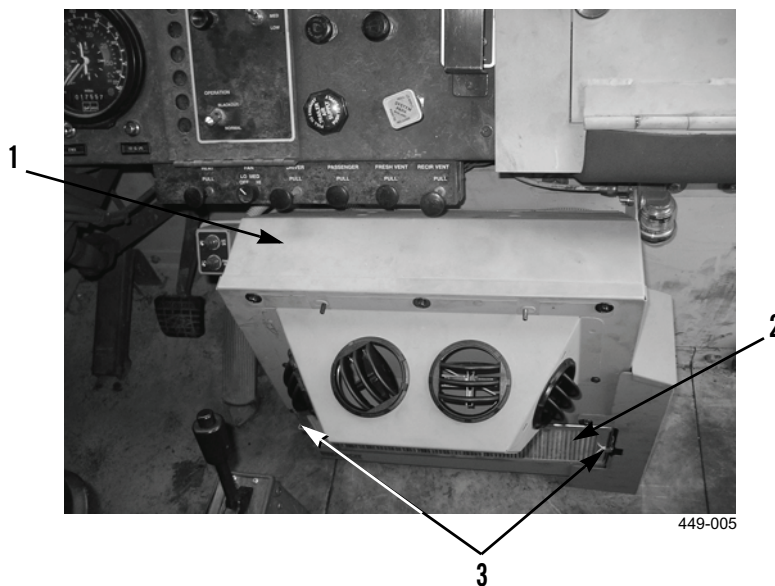
**CLEANING AND INSPECTION**

Clean and inspect all parts IAW *General Maintenance Instructions* (WP 0014 00).

INSTALLATION

1. Install air filter (2) in evaporator assembly (1).
2. Latch two clamps (3) on evaporator assembly (1).

END OF WORK PACKAGE

CHAPTER 4
A/C TROUBLESHOOTING PROCEDURES

GENERAL

1. This chapter provides information for identifying and correcting malfunctions which may develop while operating the A/C system in the armored M915P1, M915A1P1, M916P1, M917P1, and M920P1.
2. The *A/C Troubleshooting Symptom Index* in WP 0012 00 lists common malfunctions which may occur and refers you to the proper page in WP 0013 00 for a troubleshooting procedure.
3. Refer to electrical schematic diagram and component identification at the end of this work package.
4. Before performing troubleshooting, read and follow all safety instructions found in the *Warning Summary* at the front of this bulletin.
5. The *A/C Troubleshooting Symptom Index* (WP 0012 00) cannot list all malfunctions that may occur, nor all tests or inspections and corrective actions. If a malfunction is not listed, or is not corrected by the listed corrective actions, notify your supervisor.
6. When troubleshooting a malfunction:
 - a. Locate the symptom or symptoms in WP 0012 00 that best describe the malfunction.
 - b. Turn to the page in WP 0013 00 where the troubleshooting procedures for the malfunction in question are described. Headings at the top of each page show how each troubleshooting procedure is organized: MALFUNCTION, TEST OR INSPECTION (in step number order), and CORRECTIVE ACTION.
 - c. Perform each step in the order listed until the malfunction is corrected. DO NOT perform any maintenance task unless the troubleshooting procedure tells you to do so.

EXPLANATION OF COLUMNS

The columns in Table 1 in WP 0013 00 are defined as follows:

1. **MALFUNCTION**. A visual or operational indication that something is wrong with the equipment.
2. **TEST OR INSPECTION**. A procedure to isolate the problem in a system or component.
3. **CORRECTIVE ACTION**. A procedure to correct the problem.

COMPONENT IDENTIFICATION

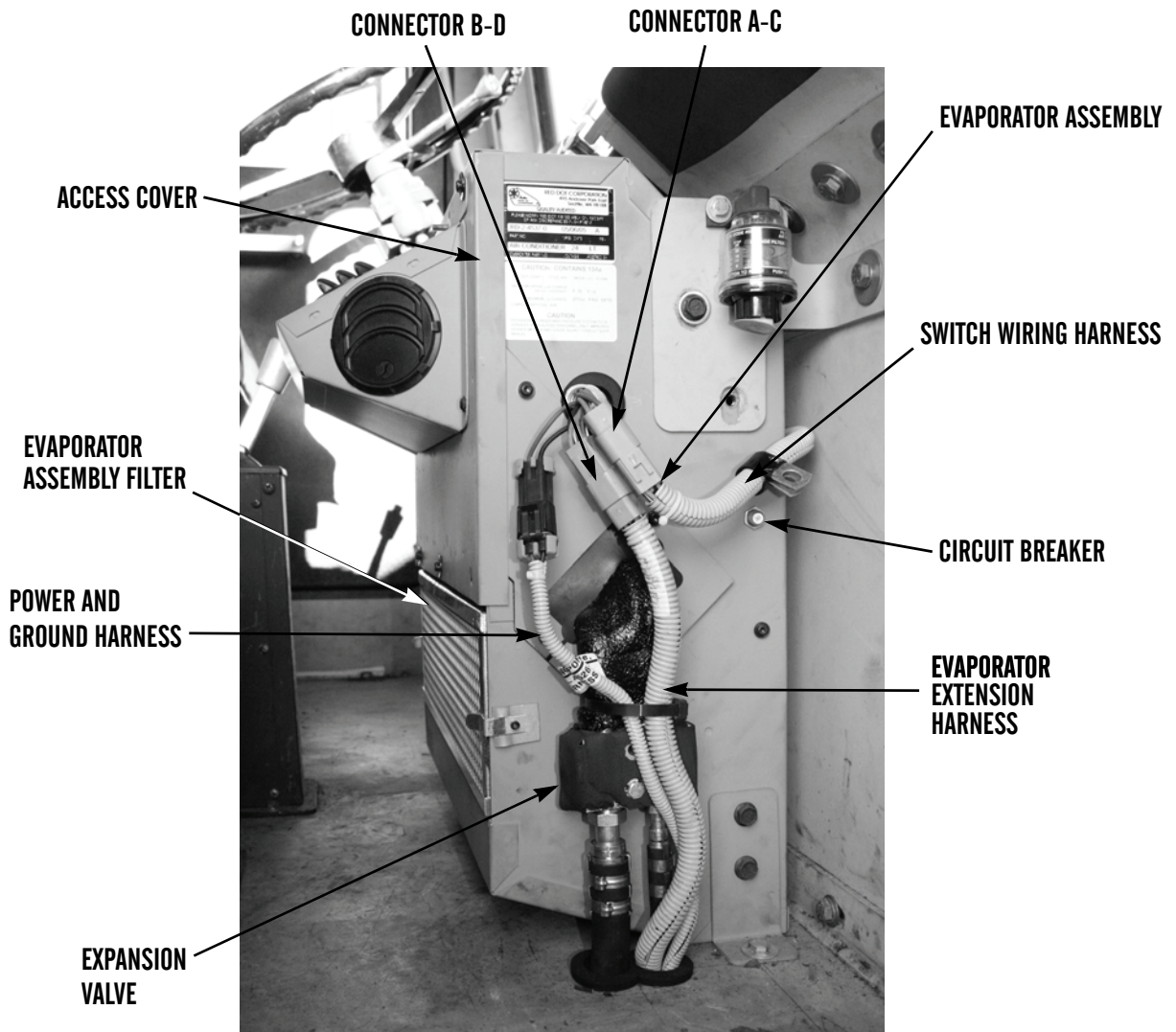

449-006

COMPONENT IDENTIFICATION - CONTINUED

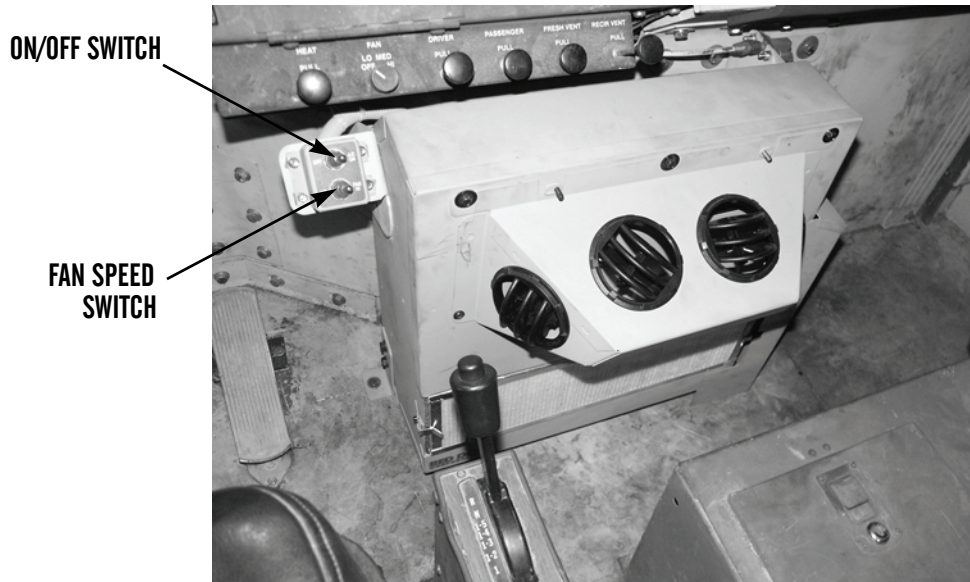

449-003

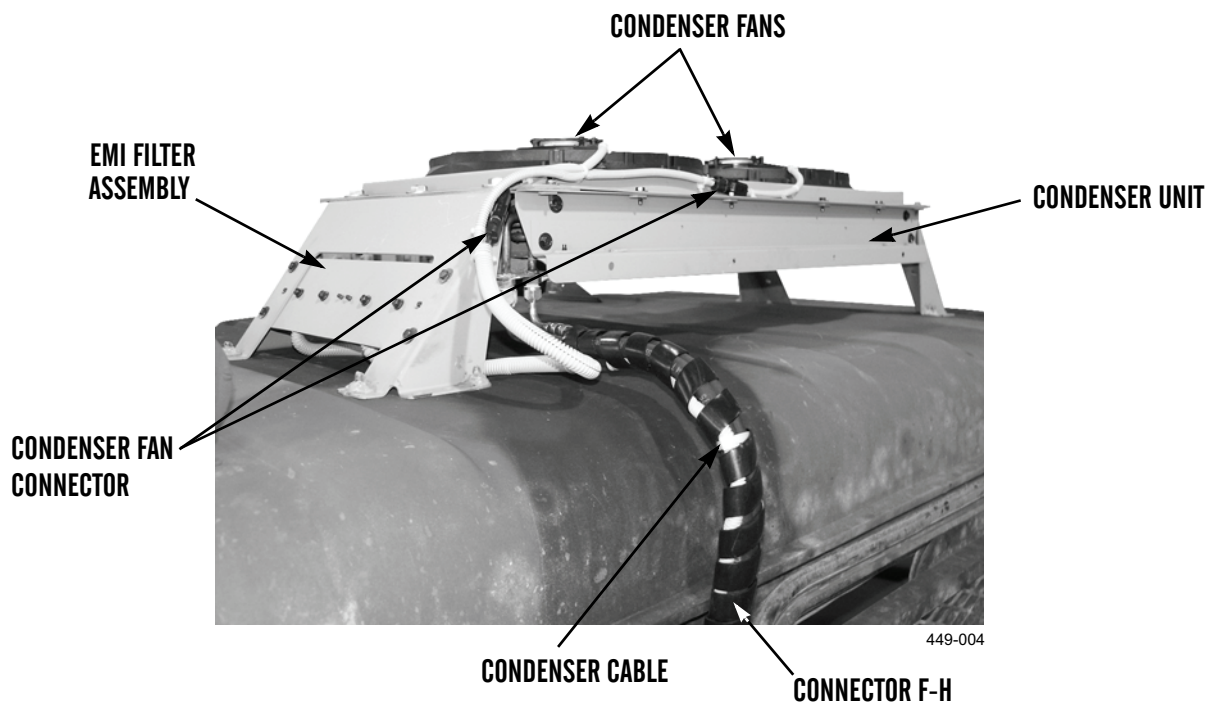

449-004

COMPONENT IDENTIFICATION - CONTINUED

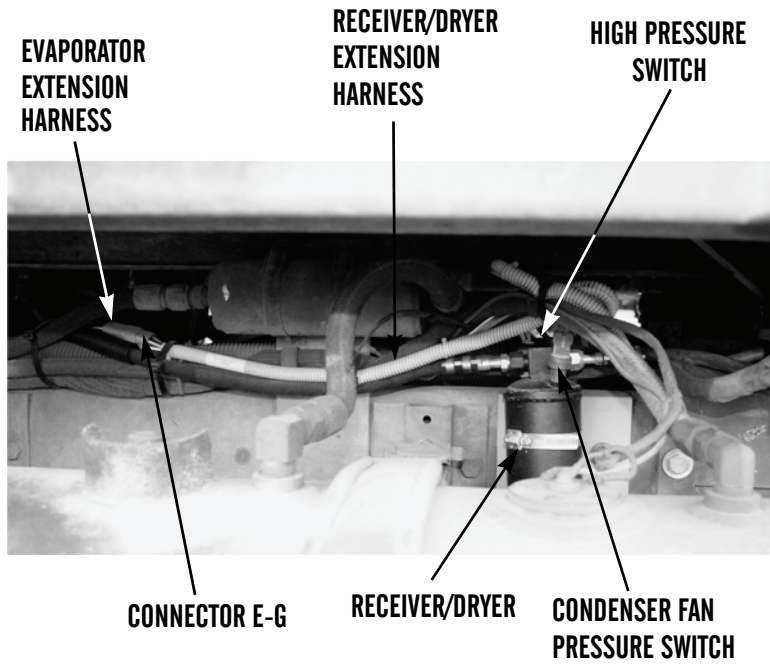

449-016

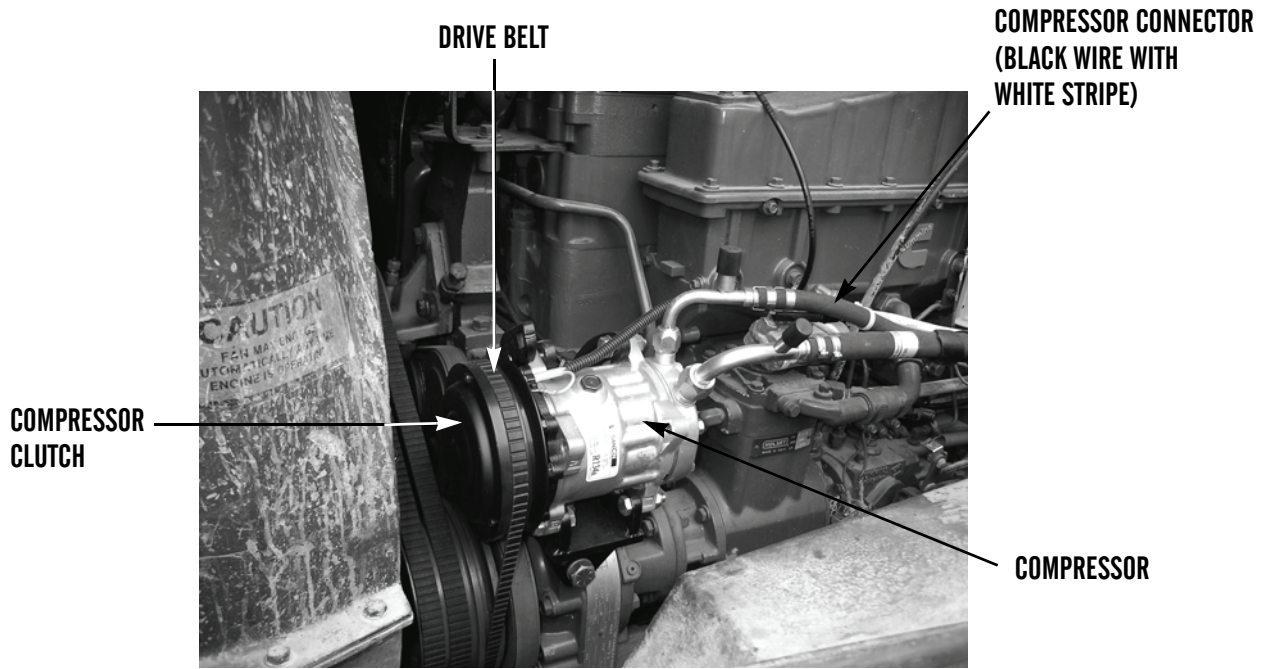

449-002

COMPONENT IDENTIFICATION - CONTINUED



Table 1. High Side/Low Side Gauge Pressure at Ambient Temperature Cross-Reference.

Ambient Temperature °F (°C)	High Side Pressure psi (kPa)	Low Side Pressure psi (kPa)
61°F (16°C)	123 to 174 psi (850 to 1,200 kPa)	3 to 15 psi (20 to 100 kPa)
70°F (21°C)	152 to 254 psi (1,050 to 1,750 kPa)	3 to 15 psi (20 to 100 kPa)
81°F (27°C)	181 to 276 psi (1,250 to 1,900 kPa)	3 to 15 psi (20 to 100 kPa)
90°F (32°C)	203 to 312 psi (1,400 to 2,150 kPa)	4 to 22 psi (30 to 150 kPa)
100°F (38°C)	232 to 334 psi (1,600 to 2,300 kPa)	4 to 29 psi (30 to 200 kPa)
109°F (43°C)	276 to 363 psi (1,900 to 2,500 kPa)	4 to 36 psi (30 to 250 kPa)

END OF WORK PACKAGE

A/C TROUBLESHOOTING SYMPTOM INDEX

0012 00

Malfunction/Symptom **Troubleshooting Procedure Page**

GENERAL TROUBLESHOOTING

- 1. A/C Unit Not Producing Cool Air..... 0013 00-1
- 2. Compressor Noise or Vibration..... 0013 00-1
- 3. Frozen Evaporator Assembly Coil - Reduced Air Flow..... 0013 00-1

A/C ELECTRICAL SYSTEM

- 1. A/C System Does Not Function. 0013 00-2
- 2. A/C System Energized But Evaporator Assembly Does Not Function. 0013 00-6
- 3. Only One Condenser Fan Operates..... 0013 00-12
- 4. Evaporator Assembly Works But Condenser Fan Does Not. 0013 00-14
- 5. Evaporator Assembly Works But Compressor Does Not..... 0013 00-19

A/C SYSTEM PRESSURE DIAGNOSIS

- 1. High Side and Low Side Pressure Normal and Evaporator Assembly Not Producing Cold Air. 0013 00-25
- 2. High Side Pressure Normal to High - Low Side Pressure Normal to High. 0013 00-25
- 3. High Side Pressure Low - Low Side Pressure Low. 0013 00-25
- 4. High Side Pressure Low - Low Side Pressure Zero to Negative - Frost on Tubes from Receiver/Dryer
to Evaporator Assembly 0013 00-25
- 5. High Side Pressure Low - Low Pressure Side High 0013 00-25
- 6. High Side Pressure High - Low Pressure Side Low. 0013 00-25
- 7. High Side Pressure High - Low Pressure Side High - Low Side Lines Hot to Touch. 0013 00-25
- 8. High Side Pressure High - Low Pressure Side High..... 0013 00-25

END OF WORK PACKAGE

MALFUNCTION	TEST OR INSPECTION	CORRECTIVE ACTION
GENERAL TROUBLESHOOTING		
<p>1. A/C Unit Not Producing Cool Air.</p>	<p>1. Inspect evaporator assembly filter (WP 0010 00).</p> <p>2. Check system pressures to ensure all components are operating correctly.</p> <p>3. Check system for leaks (WP 0015 00).</p>	<p>1. Replace filter if obstructed.</p> <p>2. If filter is not obstructed, proceed to next step.</p> <p>Refer to <i>A/C System Pressure Diagnosis</i> in this work package.</p> <p>Repair or replace leaking components and recharge system (WP 0015 00).</p>
<p>2. Compressor Noise or Vibration.</p>	<p>1. Set A/C ON/OFF Switch to the OFF position (WP 0004 00).</p> <p>2. Turn ignition key switch to the OFF position (TM 9-2320-273-10 and TM 9-2320-283-10).</p> <p>3. Check to see that belt tension is correct (120 lb).</p> <p>4. Check to see if compressor is seized.</p> <p style="padding-left: 20px;">(a) Remove belt (WP 0016 00).</p> <p style="padding-left: 20px;">(b) Attempt to rotate compressor.</p> <p>5. Check alignment of pulley.</p> <p>6. Check compressor mounting bolts for tightness.</p> <p>7. Check if refrigerant system is overcharged. System should contain 4.75 lb of refrigerant.</p>	<p>Adjust belt tension (WP 0016 00).</p> <p>Replace compressor (WP 0016 00).</p> <p>Align pulley (WP 0016 00).</p> <p>Tighten compressor mounting bolts (WP 0016 00).</p> <p>1. Recover refrigerant (WP 0015 00).</p> <p>2. Recharge system (WP 0015 00).</p>
<p>3. Frozen Evaporator Assembly Coil - Reduced Air Flow.</p>	<p>1. Troubleshoot compressor and thermostat (refer to <i>A/C Electrical Troubleshooting</i>, Malfunction, step 5).</p> <p>2. Verify A/C system pressures (WP 0015 00).</p> <p>3. Inspect wiring harness inside evaporator assembly for damage. Remove evaporator assembly access cover (WP 0017 00) to access wiring harness.</p> <p>4. Inspect wiring harness for damage.</p>	<p>Replace compressor (WP 0016 00) or thermostat (WP 0017 00).</p> <p>Refer to <i>A/C System Pressure Diagnosis</i> in this work package.</p> <p>1. If damage is found, repair wire or replace wiring harness (WP 0021 00).</p> <p>2. If no damage is found, replace power relay (WP 0017 00).</p>

MALFUNCTION	TEST OR INSPECTION	CORRECTIVE ACTION
<p>1. A/C System Does Not Function.</p>	<p style="text-align: center;">A/C ELECTRICAL SYSTEM</p> <div style="text-align: center;">  <p>WARNING</p> <p>Before removing any component of electrical system, be sure battery disconnect switch is in OFF position. Remove all jewelry before working on electrical system. Failure to follow this warning may cause injury to personnel.</p> </div> <ol style="list-style-type: none"> 1. Verify ON/OFF switch is not in the OFF position (WP 0005 00). 2. Verify circuit breaker (WP 0017 00) on evaporator assembly is not tripped. 3. Verify power from ON/OFF switch. <ol style="list-style-type: none"> (a) Turn ignition key switch to the OFF position (TM 9-2320-273-10 and TM 9-2320-283-10). (b) Disconnect wire connector A - C. (c) Turn ignition key switch to the ON position (TM 9-2320-273-10 and TM 9-2320-283-10). (d) Set A/C switch to ON position (WP 0005 00). (e) Check for 24 VDC on green wire terminal of wire connector "C" to vehicle ground. 4. Verify power to ON/OFF switch. <ol style="list-style-type: none"> (a) Turn ignition key switch to the OFF position (TM 9-2320-273-10 and TM 9-2320-283-10). (b) Remove switch box from console switch panel (WP 0021 00). 	<ol style="list-style-type: none"> 1. Select the ON position. 2. If ON/OFF switch is in the ON position, proceed to next step. 1. If breaker is tripped, reset circuit breaker. 2. If, after resetting circuit breaker, it remains tripped, proceed to step 9. 3. If circuit breaker is not tripped, proceed to next step. 1. If 24 VDC is indicated, proceed to step 6. 2. If 24 VDC is not indicated, proceed to next step.

MALFUNCTION	TEST OR INSPECTION	CORRECTIVE ACTION
A/C ELECTRICAL SYSTEM - CONTINUED		
<p>1. A/C System Does Not Function - Continued.</p>	<p>(c) Turn ignition key switch to the ON position (TM 9-2320-273-10 and TM 9-2320-283-10).</p> <p>(d) Check for 24 VDC on white wire connector of ON/OFF switch to vehicle ground.</p> <p>5. Verify power through ON/OFF switch.</p> <p>(a) Check for 24 VDC on green wire connector on ON/OFF switch to vehicle ground.</p> <p>(b) Turn ignition key switch to the OFF position (TM 9-2320-273-10 and TM 9-2320-283-10).</p> <p>(c) Return equipment to normal condition.</p> <p>6. Verify power from battery to evaporator assembly.</p> <p>(a) Turn ignition key switch to the OFF position (TM 9-2320-273-10 and TM 9-2320-283-10).</p> <p>(b) Disconnect two-pin power and ground harness connector at evaporator assembly (WP 0021 00).</p> <p>(c) Check for 24 VDC between red wire terminal and black wire terminal on power and ground harness connector.</p> <p>7. Verify ground wire continuity.</p> <p>(a) Check for continuity between black wire terminal on power and ground connector and vehicle ground.</p>	<p>1. If 24 VDC is not indicated, repair or replace white wire.</p> <p>2. If 24 VDC is indicated, proceed to next step.</p> <p>1. If 24 VDC is indicated, repair or replace green wire.</p> <p>2. If 24 VDC is not indicated, replace switch.</p> <p>1. If 24 VDC is indicated, proceed to step 8.</p> <p>2. If 24 VDC is not indicated, proceed to next step.</p> <p>1. If black wire has continuity, replace red wire and/or its connection to the battery terminal (WP 0021 00).</p> <p>2. If black wire does not have continuity, repair or replace black wire and/or its connection to the battery terminal (WP 0021 00).</p>

MALFUNCTION	TEST OR INSPECTION	CORRECTIVE ACTION
A/C ELECTRICAL SYSTEM - CONTINUED		
<p>1. A/C System Does Not Function - Continued.</p>	<p>(b) Return equipment to normal condition.</p> <p style="text-align: center;">NOTE</p> <p style="text-align: center;">Repeat step 8 for both orange wires at connector "B".</p> <p>8. Verify power from evaporator assembly.</p> <p>(a) Return equipment to normal condition.</p> <p>(b) Disconnect wiring harness connectors B - D (evaporator extension harness).</p> <p>(c) Turn ignition key switch to the ON position (TM 9-2320-273-10 and TM 9-2320-283-10).</p> <p>(d) Position A/C ON/OFF switch to ON position (WP 0004 00).</p> <p>(e) Check for 24 VDC on orange terminal of connector "B" to vehicle ground.</p> <p>9. Verify power at A/C unit circuit breaker.</p> <p>(a) Remove access cover from evaporator assembly (WP 0017 00).</p> <p>(b) Remove red wire terminal on circuit breaker (going to power relay inside evaporator assembly).</p> <p>(c) Check for 24 VDC on circuit breaker terminal.</p> <p>10. Verify operation of power relay.</p> <p>(a) Remove power relay.</p> <p>(b) Check continuity between terminal 86 and 85 on power relay.</p>	<p>1. If 24 VDC is indicated, proceed to <i>A/C System Energized but Evaporator Assembly Does Not Function.</i></p> <p>2. If 24 VDC is not indicated, proceed to next step.</p> <p>1. If 24 VDC is not indicated, replace circuit breaker (WP 0017 00).</p> <p>2. If 24 VDC is indicated proceed to next step.</p> <p>1. If infinity or a direct short is indicated, replace power relay (WP 0017 00).</p> <p>2. If infinity or a direct short is not indicated, proceed to next step.</p>

MALFUNCTION	TEST OR INSPECTION	CORRECTIVE ACTION
A/C ELECTRICAL SYSTEM - CONTINUED		
<p>1. A/C System Does Not Function - Continued.</p>	<p>(c) Return equipment to normal condition.</p> <p>11. Verify continuity of red wire from circuit breaker to power relay.</p> <p>(a) Turn ignition key switch to the OFF position (TM 9-2320-273-10 and TM 9-2320-283-10).</p> <p>(b) Remove power relay connector (WP 0017 00).</p> <p>(c) Check continuity between red wire terminal on power relay connector and red wire on circuit breaker.</p> <p>(d) Return equipment to normal condition.</p> <p>12. Verify orange wire continuity from power relay to connector "B".</p> <p>(a) Disconnect wiring harness connectors B - D.</p> <p>(b) Remove power relay connector (WP 0017 00).</p> <p>(c) Check continuity between orange wire terminal on power relay connector and orange wire on connector "B".</p> <p>(d) Return equipment to normal condition.</p> <p>13. Verify green wire continuity from power relay to connector "A".</p> <p>(a) Disconnect wiring harness connectors A - C.</p> <p>(b) Remove power relay connector (WP 0017 00).</p> <p>(c) Check continuity between green wire terminal on power relay connector and green wire on connector "A".</p> <p>(d) Return equipment to normal condition.</p>	<p>1. If continuity is not indicated, repair or replace red wire.</p> <p>2. If continuity is indicated, proceed to next step.</p> <p>1. If continuity is not indicated, repair or replace orange wire.</p> <p>2. If continuity is indicated, proceed to next step.</p> <p>1. If continuity is not indicated, repair or replace green wire.</p> <p>2. If continuity is indicated, proceed to next step.</p>

MALFUNCTION	TEST OR INSPECTION	CORRECTIVE ACTION
A/C ELECTRICAL SYSTEM - CONTINUED		
<p>1. A/C System Does Not Function - Continued.</p> <p>2. A/C System Energized But Evaporator Assembly Does Not Function.</p>	<p>14. Verify black wire continuity from power relay to ground connection.</p> <p>(a) Remove power relay connector (WP 0017 00).</p> <p>(b) Check continuity between black wire terminal on power relay connector and black wire ground connection on relay/thermostat bracket.</p> <p>(c) Return equipment to normal condition.</p> <p>1. Inspect fan motor. Ensure that fan motor is not seized.</p> <p>(a) Turn ignition key switch to the OFF position (TM 9-2320-273-10 and TM 9-2320-283-10).</p> <p>(b) Set A/C ON/OFF switch to the OFF position (WP 0004 00).</p> <p>(c) Remove access cover from evaporator assembly (WP 0017 00).</p> <p>(d) Attempt to spin fan motor.</p> <p>(e) Return equipment to normal condition.</p> <p>2. Verify operation of speed selector switch.</p> <p>(a) Turn ignition key switch to the ON position (TM 9-2320-273-10 and TM 9-2320-283-10).</p> <p>(b) Set A/C ON/OFF switch to the ON position (WP 0004 00).</p>	<p>1. If continuity is not indicated, repair or replace black wire.</p> <p>2. If continuity is indicated, replace power relay (WP 0017 00).</p> <p>1. If motor is seized, replace fan motor assembly (WP 0017 00).</p> <p>2. If motor is not seized, proceed to next step.</p>

A/C TROUBLESHOOTING PROCEDURES - CONTINUED

0013 00

MALFUNCTION	TEST OR INSPECTION	CORRECTIVE ACTION
A/C ELECTRICAL SYSTEM - CONTINUED		
2. A/C System Energized But Evaporator Assembly Does Not Function - Continued.	<p>(c) Check continuity between purple wire terminal and orange wire terminal on connector "C".</p> <p>(d) Return equipment to normal condition.</p> <p>5. Verify blower LOW speed circuit inside evaporator assembly.</p> <p>(a) Disconnect wiring harness connectors A - C.</p> <p>(b) Remove access cover from evaporator assembly (WP 0017 00).</p> <p>(c) Disconnect resistor speed control connector from resistor speed control.</p> <p>(d) Check continuity between purple wire terminal on connector "A" and purple wire terminal on resistor speed control connector.</p> <p>(e) Return equipment to normal condition.</p> <p>6. Verify selector switch MEDIUM speed setting.</p> <p>(a) Turn ignition key switch to the OFF position (TM 9-2320-273-10 and TM 9-2320-283-10).</p> <p>(b) Set A/C ON/OFF switch to the OFF position (WP 0004 00).</p> <p>(c) Remove selector switch box from console switch panel (WP 0017 00).</p> <p>(d) Set speed selector switch to MEDIUM (WP 0004 00).</p>	<p>1. If continuity is not indicated, repair or replace purple wire.</p> <p>2. If continuity is indicated, proceed to next step.</p> <p>1. If continuity is not indicated, repair or replace purple wire.</p> <p>2. If continuity is indicated, replace resistor speed control (WP 0017 00).</p>

MALFUNCTION	TEST OR INSPECTION	CORRECTIVE ACTION
A/C ELECTRICAL SYSTEM - CONTINUED		
<p>2. A/C System Energized But Evaporator Assembly Does Not Function - Continued.</p>	<p>(e) Check continuity between yellow wire terminal and orange wire terminal on speed selector switch.</p> <p>(f) Return equipment to normal condition.</p> <p>7. Verify blower MEDIUM speed circuit to evaporator assembly.</p> <p>(a) Disconnect wiring harness connectors A - C.</p> <p>(b) Set speed selector switch to MEDIUM (WP 0004 00).</p> <p>(c) Check continuity between yellow wire terminal and orange wire terminal on connector "C".</p> <p>(d) Return equipment to normal condition.</p> <p>8. Verify blower MEDIUM speed circuit inside evaporator assembly.</p> <p>(a) Disconnect wiring harness connectors A - C.</p> <p>(b) Remove access cover from evaporator assembly (WP 0017 00).</p> <p>(c) Disconnect resistor speed control connector from resistor speed control.</p> <p>(d) Check continuity between yellow wire terminal on connector "A" and yellow wire terminal on resistor speed control connector.</p> <p>(e) Return equipment to normal condition.</p>	<p>1. If continuity is not indicated, replace selector switch (WP 0017 00).</p> <p>2. If continuity is indicated, proceed to next step.</p> <p>1. If continuity is not indicated, repair or replace yellow wire.</p> <p>2. If continuity is indicated, proceed to next step.</p> <p>1. If continuity is not indicated, repair or replace yellow wire.</p> <p>2. If continuity is indicated, replace resistor speed control (WP 0017 00).</p>

MALFUNCTION	TEST OR INSPECTION	CORRECTIVE ACTION
A/C ELECTRICAL SYSTEM - CONTINUED		
<p>2. A/C System Energized But Evaporator Assembly Does Not Function - Continued.</p>	<p>9. Verify selector switch HIGH speed setting.</p> <ul style="list-style-type: none"> (a) Turn ignition key switch to the OFF position (TM 9-2320-273-10 and TM 9-2320-283-10). (b) Set A/C ON/OFF switch to the OFF position (WP 0004 00). (c) Remove selector switch box from console switch panel (WP 0017 00). (d) Set speed selector switch to HIGH (WP 0004 00). (e) Check continuity between red wire terminal and orange wire terminal on speed selector switch. (f) Return equipment to normal condition. <p>10. Verify blower HIGH speed circuit to evaporator assembly.</p> <ul style="list-style-type: none"> (a) Disconnect wiring harness connectors A - C. (b) Set speed selector switch to HIGH (WP 0004 00). (c) Check continuity between red wire terminal and orange wire terminal on connector "C". (d) Return equipment to normal condition. <p>11. Check blower HIGH speed circuit inside evaporator assembly.</p> <ul style="list-style-type: none"> (a) Disconnect wiring harness connectors A - C. (b) Remove access cover from evaporator assembly (WP 0017 00). 	<ul style="list-style-type: none"> 1. If continuity is not indicated, replace selector switch (WP 0017 00). 2. If continuity is indicated, proceed to next step. <ul style="list-style-type: none"> 1. If continuity is not indicated, repair or replace red wire. 2. If continuity is indicated, proceed to next step.

MALFUNCTION	TEST OR INSPECTION	CORRECTIVE ACTION
A/C ELECTRICAL SYSTEM - CONTINUED		
<p>2. A/C System Energized But Evaporator Assembly Does Not Function - Continued.</p>	<p>(c) Disconnect resistor speed control connector from resistor speed control.</p> <p>(d) Check continuity between red wire terminal on connector "A" and red wire terminal on resistor speed control connector.</p> <p>(e) Return equipment to normal condition.</p> <p>12. Verify power circuit to EMI filter.</p> <p>(a) Turn ignition key switch to the OFF position (TM 9-2320-273-10 and TM 9-2320-283-10).</p> <p>(b) Set A/C ON/OFF switch to the OFF position (WP 0004 00).</p> <p>(c) Remove blower motor assembly (WP 0017 00).</p> <p>(d) Disconnect connectors from blower motor assembly.</p> <p>(e) Check continuity between orange wire terminal on resistor speed control connector and orange wire terminal on EMI filter.</p> <p>(f) Return equipment to normal condition.</p> <p>13. Verify power circuit through EMI filter.</p> <p>(a) Check continuity between orange wire terminal on resistor speed control connector and red wire terminal on EMI filter.</p> <p>(b) Return equipment to normal condition.</p> <p>14. Verify power circuit to blower motor.</p> <p>(a) Check continuity between orange wire terminal on resistor speed control connector and red wire terminal that connects to blower motor.</p>	<p>1. If continuity is not indicated, repair or replace red wire.</p> <p>2. If continuity is indicated, replace resistor speed control (WP 0017 00).</p> <p>1. If continuity is not indicated, repair or replace orange wire.</p> <p>2. If continuity is indicated, proceed to next step.</p> <p>1. If continuity is not indicated, replace EMI filter (WP 0017 00).</p> <p>2. If continuity is indicated, proceed to next step.</p> <p>1. If continuity is not indicated, replace red wire.</p> <p>2. If continuity is indicated, proceed to next step.</p>

MALFUNCTION	TEST OR INSPECTION	CORRECTIVE ACTION
A/C ELECTRICAL SYSTEM - CONTINUED		
<p>2. A/C System Energized But Evaporator Assembly Does Not Function - Continued.</p>	<p>(b) Return equipment to normal condition.</p> <p>15. Verify EMI filter for connection to ground.</p> <p>(a) Check continuity between ground terminal (three black wires) below EMI filter and black wire on line side of EMI filter.</p> <p>(b) Return equipment to normal condition.</p> <p>16. Verify ground through EMI filter.</p> <p>(a) Check continuity between ground terminal (three black wires) below EMI filter and black wire terminal on load side of EMI filter.</p> <p>(b) Return equipment to normal condition.</p> <p>17. Verify ground to blower motor.</p> <p>(a) Check continuity between ground terminal (three black wires) below EMI filter and black wire terminal that connects to blower motor.</p> <p>(b) Return equipment to normal condition.</p>	<p>1. If continuity is not indicated, repair or replace black wire.</p> <p>2. If continuity is indicated, proceed to next step.</p> <p>1. If continuity is not indicated, replace EMI filter (WP 0017 00).</p> <p>2. If continuity is indicated, proceed to next step.</p> <p>1. If continuity is not indicated, replace black wire.</p> <p>2. If continuity is indicated, replace blower motor (WP 0017 00).</p>
<p>3. Only One Condenser Fan Operates.</p>	<p>1. Verify power non-operational condenser fan.</p> <p>(a) Disconnect wiring connector of non-operational condenser fan.</p> <p>(b) Turn ignition key switch to the ON position (TM 9-2320-273-10 and TM 9-2320-283-10).</p> <p>(c) Set A/C switch in the ON position (WP 0005 00).</p> <p>(d) Check for 24 VDC between blue wire terminal and black wire terminal (ground) of connector disconnected from condenser fan (cable to EMI filter assembly).</p>	<p>1. If 24 VDC is indicated, replace non-operational condenser fan (WP 0017 00).</p> <p>2. If 24 VDC is not indicated, proceed to next step.</p>

MALFUNCTION	TEST OR INSPECTION	CORRECTIVE ACTION
A/C ELECTRICAL SYSTEM - CONTINUED		
<p>3. Only One Condenser Fan Operates - Continued.</p>	<p>(e) Return equipment to normal condition.</p> <p>2. Verify power circuit to EMI filter.</p> <p>(a) Turn ignition key switch to the OFF position (TM 9-2320-273-10 and TM 9-2320-283-10).</p> <p>(b) Set A/C ON/OFF switch to the OFF position (WP 0004 00).</p> <p>(c) Disconnect wiring connector of non-operational condenser fan.</p> <p>(d) Disconnect wiring harness connectors F - H (receiver/dryer extension harness from condenser cable) (WP 0021 00).</p> <p>(e) Remove EMI filter assembly from condenser assembly (WP 0018 00).</p> <p>(f) Remove cover from EMI filter connected to non-operational condenser fan.</p> <p>(g) Check continuity from green wire terminal on connector "H" and green wire terminal on EMI filter.</p> <p>(h) Return equipment to normal condition.</p> <p>3. Verify power circuit through EMI filter.</p> <p>(a) Check continuity from green wire terminal on EMI filter and blue wire terminal on EMI filter.</p> <p>(b) Return equipment to normal condition.</p> <p>4. Verify power circuit to condenser fan.</p> <p>(a) Check continuity from blue wire terminal on EMI filter and blue wire terminal on non operational condenser fan connector.</p> <p>(b) Return equipment to normal condition.</p>	<p>1. If continuity is not indicated, repair or replace green wire.</p> <p>2. If continuity is indicated, proceed to next step.</p> <p>1. If continuity is not indicated, replace EMI filter (WP 0018 00).</p> <p>2. If continuity is indicated, proceed to next step.</p> <p>1. If continuity is not indicated, repair or replace blue wire.</p> <p>2. If continuity is indicated, proceed to next step.</p>

MALFUNCTION	TEST OR INSPECTION	CORRECTIVE ACTION
A/C ELECTRICAL SYSTEM - CONTINUED		
<p>3. Only One Condenser Fan Operates - Continued.</p>	<p>5. Verify ground circuit to EMI filter.</p> <p>(a) Check continuity from black wire terminal on connector "H" and black wire terminal on line connection of EMI filter.</p> <p>(b) Return equipment to normal condition.</p> <p>6. Verify ground circuit through EMI filter.</p> <p>(a) Check continuity from black wire terminal on line connection of EMI filter and black wire terminal on load connection of EMI filter.</p> <p>(b) Return equipment to normal condition.</p> <p>7. Verify ground to condenser fan.</p> <p>(a) Check continuity from black wire terminal on load connection of EMI filter and black wire terminal on non operational condenser fan connector.</p> <p>(b) Return equipment to normal condition.</p>	<p>1. If continuity is not indicated, repair or replace green wire.</p> <p>2. If continuity is indicated, proceed to next step.</p> <p>1. If continuity is not indicated, replace EMI filter (WP 0018 00).</p> <p>2. If continuity is indicated, proceed to next step.</p> <p>1. If continuity is not indicated, repair or replace blue wire.</p> <p>2. If continuity is indicated, replace non-operational condenser fan (WP 0017 00).</p>
<p>4. Evaporator Assembly Works But Condenser Fan Does Not.</p>	<p>1. Verify operation of condenser fan pressure switch on receiver/dryer.</p> <p>(a) Start engine (TM 9-2320-273-10 and TM 9-2320-283-10).</p> <p>(b) Set A/C ON/OFF switch to the ON position (WP 0005 00).</p> <p>(c) Disconnect condenser fan pressure switch connector on receiver/dryer (connector with orange and yellow wires) (WP 0019 00).</p> <p>(d) Install jumper wire across condenser fan switch connector.</p> <p>(e) Verify condenser fans operation.</p>	<p>1. If condenser fans do not operate, proceed to step 3.</p> <p>2. If condenser fans operate, proceed to next step.</p>

MALFUNCTION	TEST OR INSPECTION	CORRECTIVE ACTION
A/C ELECTRICAL SYSTEM - CONTINUED		
<p>4. Evaporator Assembly Works But Condenser Fan Does Not - Continued.</p>	<p>(f) Return equipment to normal condition.</p> <p>2. Verify A/C system pressures (WP 0015 00). Return equipment to normal condition.</p> <p>3. Verify power from condenser fan relay.</p> <p>(a) Disconnect wiring harness connectors F - H (receiver/dryer extension harness from condenser cable) (WP 0021 00).</p> <p>(b) Turn ignition key switch to the ON position (TM 9-2320-273-10 and TM 9-2320-283-10).</p> <p>(c) Set A/C ON/OFF switch to the ON position (WP 0004 00).</p> <p>(d) Check for 24 VDC between green wire terminal and black wire terminal (ground) on connector "F".</p> <p>(e) Return equipment to normal condition.</p> <p>4. Verify power circuit to EMI filters.</p> <p>(a) Turn ignition key switch to the OFF position (TM 9-2320-273-10 and TM 9-2320-283-10).</p> <p>(b) Set A/C ON/OFF switch to the OFF position (WP 0004 00).</p> <p>(c) Remove EMI filter assembly from condenser assembly (WP 0018 00).</p> <p>(d) Remove cover from both EMI filters.</p> <p>(e) Check continuity from green wire terminal connector "H" and green wire terminal on line connection of either EMI filter.</p>	<p>1. If system is operating within normal parameters, replace pressure switch (WP 0015 00).</p> <p>2. If system is not operating within normal parameters, inspect system for leaks (WP 0015 00).</p> <p>1. If 24 VDC is not indicated, proceed to step 6.</p> <p>2. If 24 VDC is indicated, proceed to next step.</p> <p>1. If continuity is not indicated, repair or replace green wire.</p> <p>2. If continuity is indicated, proceed to next step.</p>

MALFUNCTION	TEST OR INSPECTION	CORRECTIVE ACTION
A/C ELECTRICAL SYSTEM - CONTINUED		
<p>4. Evaporator Assembly Works But Condenser Fan Does Not - Continued.</p>	<p>(f) Return equipment to normal condition.</p> <p>5. Verify ground circuit to EMI filter.</p> <p>(a) Check continuity from black wire terminal on connector "H" and black wire terminal on line connection of EMI filter.</p> <p>(b) Return equipment to normal condition.</p> <p>6. Verify power connection through receiver/dryer extension harness.</p> <p>(a) Turn ignition key switch to the OFF position (TM 9-2320-273-10 and TM 9-2320-283-10).</p> <p>(b) Set A/C ON/OFF switch to the OFF position (WP 0004 00).</p> <p>(c) Disconnect connector E - G (evaporator extension harness at connection forward of receiver/dryer).</p> <p>(d) Check continuity of green wire terminal connector "F" and green wire terminal connector "G".</p> <p>(e) Return equipment to normal condition.</p> <p>7. Verify ground connection through receiver/dryer extension harness.</p> <p>(a) Check continuity of black wire terminal connector "F" and black wire terminal connector "G".</p> <p>(b) Return equipment to normal condition.</p> <p>8. Verify power connection to condenser fans pressure switch.</p>	<p>1. If continuity is indicated, replace condenser fans (WP 0018 00).</p> <p>2. If continuity is not indicated, repair or replace black wire.</p> <p>1. If continuity is not indicated, repair or replace green wire.</p> <p>2. If continuity is indicated, proceed to next step.</p> <p>1. If continuity is not indicated, repair or replace black wire.</p> <p>2. If continuity is indicated, proceed to next step.</p>

MALFUNCTION	TEST OR INSPECTION	CORRECTIVE ACTION
<i>A/C ELECTRICAL SYSTEM - CONTINUED</i>		
<p>4. Evaporator Assembly Works But Condenser Fan Does Not - Continued.</p>	<p>(a) Check continuity of orange wire terminal condenser fan pressure switch and orange wire terminal connector "G".</p> <p>(b) Return equipment to normal condition.</p> <p>9. Verify power connection from condenser fans pressure switch.</p> <p>(a) Check continuity of yellow wire terminal condenser fan pressure switch and yellow wire terminal connector "G".</p> <p>(b) Return equipment to normal condition.</p> <p>10. Verify power connection through evaporator extension harness.</p> <p>(a) Disconnect connector B - D (evaporator extension harness at evaporator assembly).</p> <p>(b) Check continuity of green wire terminal connector "E" and green wire terminal connector "D".</p> <p>(c) Return equipment to normal condition.</p> <p>11. Verify ground connection through evaporator extension harness.</p> <p>(a) Check continuity of black wire terminal connector "E" and black wire terminal connector "D".</p> <p>(b) Return equipment to normal condition.</p> <p>12. Verify power connection for condenser fans pressure switch through evaporator extension harness.</p>	<p>1. If continuity is not indicated, repair or replace orange wire.</p> <p>2. If continuity is indicated, proceed to next step.</p> <p>1. If continuity is not indicated, repair or replace yellow wire.</p> <p>2. If continuity is indicated, proceed to next step.</p> <p>1. If continuity is not indicated, repair or replace green wire.</p> <p>2. If continuity is indicated, proceed to next step.</p> <p>1. If continuity is not indicated, repair or replace black wire.</p> <p>2. If continuity is indicated, proceed to next step.</p>

MALFUNCTION	TEST OR INSPECTION	CORRECTIVE ACTION
A/C ELECTRICAL SYSTEM - CONTINUED		
<p>4. Evaporator Assembly Works But Condenser Fan Does Not - Continued.</p>	<p>(a) Check continuity of orange wire terminal connector "E" and orange wire terminal connector "D".</p> <p>(b) Return equipment to normal condition.</p> <p>13. Verify power connection from condenser fans pressure switch through evaporator extension harness.</p> <p>(a) Check continuity of yellow wire terminal connector "E" and yellow wire terminal connector "D".</p> <p>(b) Return equipment to normal condition.</p> <p>14. Verify power connection to connector "B".</p> <p>(a) Turn ignition key switch to the OFF position (TM 9-2320-273-10 and TM 9-2320-283-10).</p> <p>(b) Set A/C ON/OFF switch to the OFF position (WP 0004 00).</p> <p>(c) Remove access cover from evaporator assembly (WP 0017 00).</p> <p>(d) Disconnect resistor speed control connector from resistor speed control and connectors for blower fan (WP 0017 00).</p> <p>(e) Remove condenser relay connector (WP 0017 00).</p> <p>(f) Check continuity between green wire terminal on condenser relay connector and green wire terminal on connector "B".</p> <p>(g) Return equipment to normal condition.</p> <p>15. Verify ground connection to connector "B".</p>	<p>1. If continuity is not indicated, repair or replace orange wire.</p> <p>2. If continuity is indicated, proceed to next step.</p> <p>1. If continuity is not indicated, repair or replace yellow wire.</p> <p>2. If continuity is indicated, proceed to next step.</p> <p>1. If continuity is not indicated, repair or replace green wire.</p> <p>2. If continuity is indicated, proceed to next step.</p>

MALFUNCTION	TEST OR INSPECTION	CORRECTIVE ACTION
A/C ELECTRICAL SYSTEM - CONTINUED		
<p>4. Evaporator Assembly Works But Condenser Fan Does Not - Continued.</p>	<p>(a) Check continuity between ground terminal below EMI filter inside evaporator assembly and black wire terminal on connector "B".</p> <p>(b) Return equipment to normal condition.</p> <p>16. Verify power connection for condenser fans pressure switch from evaporator assembly.</p> <p>(a) Check continuity of orange wire terminal connector "B" and orange wire terminal on condenser relay connector.</p> <p>(b) Return equipment to normal condition.</p> <p>17. Verify power connection from connector "B".</p> <p>(a) Check continuity between yellow wire terminal on condenser relay connector and yellow wire terminal on connector "B".</p> <p>(b) Return equipment to normal condition.</p>	<p>1. If continuity is not indicated, repair or replace black wire.</p> <p>2. If continuity is indicated proceed to next step.</p> <p>1. If continuity is not indicated, repair or replace orange wire.</p> <p>2. If continuity is indicated, proceed to next step.</p> <p>1. If continuity is not indicated, repair or replace black wire.</p> <p>2. If continuity is indicated, replace condenser fan relay (WP 001700).</p>
<p>5. Evaporator Assembly Works But Compressor Does Not.</p>	<p>1. Verify power at compressor.</p> <p>(a) Disconnect black wire with white stripe at compressor.</p> <p>(b) Turn ignition key switch to the ON position (TM 9-2320-273-10 and TM 9-2320-283-10).</p> <p>(c) Set A/C ON/OFF switch to the ON position (WP 0004 00).</p> <p>(d) Check for 24 VDC on black wire with white stripe connector to vehicle ground.</p> <p>2. Verify ground connection at compressor frame.</p>	<p>1. If 24 VDC is not indicated, proceed to step 4.</p> <p>2. If 24 VDC is indicated, proceed to next step.</p>

MALFUNCTION	TEST OR INSPECTION	CORRECTIVE ACTION
A/C ELECTRICAL SYSTEM - CONTINUED		
<p>5. Evaporator Assembly Works But Compressor Does Not - Continued.</p>	<p>(a) Turn ignition key switch to the OFF position (TM 9-2320-273-10 and TM 9-2320-283-10).</p> <p>(b) Set A/C ON/OFF switch to the OFF position (WP 0004 00).</p> <p>(c) Check for continuity between compressor frame and vehicle ground.</p> <p>(d) Return equipment to normal condition.</p> <p>3. Verify operation of compressor clutch.</p> <p>(a) Start engine (TM 9-2320-273-10 and TM 9-2320-283-10).</p> <p>(b) Set A/C ON/OFF switch to the ON position (WP 0004 00).</p> <p>(c) Verify compressor clutch engages.</p> <p>4. Check high pressure switch on receiver/dryer for proper operation.</p> <p>(a) Turn ignition key switch to the OFF position (TM 9-2320-273-10 and TM 9-2320-283-10).</p> <p>(b) Set A/C ON/OFF switch to the OFF position (WP 0004 00).</p> <p>(c) Disconnect wiring connector at high pressure switch on receiver/dryer (white and orange wires) (WP 0019 00).</p> <p>(d) Install jumper wire across high pressure switch connector.</p> <p>(e) Start engine (TM 9-2320-273-10 and TM 9-2320-283-10).</p> <p>(f) Set A/C ON/OFF switch to the ON position (WP 0004 00).</p>	<p>1. If continuity is not indicated, repair ground on compressor.</p> <p>2. If continuity is indicated, proceed to next step.</p> <p>1. If compressor clutch engages, proceed to step 14.</p> <p>2. If compressor clutch does not engage, proceed to next step.</p>

MALFUNCTION	TEST OR INSPECTION	CORRECTIVE ACTION
A/C ELECTRICAL SYSTEM - CONTINUED		
<p>5. Evaporator Assembly Works But Compressor Does Not - Continued.</p>	<p>(g) Verify compressor clutch engages.</p> <p>5. Verify system for normal high side operating pressure (WP 0015 00).</p> <p>Return equipment to normal condition.</p> <p>6. Verify power at high pressure switch on receiver/dryer.</p> <p>(a) Turn ignition key switch to the OFF position (TM 9-2320-273-10 and TM 9-2320-283-10).</p> <p>(b) Set A/C ON/OFF switch to the OFF position (WP 0004 00).</p> <p>(c) Disconnect wire connector at high pressure switch (white and orange wire) on receiver/dryer.</p> <p>(d) Turn ignition key switch to the ON position (TM 9-2320-273-10 and TM 9-2320-283-10).</p> <p>(e) Set A/C ON/OFF switch to the ON position (WP 0004 00).</p> <p>(f) Check for 24 VDC on orange wire terminal on high pressure switch connector to vehicle ground.</p> <p>7. Verify power on orange wire at connector "E".</p> <p>(a) Turn ignition key switch to the OFF position (TM 9-2320-273-10 and TM 9-2320-283-10).</p> <p>(b) Set A/C ON/OFF switch to the OFF position (WP 0004 00).</p> <p>(c) Disconnect wiring harness connectors E - G.</p>	<p>1. If compressor clutch does not engage, proceed to step 6.</p> <p>2. If compressor clutch engages, proceed to next step.</p> <p>1. If system pressure is within parameters, replace high pressure switch on receiver/dryer (WP 0019 00).</p> <p>2. If system pressure is not within parameters, inspect A/C system for leaks (WP 0015 00).</p> <p>1. If 24 VDC is indicated, proceed to step 9.</p> <p>2. If 24 VDC is not indicated, proceed to next step.</p>

A/C TROUBLESHOOTING PROCEDURES - CONTINUED

0013 00

MALFUNCTION	TEST OR INSPECTION	CORRECTIVE ACTION
A/C ELECTRICAL SYSTEM - CONTINUED		
<p>5. Evaporator Assembly Works But Compressor Does Not - Continued.</p>	<p>(d) Turn ignition key switch to the ON position (TM 9-2320-273-10 and TM 9-2320-283-10).</p> <p>(e) Set A/C ON/OFF switch to the ON position (WP 0004 00).</p> <p>(f) Check for 24 VDC on orange wire terminal on connector "E" to vehicle ground.</p> <p>(g) Return equipment to normal condition.</p> <p>8. Verify power on orange wire at connector "B".</p> <p>(a) Turn ignition key switch to the OFF position (TM 9-2320-273-10 and TM 9-2320-283-10).</p> <p>(b) Set A/C ON/OFF switch to the OFF position (WP 0004 00).</p> <p>(c) Disconnect wiring harness connectors B - D.</p> <p>(d) Turn ignition key switch to the ON position (TM 9-2320-273-10 and TM 9-2320-283-10).</p> <p>(e) Set A/C ON/OFF switch to the ON position (WP 0004 00).</p> <p>(f) Check for 24 VDC on orange wire terminal on connector "B" to vehicle ground.</p> <p>(g) Return equipment to normal condition.</p> <p>9. Verify white wire continuity from high pressure switch to connector "G".</p>	<p>1. If 24 VDC is indicated, repair or replace orange wire between connector "G" and high pressure switch.</p> <p>2. If 24 VDC is not indicated, proceed to next step.</p> <p>1. If 24 VDC is indicated, repair or replace orange wire between connector "D" and connector "E".</p> <p>2. If 24 VDC is not indicated, repair or replace orange wire inside evaporator assembly to connector "B".</p>

MALFUNCTION	TEST OR INSPECTION	CORRECTIVE ACTION
A/C ELECTRICAL SYSTEM - CONTINUED		
<p>5. Evaporator Assembly Works But Compressor Does Not - Continued.</p>	<p>(a) Turn ignition key switch to the OFF position (TM 9-2320-273-10 and TM 9-2320-283-10).</p> <p>(b) Set A/C ON/OFF switch to the OFF position (WP 0004 00).</p> <p>(c) Check continuity between white wire terminal on high pressure switch and white wire terminal on connector "G".</p> <p>(d) Return equipment to normal condition.</p> <p>10. Verify white wire continuity from connector "E" to connector "D".</p> <p>(a) Disconnect wiring harness connectors B - D.</p> <p>(b) Check continuity between white wire terminal on connector "E" and white wire terminal on connector "D".</p> <p>(c) Return equipment to normal condition.</p> <p>11. Verify white wire continuity from thermostat to connector "B".</p> <p>(a) Remove access cover from evaporator assembly (WP 0017 00).</p> <p>(b) Check continuity from white wire terminal on connector "B" and white wire terminal on thermostat.</p> <p>(c) Return equipment to normal condition.</p> <p>12. Check thermostat for continuity. Thermostat should be closed at temperatures above 40°F.</p> <p>(a) Remove relay/thermostat bracket (WP 0017 00).</p>	<p>1. If continuity is not indicated, repair or replace white wire.</p> <p>2. If continuity is indicated, proceed to next step.</p> <p>1. If continuity is not indicated, repair or replace white wire.</p> <p>2. If continuity is indicated, proceed to next step.</p> <p>1. If continuity is not indicated, repair white wire.</p> <p>2. If continuity is indicated, proceed to next step.</p>

MALFUNCTION	TEST OR INSPECTION	CORRECTIVE ACTION
<i>A/C ELECTRICAL SYSTEM - CONTINUED</i>		
<p>5. Evaporator Assembly Works But Compressor Does Not - Continued.</p>	<p>(b) Check continuity between two terminal of thermostat.</p> <p>(c) Return equipment to normal condition.</p> <p>13. Verify black wire with white stripe continuity from thermostat to compressor.</p> <p>(a) Remove black wire with white stripe connection to compressor.</p> <p>(b) Check continuity of black wire with white stripe on thermostat to connection removed from compressor.</p> <p>(c) Return equipment to normal condition.</p> <p>14. Troubleshoot compressor to ensure it is not seized. Refer to <i>General Troubleshooting</i>, step 2 in this work package.</p>	<p>1. If continuity is not indicated, replace thermostat (WP 0017 00).</p> <p>2. If continuity is indicated, proceed to next step.</p> <p>1. If continuity is not indicated, repair black wire with white stripe.</p> <p>2. If continuity is indicated, proceed to next step.</p>

MALFUNCTION	CAUSE OR TEST	CORRECTIVE ACTION
A/C SYSTEM PRESSURE DIAGNOSIS		
<p>1. High Side and Low Side Pressure Normal and Evaporator Assembly Not Producing Cold Air.</p>	<p>Excessive oil in system.</p>	<p>Restore proper oil level in compressor (WP 0015 00).</p>
<p>2. High Side Pressure Normal to High - Low Side Pressure Normal to High.</p>	<p>Moisture in system. Moisture freezes, temporarily stopping cycle; normal system operation returns when ice melts.</p>	<p>Replace receiver/dryer (WP 0019 00).</p>
<p>3. High Side Pressure Low - Low Side Pressure Low.</p>	<p>1. Leak test A/C system (WP 0015 00). 2. Incorrect charge.</p>	<p>Repair or replace any leaks found in system. If no leaks are found, proceed to step 2. Recharge system (WP 0015 00).</p>
<p>4. High Side Pressure Low - Low Side Pressure Zero to Negative - Frost on Tubes from Receiver/Dryer to Evaporator Assembly.</p>	<p>Refrigerant flow obstructed in receiver/dryer.</p>	<p>Replace receiver/dryer (WP 0019 00).</p>
<p>5. High Side Pressure Low - Low Pressure Side High.</p>	<p>1. Internal leak in compressor or compressor mechanically broken. 2. Compressor drive belt slipping.</p>	<p>Replace compressor (WP 0016 00). Adjust drive belt tension (WP 0016 00).</p>
<p>6. High Side Pressure High - Low Pressure Side Low.</p>	<p>1. Inspect system for kinked or damaged hoses. 2. Restriction in condenser.</p>	<p>Replace damaged hose (WP 0020 00). If no damage is found, proceed to step 2. Replace condenser (WP 0018 00).</p>
<p>7. High Side Pressure High - Low Pressure Side High - Low Side Lines Hot to Touch.</p>	<p>1. Inspect system for kinked or damaged hoses. 2. Verify system for air contamination.</p>	<p>Replace damaged hoses (WP 0020 00). If no damaged hoses are found, proceed to step 2. Leak test system (WP 0015 00). Repair as necessary.</p>
<p>8. High Side Pressure High - Low Pressure Side High.</p>	<p>1. Condenser fins obstructed. 2. Condenser cooling fans not working properly. 3. Refrigerant system overcharged. 4. Expansion valve not operating correctly.</p>	<p>Clean condenser fins. Troubleshoot condenser fans. Proceed to correct symptom (WP 0012 00). Recover refrigerant and recharge system (WP 0015 00). Replace expansion valve (WP 0017 00).</p>

END OF WORK PACKAGE

CHAPTER 5
UNIT AND DIRECT SUPPORT MAINTENANCE INSTRUCTIONS

GENERAL MAINTENANCE INSTRUCTIONS

0014 00

THIS WORK PACKAGE COVERS

Scope	Standard Tool Requirements
Work Safety	Use of Thread Adhesive
General Information	Use of Sealant
Cleaning Instructions	Applying Torque
Inspection Instructions	Tagging Instructions
Painting Instructions	

INITIAL SETUP**Maintenance Level**

Unit

Tools and Special Tools

Tool Kit, General Mechanic's (Item 9, WP 0024 00)

Shop Equipment, Common No. 1 (Item 6, WP 0024 00)

Materials/Parts

Adhesive, Thread (Item 1, WP 0025 00)

Cleaning Compound, Solvent, Type III (Item 2, WP 0025 00)

Cloth, Abrasive (Item 3, WP 0025 00)

Materials/Parts - Continued

Detergent, General Purpose, Liquid (Item 5, WP 0025 00)

Oil, Lubricating, OE/HDO-10 (Item 7, WP 0025 00)

Rag, Wiping (Item 9, WP 0025 00)

Tag, Marker (Item 13, WP 0025 00)

References

TB 43-0209

TB 43-0242

TM 9-2320-273-10

TM 9-2320-283-10

TM 9-247

SCOPE

1. These general maintenance instructions contain general shop practices and specific methods you must be familiar with to properly install and maintain the Air Conditioning Kit.
2. Read and understand these practices and methods before starting maintenance tasks on the armor kit.

WORK SAFETY

1. Before starting a task, think about the risks and hazards to your safety as well as others. Wear protective gear such as safety goggles or lenses, face shield, safety shoes, and gloves. Protect yourself against injury.
2. Observe all WARNINGS, CAUTIONS, and NOTES.
3. When lifting heavy parts, have someone help you. Make sure that lifting equipment is working properly, that it is suitable for the task assigned, of sufficient load capacity, and is secured against slipping.
4. Always use power tools carefully.

GENERAL MAINTENANCE INSTRUCTIONS - CONTINUED

0014 00

WORK SAFETY - CONTINUED

5. Before beginning a procedure, ensure work tool is lowered to ground and the following conditions have been observed, unless otherwise specified:
 - a. Vehicle must be parked on level ground wheel chocked with parking/emergency brake applied (TM 9-2320-273-10 and TM 9-2320-283-10).
 - b. Transmission must be in N (Neutral) (TM 9-2320-273-10 and TM 9-2320-283-10).
 - c. Engine must be OFF (TM 9-2320-273-10 and TM 9-2320-283-10).
 - d. Ignition key switch must be in the OFF position (TM 9-2320-273-10 and TM 9-2320-283-10).
 - e. If equipped, battery disconnect switch must be in the OFF position (TM 9-2320-273-10 and TM 9-2320-283-10).

GENERAL INFORMATION

1. Before beginning a task, find out how much teardown is needed to fix the equipment as described in this bulletin. Sometimes complete teardown is not necessary. Remove components only as far as necessary to replace damaged or broken parts.
2. All tags and forms attached to the equipment must be checked to learn the reason for removal from service. Check all Modification Work Orders (MWOs) and Technical Bulletins (TBs) for equipment changes and updates.
3. Replace all locknuts and lockwashers removed during procedure.
4. Inspect seals for damage. Replace seals if damaged.

CLEANING INSTRUCTIONS

1. **General.**
 - a. The importance of cleaning must be thoroughly understood by maintenance personnel. Great care and effort are required in cleaning. Dirt and foreign material are a constant threat to satisfactory maintenance.
 - b. The following should apply to all cleaning operations:
 - (1) Keep all related parts and components together. Do not mix parts.
 - (2) Clean all parts before inspection and before installation.
 - (3) To prevent contamination, hands should be kept free of accumulation of grease, which can collect dust, dirt, or grit.

CLEANING INSTRUCTIONS - CONTINUED2. **Cleaning Instructions.****WARNING**

- Solvent cleaning compound MIL-PRF-680 Type II and III may be irritating to the eyes and skin. Use protective gloves and goggles. Use in well-ventilated areas. Use respirator as needed. Accidental ingestion can cause irritation of digestive tract and respiratory tract, may cause lung and central nervous system damage. Can be fatal if swallowed. Inhalation of high/massive concentrations can cause coma or be fatal. First aid for ingestion: do not induce vomiting. Seek immediate medical attention. First aid for skin contact: remove contaminated clothing. Wash skin thoroughly with soap and water. If symptoms persist, seek medical attention. First aid for eye contact: flush with water for 15 minutes or until irritation subsides. If symptoms persist, seek medical attention. First aid for inhalation: move to fresh air. If not breathing, provide artificial respiration. If symptoms persist, seek medical attention. Keep away from open flames and other sources of ignition.
 - The flashpoint for type II solvent cleaning compound is 141-198°F (61-92°C) and type III is 200-241°F (93-116°C).
 - Improper cleaning methods and use of unauthorized cleaning solvents may injure personnel and damage equipment.
 - Fire extinguishers should be placed nearby when using solvent cleaning compound.
 - Cloths or rags saturated with solvent cleaning compound must be disposed of IAW authorized facilities' procedures.
 - Eye shields must be worn when cleaning with a wire brush. Flying rust and metal particle may cause injury.
 - Failure to follow these warnings may result in injury or death to personnel.
- a. Use solvent cleaning compound to clean any surface coated with grease or oil.

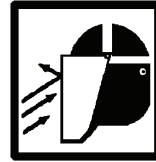
CLEANING INSTRUCTIONS - CONTINUED**WARNING****COMPRESSED AIR**

Particles blown by compressed air are hazardous. DO NOT exceed 15 psi (103 kPa) nozzle pressure when drying parts with compressed air. Use a maximum of 30 psi (207 kPa) when cleaning components. DO NOT direct compressed air against human skin. Make sure air stream is directed away from user and other personnel in the area. To prevent injury, user must wear protective goggles or face shield. Failure to follow this warning may result in injury or death to personnel.

- b. Clear out all drilled or tapped (threaded) holes with compressed air to remove dirt and solvent cleaning compound.
- c. Wash externally exposed parts, not subject to grease and oil, with detergent and water. Rinse thoroughly and air dry.
- d. Remove old sealing compound using a wire brush and solvent cleaning compound.
- e. Clean all rusted surfaces using a wire brush and abrasive cloth.
- f. After cleaning, cover or wrap all parts to protect them from dust and dirt. Any part that is subject to rust should be lightly coated with lubricating oil.

INSPECTION INSTRUCTIONS

1. **General.** All components and parts must be carefully inspected to determine if they are serviceable for reuse or if they must be replaced.
2. **Drilled and Tapped (Threaded) Holes.**
 - a. Inspect for wear, distortion (stretching), cracks, or any other damage in or around holes.
 - b. Inspect threaded areas for wear, distortion, or evidence of cross-threading.
 - c. If damage is noted, entire part should be replaced.
3. **Armor Plates.**
 - a. Inspect for breaks, cracks, dents, rust damage, and sharp edges.
 - b. Inspect areas around studs, screw openings, and edges.

WARNING

To ensure survivability of personnel, welding repairs on armor set are NOT authorized. If armor plates are damaged, they must be replaced. Failure to follow this warning may cause failure of armor, resulting in injury or death to personnel.

- c. Replace any damaged armor plate. DO NOT repair by welding.
4. **Bolts and Screws.** Replace if threads are damaged, bent, loose, or stretched.
5. **Studs.** If studs are damaged, repair or replace as necessary.
6. **Rubber Seals.** Replace seal if damaged, cracked, or shows signs of excessive wear.

PAINTING INSTRUCTIONS**CAUTION**

- Whenever paint is applied, care must be taken to prevent covering up installation aid markings (THIS SIDE UP, up arrows ↑, etc.). These installation aid markings must be protected during paint application by using masking tape, paper, etc.
- Whenever paint is applied, avoid painting rubber or glass components.

Parts must be painted in accordance with TB 43-0209, *Color, Marking, and Camouflage Painting of Military Vehicles, Construction Equipment, and Materials Handling Equipment*, and TB 43-0242, *CARC Spot Painting*.

STANDARD TOOL REQUIREMENTS

1. The following are general practices regarding the use of tools:
 - a. Always use the proper tool kit and tools for the procedure being performed.
 - b. Ensure tools are clean and lubricated to reduce wear and to prevent rust.
 - c. Keep track of tools. Do not be careless with them.
 - d. Return tools to toolbox when finished with repair or maintenance.
 - e. Return toolboxes and tools to tool storage when not in use.
 - f. Inventory tools before and after each use.
2. Some maintenance tasks may require special or fabricated tools. The “Initial Setup” of the procedure will specify any special or fabricated tools needed to perform that procedure. Use these special tools only for the maintenance procedures for which they are designed or called out. If you are unfamiliar with a required tool, see your supervisor.

USE OF THREAD ADHESIVE**WARNING**

Use caution when using adhesives and sealants. Prolonged inhalation of vapors can cause lung irritation. Contact with skin can cause dermatitis. Wear gloves and safety goggles and use product in a well-ventilated area away from open flame. If ingested, keep individual calm and seek medical attention. DO NOT induce vomiting. If contact with skin or eyes is made, flush thoroughly with water. Dispose of cleanup rags IAW local policy and ordinances. Failure to follow this warning may cause injury to personnel.

NOTE

Selected bolts and screws require use of adhesive during installation of the armor set, or when replacing armor kit components. Generally, if no locking fastener (i.e., locknut or lockwasher) is used, thread adhesive is required.

USE OF SEALANT

1. When applying sealant, follow manufacturer’s instructions on label of container.
2. Sealant should be applied with an even and continuous 1/4 in. bead along mating surfaces. Make semi-circular pattern around bolt holes and studs.

APPLYING TORQUE

1. When tightening fasteners, use torque value as specified in *Torque Limits* (WP 0026 00).
2. If a unique torque value is required, it will be provided in the procedural step of the task.

TAGGING INSTRUCTIONS

1. Use marker tags to identify all electrical wires and any other parts which may be hard to identify or replace later. Fasten tags to parts during removal by wrapping wire fasteners around or through parts and twisting ends together. Position tags out of the way during cleaning, inspection, and repair. Mark tags with a pencil, pen, or marker.
2. Whenever possible, identify electrical wires with the number of the terminal or wire to which it connects. If no markings can be found, tag both wires or wire and terminal, and use the same identifying mark for both. If you cannot tag a wire because it must fit through a small hole or you cannot reach it, write down the description of the wire and the point to which it connects or draw a simple diagram on paper. Be sure to write down enough information so you will be able to properly connect the wires during assembly. If you need to identify a loose wire, look for identifying number near end of the wire, stamped on a permanent metal tag. Compare the number to wire numbers on the appropriate electrical schematic.
3. Identify and tag other parts as required by name and installed location.

END OF WORK PACKAGE

THIS WORK PACKAGE COVERS

Leak Test, Recovery, Evacuation, Charging

INITIAL SETUP**Maintenance Level**

Direct Support

Tools and Special Tools

Tool Kit, General Mechanic's (Item 9, WP 0024 00)

Reclaimer, Refrigerant (Item 5, WP 0024 00)

Tool Kit, Refrigeration Equipment (Item 10, WP 0024 00)

Materials/Parts

Oil, Lubricating, Refrigerant Compressor (Item 8, WP 0025 00)

Rag, Wiping (Item 9, WP 0025 00)

Refrigerant, (4V886) R-134a (Item 10, WP 0025 00)

Personnel Required

Two

References

WP 0004 00

Equipment Conditions**(M915A1P1)**

Vehicle parked on level ground (TM 9-2320-283-10)

Parking/Emergency Brake applied (TM 9-2320-283-10)

Engine OFF (TM 9-2320-283-10)

Ignition Key Switch in OFF position (TM 9-2320-283-10)

(M915P1, M916P1, M917P1, and M920P1)

Vehicle parked on level ground (TM 9-2320-273-10)

Parking/Emergency Brake applied (TM 9-2320-273-10)

Engine OFF (TM 9-2320-273-10)

Ignition Key Switch in OFF position (TM 9-2320-273-10)

**WARNING**

- Contact with refrigerant can cause frostbite. Keep hands and face away to prevent personal injury.
- Protective face shield must always be worn when refrigerant lines are opened, even if the gauges indicate the system is empty.
- Always use caution if a fitting is removed. Slowly loosen the fitting. If the system is still under any pressure, release it slowly in a well-ventilated area.
- DO NOT smoke when servicing A/C or wherever refrigerant gas may be present.
- Failure to follow these warnings may result in injury or death to personnel.

NOTE

Replace receiver/dryer if one or more of the following conditions occurs before you purge A/C system:

- A/C system has been previously opened for service.
- Too much air or moisture in A/C system, indicated by low refrigerant.
- Receiver/dryer has been operated for 2 or more years.
- A/C system opened for longer than 5 minutes.
- Large A/C system leak (break in hose or line).

LEAK TEST**NOTE**

- If service work is required on an A/C system, the refrigerant must be recovered first before components are removed.
 - The A/C system must contain at least 0.88 lb (0.4 kg) of refrigerant. The manifold gauge set can determine if pressure exists in the system.
 - Leaks that are in the high side of the A/C system are more easily found if the A/C is operated for 5 to 10 minutes. The leak test must be performed immediately after the unit is turned off. The leak test for the high side needs to be performed before the pressure in the A/C system equalizes.
 - Leaks that are in the low side of the A/C system are more easily found if the A/C has been shut off for 5 to 10 minutes. The leak test for the low side needs to be performed before the pressure in the A/C system equalizes.
1. Move leak detector sensor tip along possible leak points, at a rate of 1 in. per second.
 2. Leak detector will indicate if leak is present in A/C system.

RECOVERY**NOTE**

- Refrigerant identifier will prevent other refrigerants from contaminating R-134a recovery and charging tools. Refrigerant identifier will also detect a percentage of air that may be in the A/C system.
 - If service is required on the A/C system, refrigerant must be recovered before A/C system components are removed. Use the following procedure:
1. Use refrigerant identifier to ensure refrigerant in A/C system is R-134a.
 2. Make sure both manifold gauge set (1) valves (2 and 3) are closed. Turn valves clockwise to close.
 3. Connect manifold gauge set (1) low-side hose (4) to suction (low) side of A/C compressor.
 4. Connect manifold gauge set (1) high-side hose (5) to discharge (high) side of A/C compressor.
 5. Attach charging hose (6) to recovery station inlet (7).

NOTE

One valve is for vapor and the other valve is for liquid.

6. Ensure valves on refrigerant recovery tank (8) are open.

RECOVERY - CONTINUED

Follow recovery station OEM instructions and recover R-134a refrigerant.

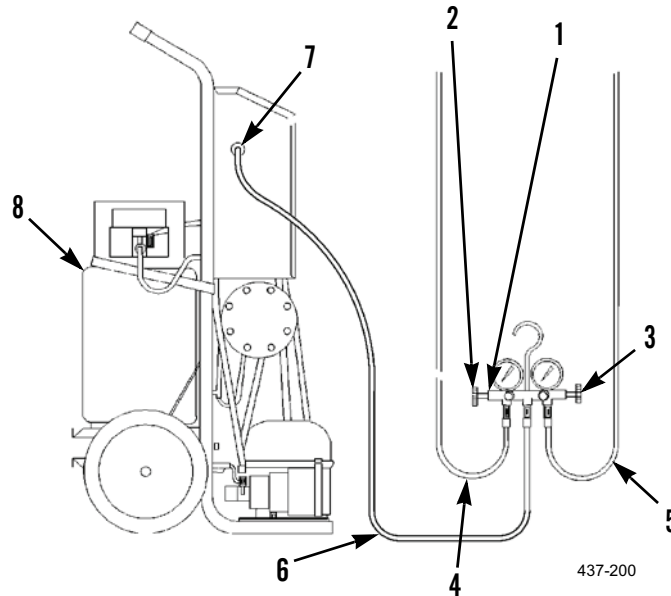
**EVACUATION****CAUTION**

- Moisture will combine with metals in the refrigerant system and this will produce highly corrosive by-products. The by-products are oxides, iron hydroxide, and aluminum hydroxide and they will damage the A/C system.
- Moisture in the A/C system can freeze and damage the expansion valve and orifice tube. If there is water in the system, the water must be removed by evacuation.
- Failure to follow these cautions could cause equipment damage.

NOTE

- If replacement or repair of a component is necessary, refrigerant must be recovered from A/C system.
- If A/C system has lost any charge after a long period of time, refrigerant in A/C system must be recovered.
- It is necessary to perform evacuating procedure to remove all air and moisture from the A/C system.
- A complete charge must never be given to a system without first performing the evacuating procedure.
- If the system has been left open for more than a half hour, the system has been exposed to air and moisture. A new receiver/dryer must be installed.
- Evacuating the A/C system with a vacuum pump will boil and remove any water in the system. Remove water from the A/C system by evacuating the system with a vacuum pump.

EVACUATION - CONTINUED

1. Ensure manifold gauge set (1) valves (2 and 3) are closed.
2. Disconnect charging hose (6) from recovery station inlet (7) on refrigerant service unit.
3. Check oil level in vacuum pump. Add oil as necessary. Refer to vacuum pump OEM manual for correct procedure.
4. Connect charging hose (6) to inlet (9) on vacuum pump.
5. Open both manifold gauge set (1) valves (2 and 3) completely. Turn valves counterclockwise to open.
6. Evacuate A/C system. Refer to vacuum pump OEM manual for operation instructions.

NOTE

At high elevations, less vacuum is required. 28 inHg to 29 inHg (95 kPa to 98 kPa) is the required specification at sea level. For every 1,000 ft (305 m) above sea level, decrease the required specification by 1 inHg (3 kPa).

Ambient Temperature °F (°C)	Vacuum Required to Boil Water in A/C System inHg (kPa)
100°F (38°C)	28 inHg (95 kPa)
90°F (32°C)	28.5 inHg (96.5 kPa)
81°F (27°C)	28.8 inHg (97.5 kPa)
70°F (21°C)	29.2 inHg (98.8 kPa)

7. Operate vacuum pump until low pressure gauge (10) indicates a vacuum between 28 inHg to 29 inHg (95 kPa to 98 kPa).
8. After vacuum in A/C system reaches between 28 inHg to 29 inHg (95 kPa to 98 kPa), operate vacuum pump for a minimum of 90 minutes.

NOTE

The evacuating procedure removes air and moisture from the system. Do not use the vacuum pump primarily to indicate a system leak.

9. If specific vacuum cannot be reached, A/C system may have a leak. Repair all leaks and repeat steps 1 through 8.
10. After 28 inHg to 29 inHg (95 kPa to 98 kPa) vacuum has been reached and held for an additional 90 minutes, close manifold gauge set (1) valves (2 and 3) completely.
11. Turn OFF vacuum pump. Refer to vacuum pump OEM manual for operation instructions.

EVACUATION - CONTINUED

NOTE

- Excessive vacuum loss is an indication of a possible leak in the system.
- The maximum amount of vacuum loss in 5 minutes must not be more than 2 inHg (7 kPa). Repair all leaks and repeat steps 1 through 11.

12. If vacuum loss does not exceed 2 inHg (7 kPa) in 5 minutes, system is ready to charge.

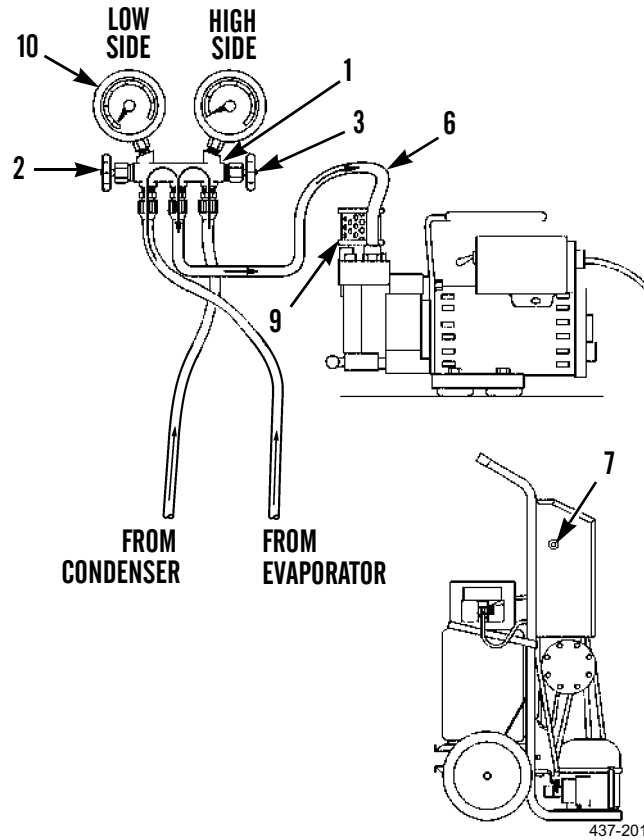

CHARGING**CAUTION**

DO NOT charge the A/C system with liquid refrigerant through the compressor suction ports. This could seriously damage the compressor.

NOTE

- Charging should be performed at air temperatures of 70°F (21°C) and above. Changes in ambient air temperature will affect the system's ability to take a charge and will vary gauge readings.
 - When adding a partial charge to the A/C system, if there is no evidence of air in the system and there are no system leaks, it is not necessary to discharge and evacuate the A/C system.
 - Operating A/C system periodically during the off-season will lubricate the seals and reduce the possibility of refrigerant loss.
 - Up to 7 oz. (200 g) of refrigerant loss per year is considered normal.
 - Steps 1 through 3 only need to be performed if a partial charge is being done.
1. Connect manifold gauge set (1) low-side hose (4) to suction (low) side of A/C compressor.
 2. Connect manifold gauge set (1) high-side hose (5) to discharge (high) side of A/C compressor.

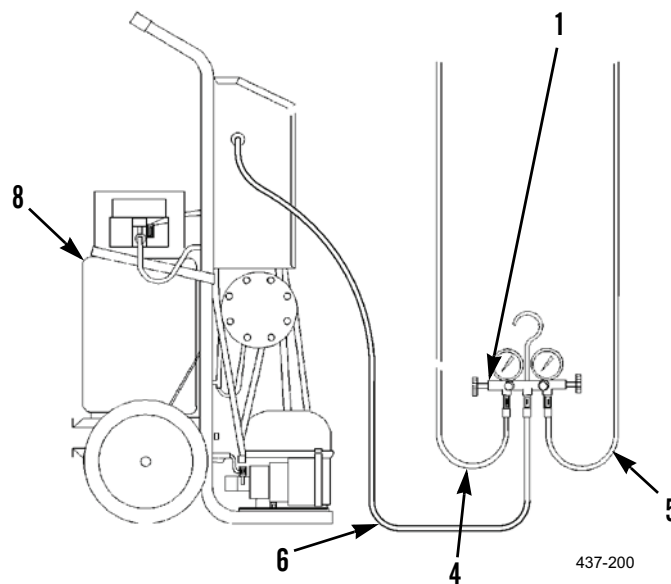

CHARGING - CONTINUED**WARNING**

Only service refrigerant in a well-ventilated area. Personal injury or death can result from inhaling refrigerant.

3. Connect charging hose (6) to R-134a refrigerant tank valve (11).

CAUTION

DO NOT invert the R-134a refrigerant tank while charging the system. Liquid refrigerant entering the low side of the A/C system will permanently damage the compressor.

4. Ensure R-134a refrigerant tank (12) stands upright vertically, to ensure only refrigerant vapor can be charged into A/C system.
5. Open refrigerant tank valve (11) on R-134a refrigerant tank (12).
6. Start engine (TM 9-2320-273-10 and TM 9-2320-283-10).
7. Set A/C controls to HIGH COOL (WP 0004 00).

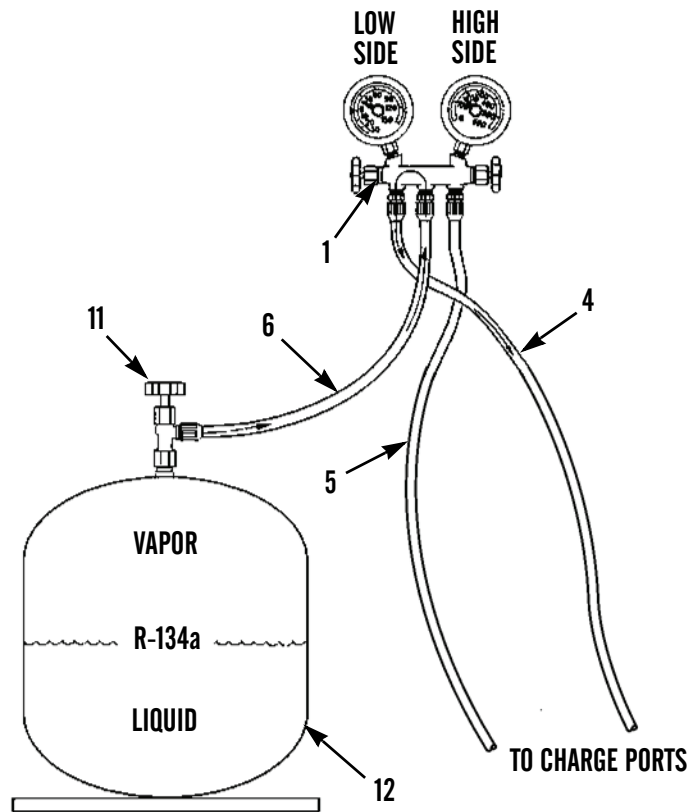

437-202

CHARGING - CONTINUED**NOTE**

Keep high-side valve closed on manifold gauge set while charging the A/C system.

8. Slowly open low-side valve (2) on manifold gauge set (1).
9. Continue charging until bubbles disappear from receiver/dryer sight glass and high-side/low-side pressures are within acceptable range.
10. Close refrigerant tank valve (11) on R-134a refrigerant tank (12).
11. Close low-side valve (2) on manifold gauge set (1).
12. Shut off engine (TM 9-2320-273-10 and TM 9-2320-283-10).
13. Disconnect charging hose (6) from R-134a refrigerant tank valve (11).
14. Disconnect manifold gauge set (1) from A/C compressor.
15. Operate A/C system to verify correct operation (WP 0004 00).

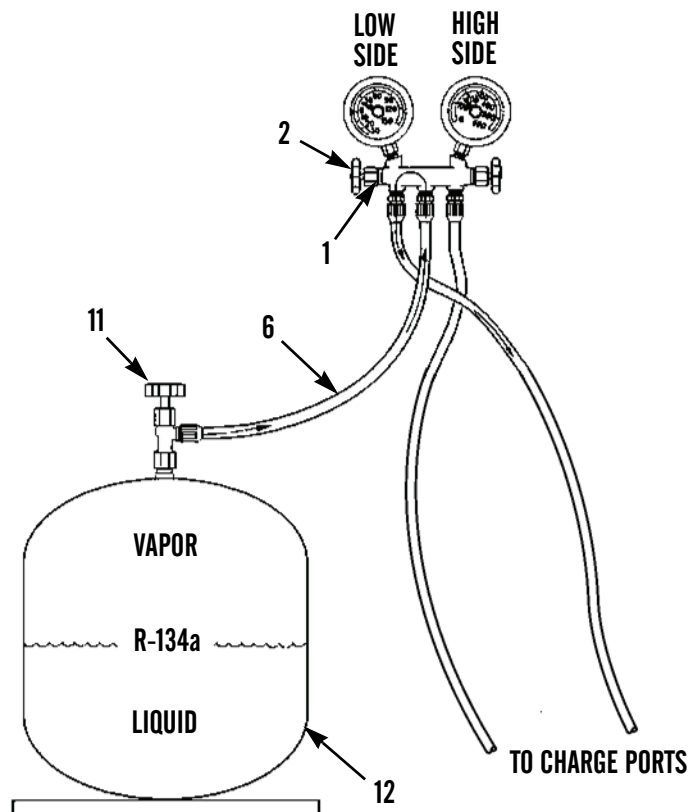

437-202

CHARGING - CONTINUED

Table 1. A/C Sight Glass Check.

Sight Glass Appearance	Refrigerant Condition	Action Required
No Liquid. 	No refrigerant charge.	a. Charge the system with R-134a refrigerant. b. Ensure shut off valves are open. c. Ensure receiver/dryer is not blocked.
Clear liquid or some bubbles appear only during cooling modes. 	Good refrigerant charge.	System is normal.
Bubbles in stream. 	Refrigerant charge is low.	System requires refrigerant charge.

Table 2. High-Side/Low-Side Gauge Pressures at Ambient Temperature Cross-Reference.

Ambient Temperature °F (°C)	High-Side Pressure psi (kPa)	Low-Side Pressure psi (kPa)
61°F (16°C)	123 to 174 psi (850 to 1,200 kPa)	3 to 15 psi (20 to 100 kPa)
70°F (2 °C)	152 to 254 psi (1,050 to 1,750 kPa)	3 to 15 psi (20 to 100 kPa)
81°F (27°C)	181 to 276 psi (1,250 to 1,900 kPa)	3 to 15 psi (20 to 100 kPa)
90°F (32°C)	203 to 312 psi (1,400 to 2,150 kPa)	4 to 22 psi (30 to 150 kPa)
100°F (38°C)	232 to 334 psi (1,600 to 2,300 kPa)	4 to 29 psi (30 to 200 kPa)
109°F (43°C)	276 to 363 psi (1,900 to 2,500 kPa)	4 to 36 psi (30 to 250 kPa)

END OF WORK PACKAGE

COMPRESSOR REPLACEMENT

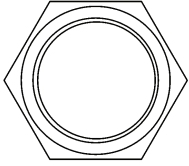
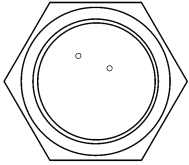
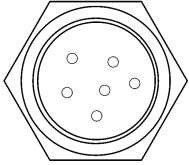
0016 00

THIS WORK PACKAGE COVERS

Removal, Cleaning and Inspection, Installation

INITIAL SETUP

Maintenance Level

Direct Support

Tools and Special Tools

Tool Kit, General Mechanic's (Item 9, WP 0024 00)

Shop Equipment, Common No. 1 (Item 6, WP 0024 00)

Reclaimer, Refrigerant (Item 5, WP 0024 00)

Tool Kit, Refrigeration Equipment (Item 10, WP 0024 00)

Materials/Parts

Oil, Lubricating, Refrigerant Compressor (Item 8, WP 0025 00)

Rag, Wiping (Item 9, WP 0025 00)

Refrigerant, (4V886) R-134a (Item 10, WP 0025 00)

Locknut (7)

Lockwasher (8)

O-ring (6)

References

WP 0014 00

Equipment Conditions

(M915A1P1)

Vehicle parked on level ground (TM 9-2320-283-10)

Parking/Emergency Brake applied (TM 9-2320-283-10)

Engine OFF (TM 9-2320-283-10)

Ignition Key Switch in OFF position (TM 9-2320-283-10)

A/C Refrigerant recovered (WP 0015 00)

(M915P1, M916P1, M917P1, and M920P1)

Vehicle parked on level ground (TM 9-2320-273-10)

Parking/Emergency Brake applied (TM 9-2320-273-10)

Engine OFF (TM 9-2320-273-10)

Ignition Key Switch in OFF position (TM 9-2320-273-10)

A/C Refrigerant recovered (WP 0015 00)

**WARNING**

- Contact with refrigerant can cause frostbite. Keep hands and face away to prevent personal injury.
- Protective face shield must always be worn when refrigerant lines are opened, even if the gauges indicate the system is empty.
- Always use caution if a fitting is removed. Slowly loosen the fitting. If the system is still under any pressure, release it slowly in a well-ventilated area.
- DO NOT smoke when servicing A/C or wherever refrigerant gas may be present.
- Failure to follow these warnings may result in injury or death to personnel.

CAUTION

Cap all A/C hose ends and component connections during removal to protect against contamination. Failure to comply may cause damage to equipment.

REMOVAL**NOTE**

Tag wires and hoses to aid in installation.

1. Disconnect wiring harness connector (5) from compressor (7).
2. Disconnect A/C hose (4) from compressor (7).
3. Disconnect A/C hose (6) from compressor (7).
4. Loosen four bolts (1) and locknuts (3) on compressor (7).
5. Slide compressor (7) down on compressor mounting bracket (9) to loosen drive belt (8).

NOTE

Record which groove drive belt is mounted in on compressor to aid installation.

6. Remove drive belt (8) from compressor (7).

NOTE

Compressor mounting bolts are metric.

7. Remove four locknuts (3), bolts (1), and washers (2) from compressor (7). Discard locknuts.
8. Remove compressor (7) from compressor mounting bracket (9).

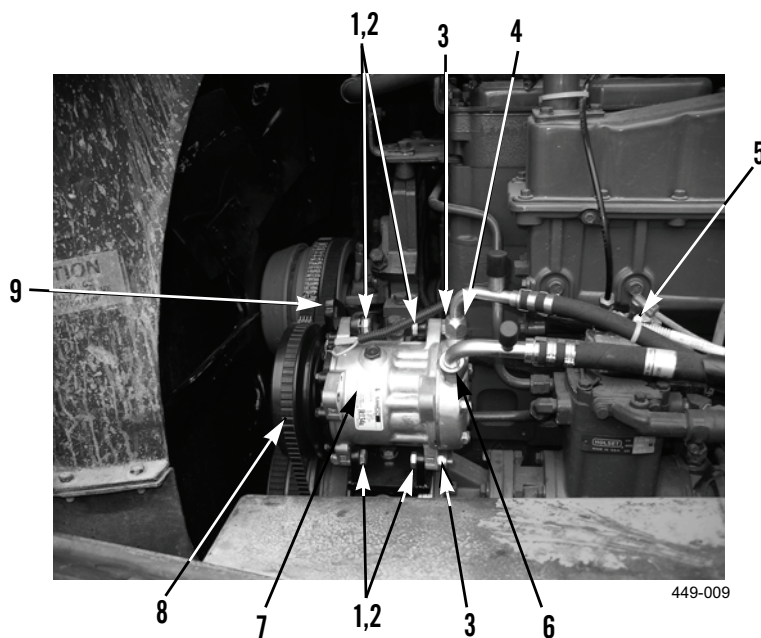

COMPRESSOR REPLACEMENT - CONTINUED

0016 00

REMOVAL - CONTINUED

9. Remove three locknuts (12), washers (11), and bolts (10) from mounting bracket (9). Discard locknuts.
10. Remove compressor mounting bracket (9) from vehicle.

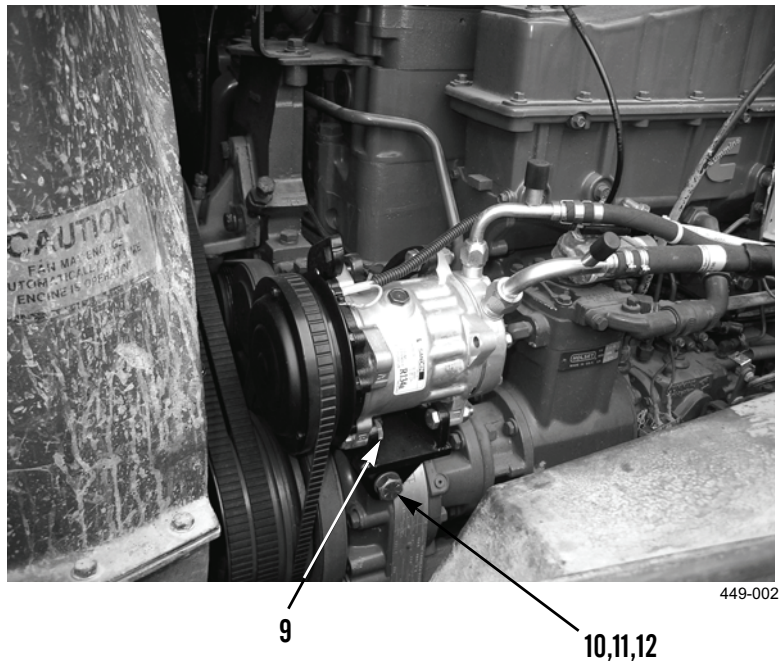
**CLEANING AND INSPECTION**

Clean and inspect all parts IAW *General Maintenance Instructions* (WP 0014 00).

INSTALLATION

1. Install compressor mounting bracket (9), three bolts (10), washers (11), and new locknuts (12) on vehicle. Tighten to 35 lb-ft (47.5 Nm).
2. Install compressor (7) on compressor mounting bracket (2).

NOTE

Leave bolts loose enough so that compressor can slide on mounting bracket.

3. Loosely install four washers (2), bolts (1), and new locknuts (3).

NOTE

Install drive belt in pulley groove noted in removal.

4. Install drive belt (8) on compressor (7).

INSTALLATION - CONTINUED**NOTE**

- Belt tension gage indication should be 120 lb (534 N) for new belts and 90 lb (400 N) for used belts.
- Belts are considered used if they have more than 30 minutes of operation.
- Make sure compressor does not tilt during belt tensioning.

5. Using breaker bar, adjust drive belt (8) tension.
6. Tighten four bolts (1) and locknuts (3) to 35 lb-ft (47.5 Nm).
7. Check drive belt (8) tension and adjust as required.

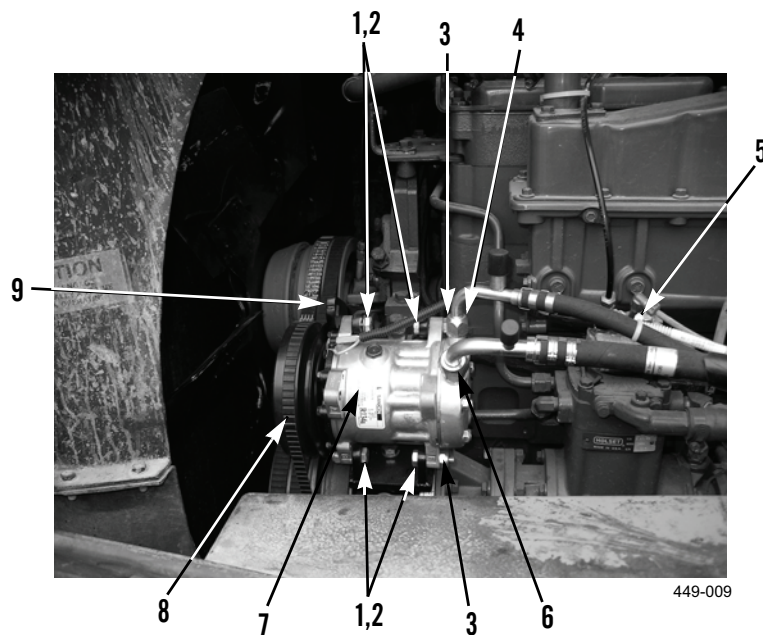
**NOTE**

Install wires and hoses as tagged during removal.

8. Apply refrigerant oil to new O-ring and install A/C hose (6) on compressor (7).
9. Apply refrigerant oil to new O-ring and install A/C hose (4) on compressor (7).
10. Connect wiring harness connector (5) to compressor (7).
11. Evacuate and recharge A/C system (WP 0015 00).

END OF WORK PACKAGE

EVAPORATOR ASSEMBLY MAINTENANCE

0017 00

THIS WORK PACKAGE COVERS

Removal, Disassembly, Cleaning and Inspection, Assembly, Installation

INITIAL SETUP

Maintenance Level

Direct Support

Tools and Special Tools

Tool Kit, General Mechanic's (Item 9, WP 0024 00)

Shop Equipment, Common No. 1 (Item 6, WP 0024 00)

Tool Kit, Refrigeration Equipment (Item 10, WP 0024 00)

Materials/Parts

Oil, Lubricating, Refrigerant Compressor (Item 8, WP 0025 00)

Rag, Wiping (Item 9, WP 0025 00)

Strap, Tiedown (Item 12, WP 0025 00)

Tag, Marker (Item 13, WP 0025 00)

Tape, Refrigeration (Item 15, WP 0025 00)

Locknut (6)

Lockwasher (1)

O-ring (2)

Personnel Required

Two

References

WP 0004 00

WP 0014 00

Equipment Conditions

(M915A1P1)

Vehicle parked on level ground (TM 9-2320-283-10)

Parking/Emergency Brake applied (TM 9-2320-283-10)

Engine OFF (TM 9-2320-283-10)

Ignition Key Switch in OFF position (TM 9-2320-283-10)

Air Filter removed (WP 0010 00)

A/C Refrigerant recovered (WP 0015 00)

(M915P1, M916P1, M917P1, and M920P1)

Vehicle parked on level ground (TM 9-2320-273-10)

Parking/Emergency Brake applied (TM 9-2320-273-10)

Engine OFF (TM 9-2320-273-10)

Ignition Key Switch in OFF position (TM 9-2320-273-10)

Air Filter removed (WP 0010 00)

A/C Refrigerant recovered (WP 0015 00)

REMOVAL**NOTE**

Tag wires and hoses to aid in installation.

1. Remove bolt (2), washer (3), and P-clamp (4) from evaporator assembly (1).
2. Remove bolt (6), washer (7), and access cover (5) from evaporator assembly (1).

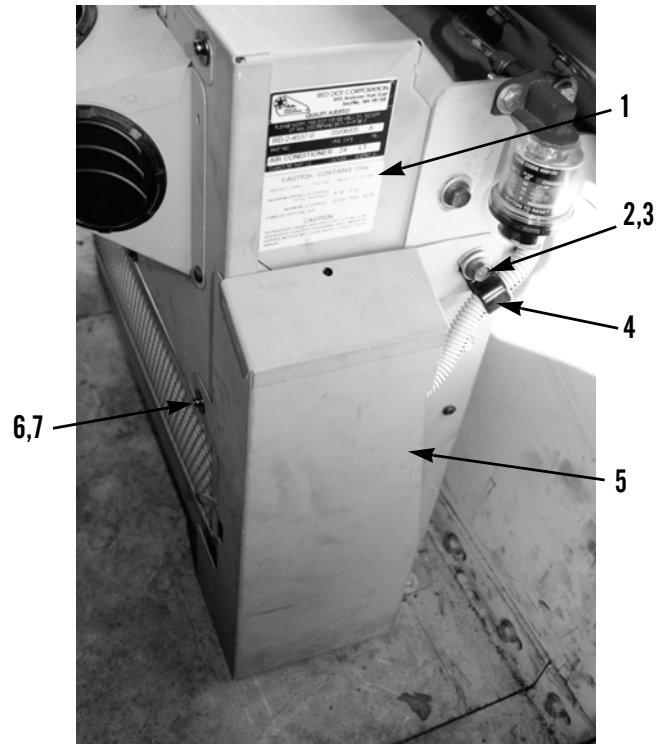

449-020

**WARNING**

- Contact with refrigerant can cause frostbite. Keep hands and face away to prevent personal injury.
- Protective face shield must always be worn when refrigerant lines are opened, even if the gauges indicate the system is empty.
- Always use caution if a fitting is removed. Slowly loosen the fitting. If the system is still under any pressure, release it slowly in a well-ventilated area.
- DO NOT smoke when servicing A/C or wherever refrigerant gas may be present.
- Failure to follow these warnings may result in injury or death to personnel.

CAUTION

Cap all A/C hose ends and component connections during removal to protect against contamination. Failure to comply may cause damage to equipment.

NOTE

Tag wires and hoses to aid in installation.

EVAPORATOR ASSEMBLY MAINTENANCE - CONTINUED

0017 00

REMOVAL - CONTINUED

3. Remove A/C hose connection (24) from evaporator assembly (1). Discard O-rings.
4. Remove A/C hose connection (25) from evaporator assembly (1). Discard O-rings.
5. Disconnect wiring harness connector (28) from evaporator assembly (1).
6. Disconnect receiver/dryer wiring harness connector (27) from evaporator assembly (1).
7. Disconnect power and ground harness connector (26) from evaporator assembly (1).
8. Remove tiedown strap as required. Discard tiedown strap.
9. Remove two locknuts (10), bolts (8), washers (9), and air filter gauge (11) from evaporator assembly (1). Discard locknuts.
10. Remove bolt (16), washer (17), locknut (14), bolt (12), washer (13), and upper evaporator assembly bracket (15) from evaporator assembly (1). Discard locknut.
11. Remove two bolts (18), locknut (23), washer (22), bolt (20), washer (21), and lower evaporator assembly bracket (19) from evaporator assembly (1). Discard locknut.

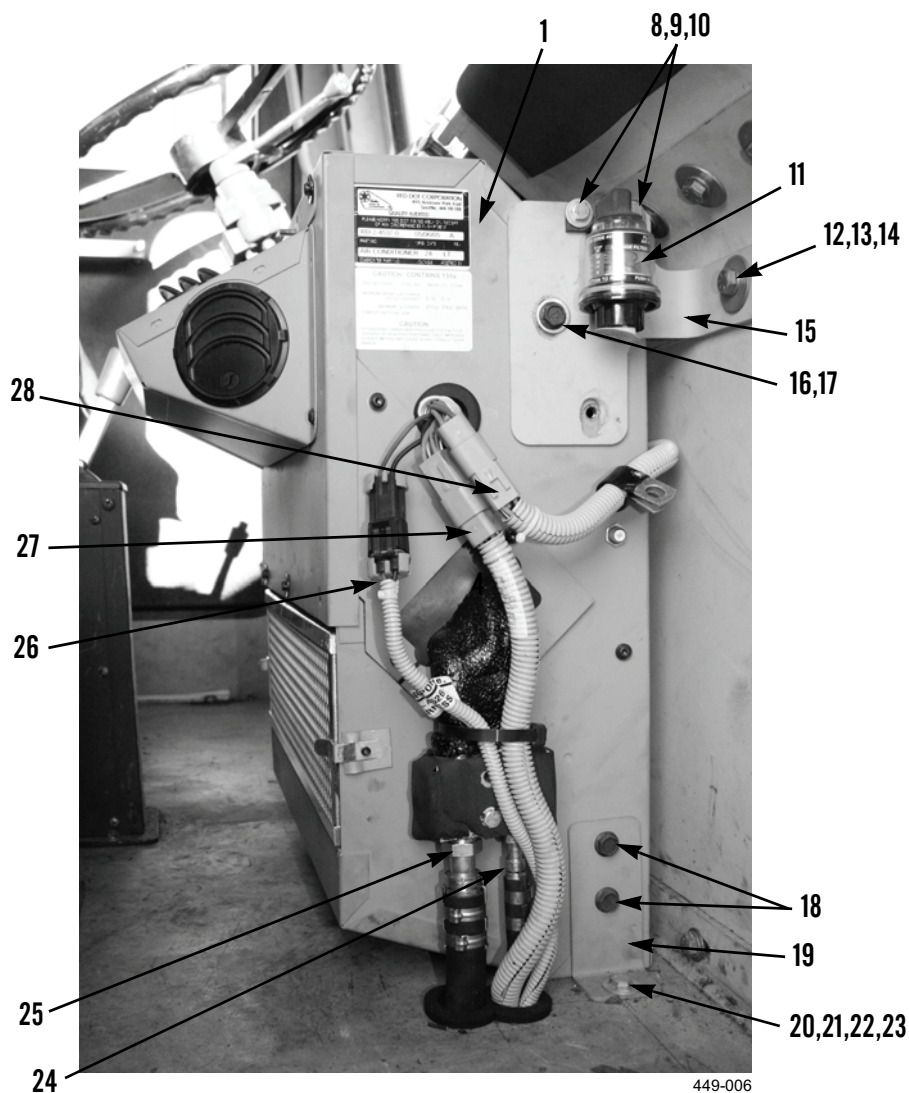

EVAPORATOR ASSEMBLY MAINTENANCE - CONTINUED

0017 00

REMOVAL - CONTINUED

12. Loosen four fasteners (29) and open instrument panel (30).

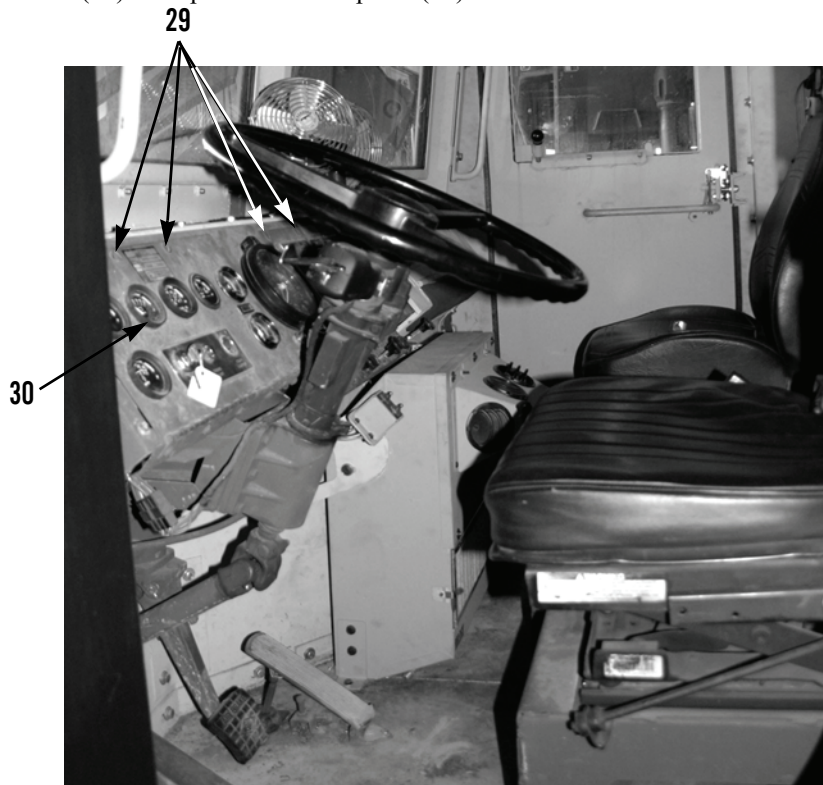

449-017

NOTE

Tag wires and hoses to aid in installation.

13. Disconnect ignition wire (31) (white wire) from ignition switch (32).

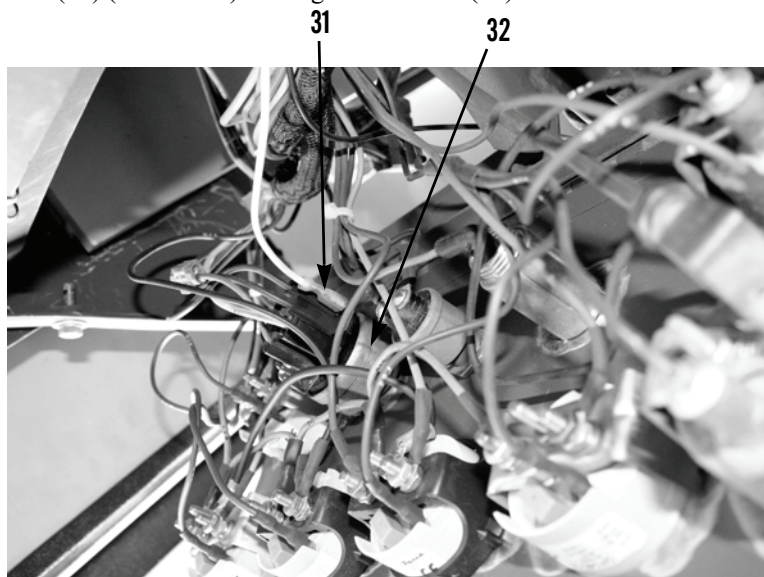

449-018

REMOVAL - CONTINUED**NOTE**

Tag wires and hoses to aid in installation.

14. Remove four screws (34) and A/C switch box (33) from upper evaporator assembly bracket (41).
15. Disconnect compressor clutch connector (42) (black with white stripe) from compressor wire through firewall and remove wiring harness with A/C switch box (33) from vehicle.
16. Remove two bolts (35), washers (36), locknut (40), washer (39), bolt (37), washer (38), and upper evaporator assembly bracket (41) from evaporator assembly (1). Discard locknut.

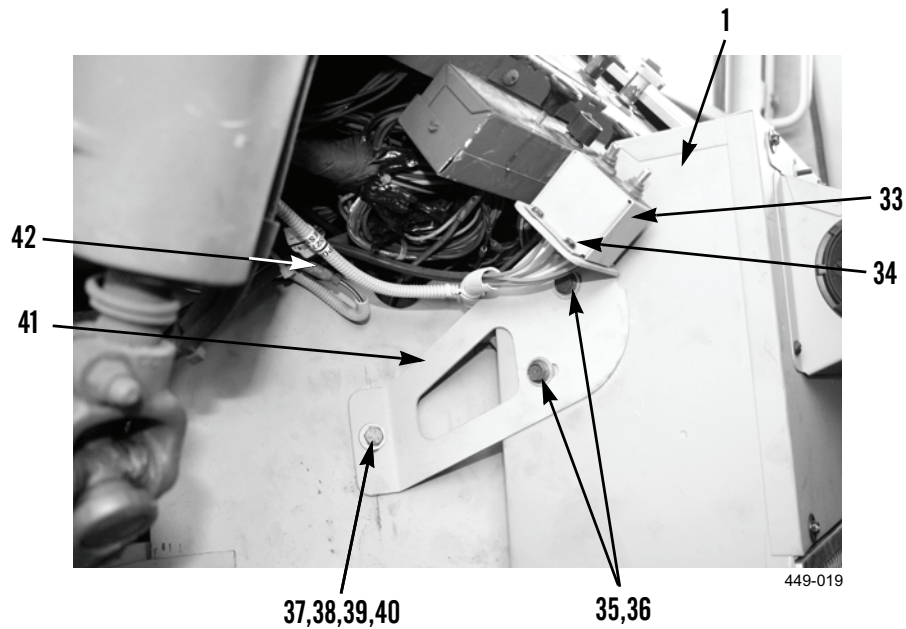

EVAPORATOR ASSEMBLY MAINTENANCE - CONTINUED

0017 00

REMOVAL - CONTINUED

17. Remove two bolts (47), locknut (46), washer (45), bolt (43), washer (44), lower evaporator assembly bracket (48) from evaporator assembly (1). Discard locknut.

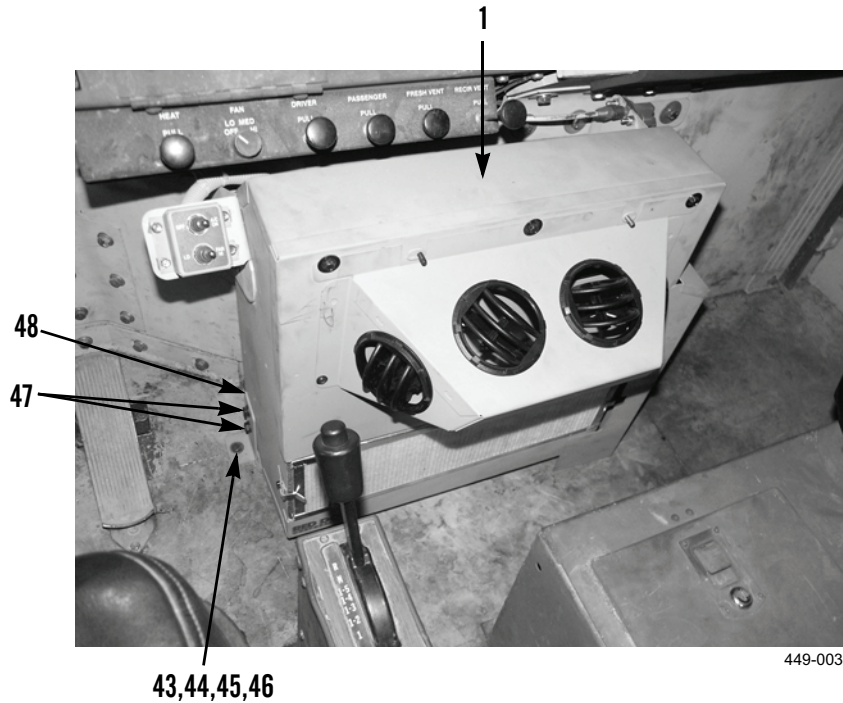
**WARNING**

Evaporator assembly weighs approximately 40 lb (18 kg). Use caution when handling heavy parts. Provide adequate support and use assistance during procedure. Failure to follow this warning may cause injury to personnel.

NOTE

Tag wires and hoses to aid in installation.

EVAPORATOR ASSEMBLY MAINTENANCE - CONTINUED

0017 00

REMOVAL - CONTINUED

18. With assistance, remove evaporator assembly (1) from vehicle being careful that drain tubes do not catch while removing them from holes in floor.
19. Remove two rubber duck bill grommets (44), plastic couplers (43), nylon tie wraps (41), and drain hoses (42) from evaporator assembly (1).

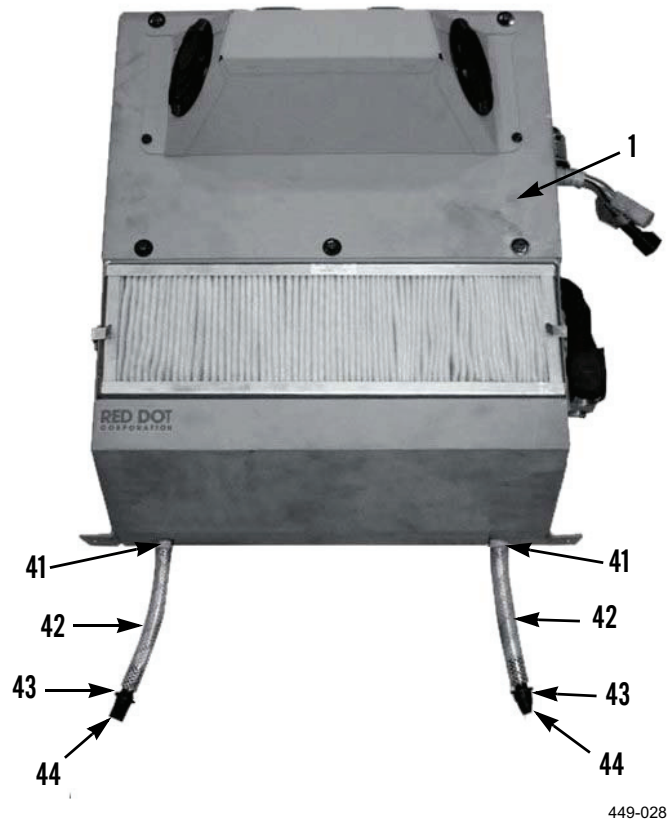

DISASSEMBLY**NOTE**

Tag wires and hoses to aid in installation.

1. Remove two screws (6), washers (7), and plenum assembly (5) from evaporator assembly (1).
2. Remove five bolts (2), washers (3), and carefully open evaporator assembly access cover (4) just enough to access wiring to blower assembly.



449-022

3. Remove black blower motor wire (9), red blower motor wire (10), and resistor speed control connector (8) from blower assembly (11).

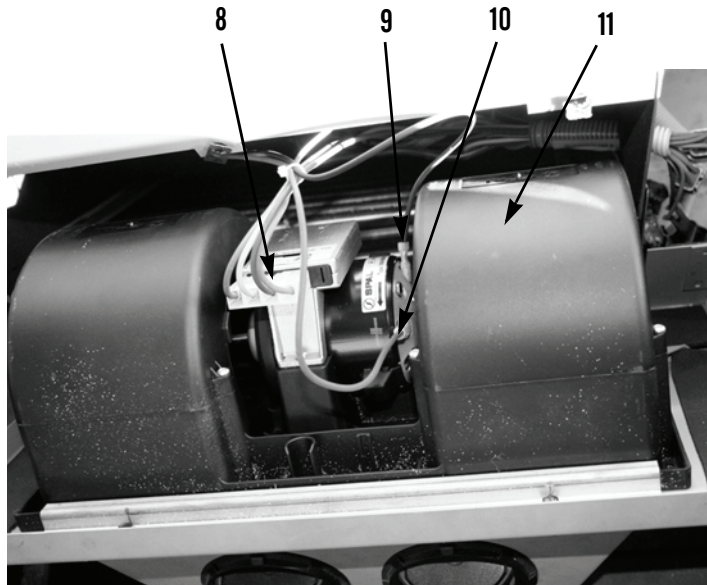

449-023

EVAPORATOR ASSEMBLY MAINTENANCE - CONTINUED

0017 00

DISASSEMBLY - CONTINUED

4. Remove blower assembly (11) and place on flat work surface.
5. Remove two screws (15) and resistor speed control (14) from blower assembly (11).
6. Remove two screws (12), blower mounting strip (13), and blower assembly (11) from evaporator assembly access cover (4).

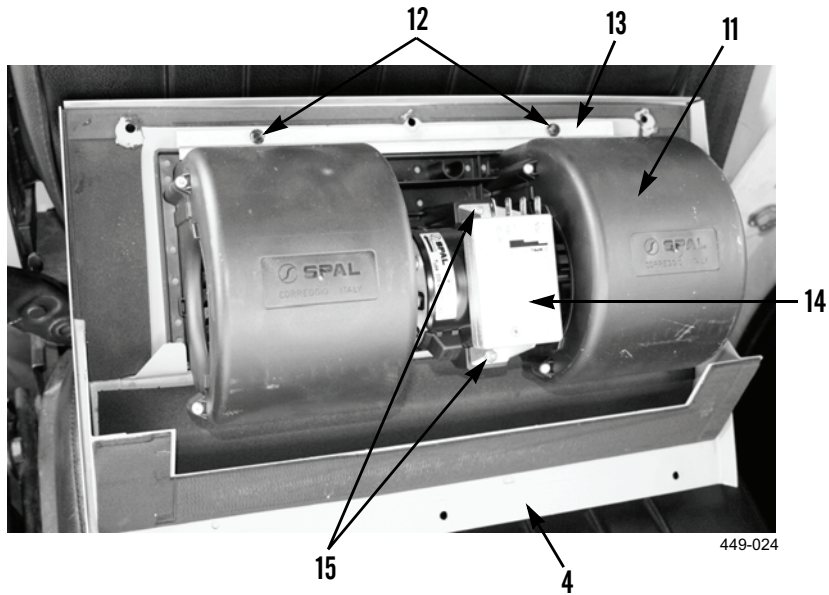

DISASSEMBLY - CONTINUED

NOTE

Tag wires and hoses to aid in installation.

7. Remove insulation tape (18) from hose connection (19) and hose connection (23).
8. Disconnect hose connection (19) and hose connection (23) from expansion valve (22).
9. Remove bolt (20), washer (21), and expansion valve (22) from evaporator assembly (1).
10. Remove five screws (16) and washers (17) from evaporator assembly (1).

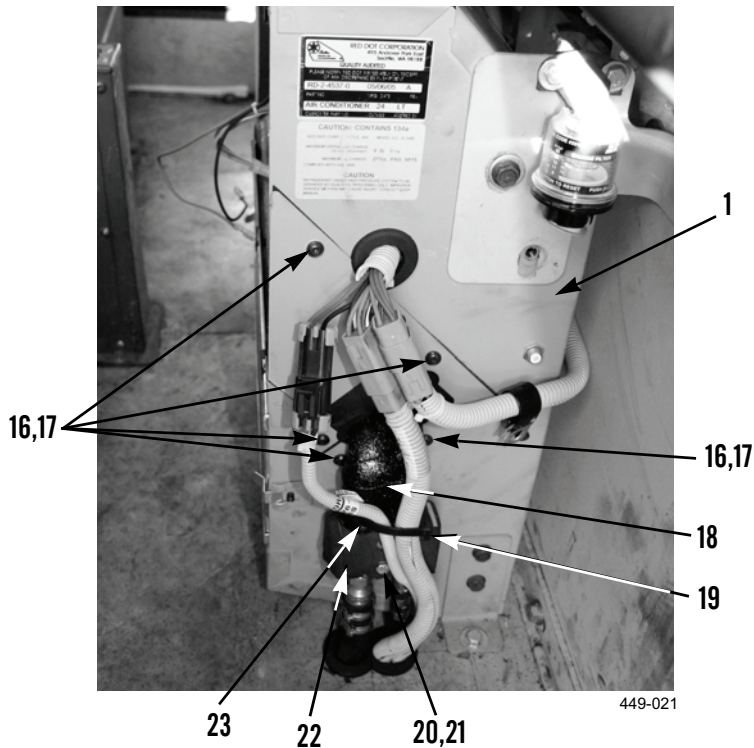

11. Remove thermostat probe (27), evaporator core assembly (26), core side cover (24), and core gasket (25) from evaporator assembly (1).

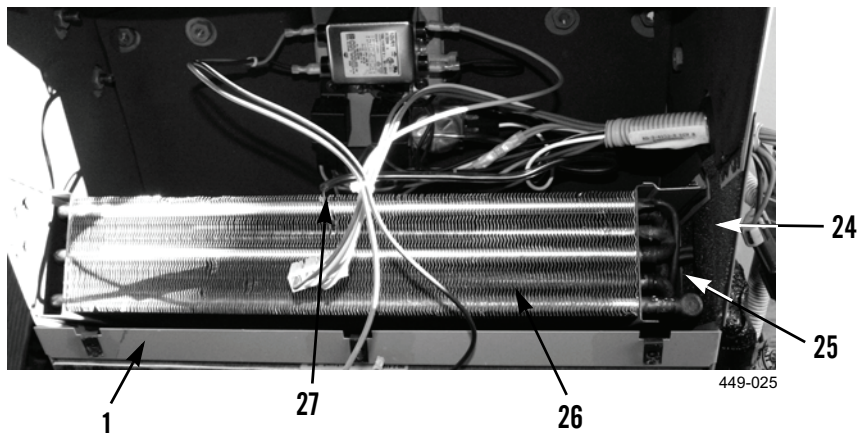

DISASSEMBLY - CONTINUED**NOTE**

Tag wires and hoses to aid in installation.

12. Remove connector (49) (black wire), connector (51) (red wire), connector (30) (orange wire), connector (32) (black wire), and connector (31) (black wire) from EMI filter (50).
13. Remove two screws (28), washers (29), and EMI filter (50) from evaporator assembly (1).
14. Remove connector (35) (black with white stripe wire), connector (36) (white wire), two screws (33), washers (34), and thermostat (37) from evaporator assembly (1).
15. Remove power relay connector (40), screw (38), washer (39), and power relay (41) from evaporator assembly (1).
16. Remove condenser relay connector (45), screw (47), washer (48), and condenser relay (46) from evaporator assembly (1).
17. Remove nut (42), lockwasher (43), and three ground wires (44) (black) from evaporator assembly (1). Discard lock-washer.

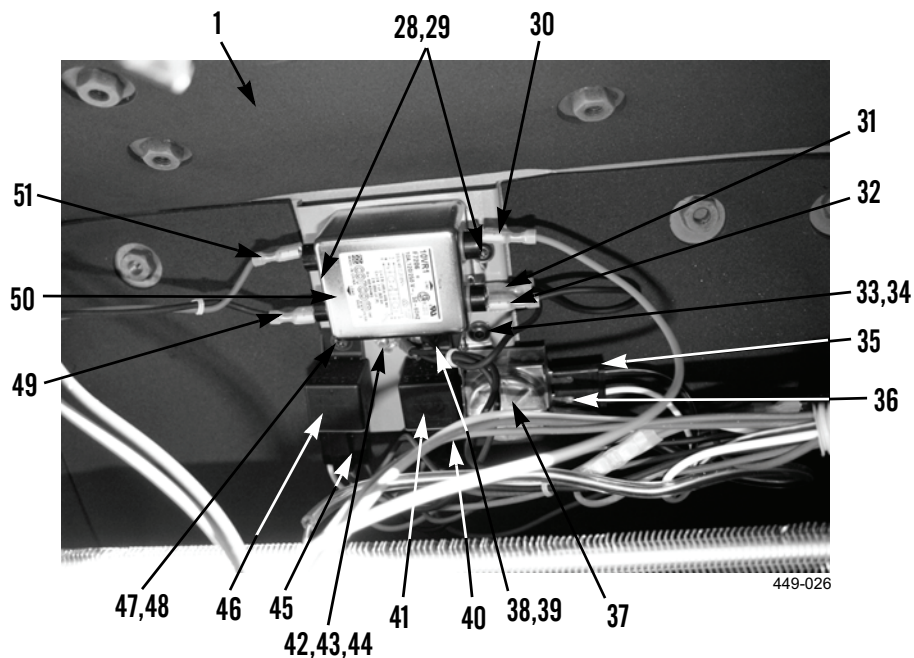

DISASSEMBLY - CONTINUED**NOTE**

Tag wires and hoses to aid in installation.

18. Remove nut (55), connector (52) (red wire), connector (53) (red wire), and circuit breaker (54) from evaporator assembly (1).

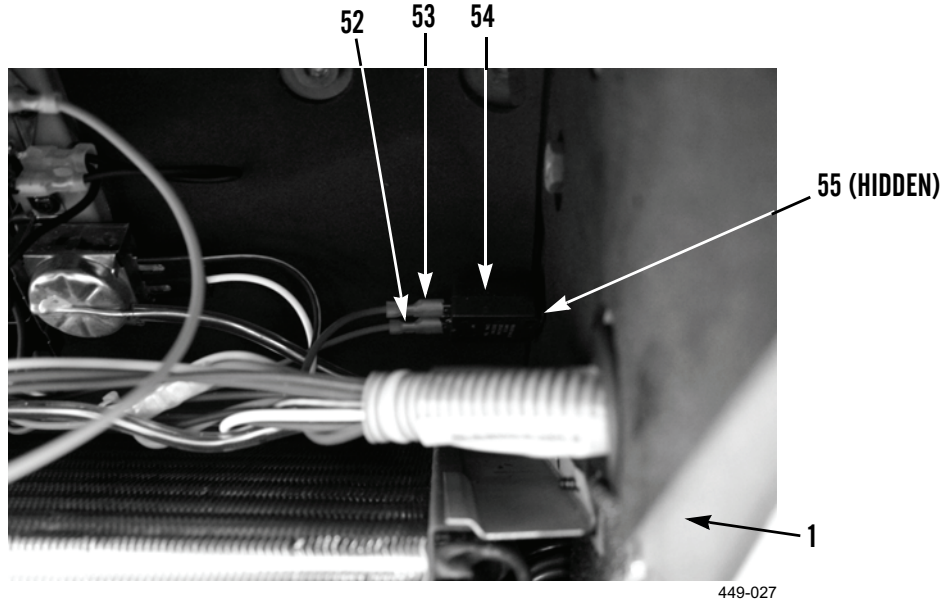
**CLEANING AND INSPECTION**

Clean and inspect all parts IAW *General Maintenance Instructions* (WP 0014 00).

ASSEMBLY**NOTE**

Install wires as tagged during removal.

1. Install circuit breaker (54), connector (53) (red wire), connector (52) (red wire), and nut (55) on evaporator assembly (1).

NOTE

Install wires as tagged during removal.

2. Install three ground wires (44), new lockwasher (43), and nut (42) on evaporator assembly (1).
3. Install condenser relay (46), washer (48), screw (47), and condenser relay connector (45) on evaporator assembly (1).
4. Install power relay (41), washer (39), screw (38), and power relay connector (40) on evaporator assembly (1).
5. Install thermostat (37), two washers (34), screws (33), connector (36) (white wire), and connector (35) (black with white stripe wire) on evaporator assembly (1).
6. Install EMI filter (50), two washers (29), and screws (28) on evaporator assembly (1).
7. Install connector (31) (black wire), connector (32) (black wire), connector (30) (orange wire), connector (51) (red wire), and connector (49) (black wire) on EMI filter (50).

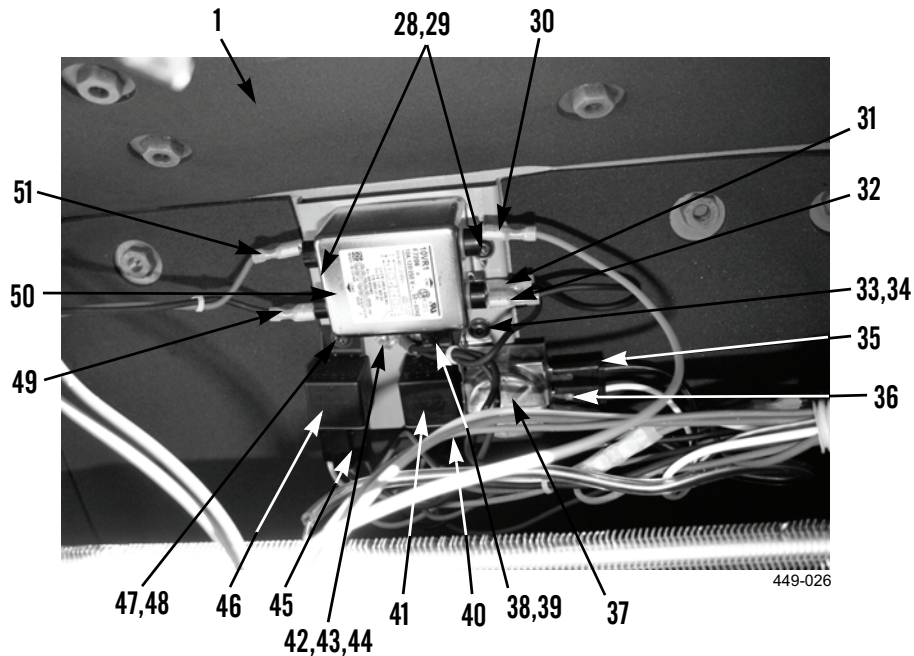

ASSEMBLY - CONTINUED

NOTE

Install wires as tagged during removal.

8. Install core gasket (25), core side cover (24), evaporator core assembly (26), and press thermostat probe (27) into evaporator fins on evaporator assembly (1).

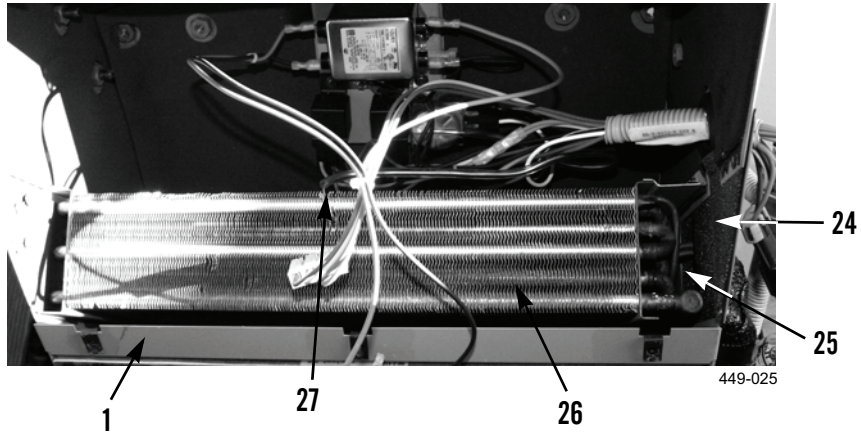

9. Remove insulation tape (18) from hose connection (19) and hose connection (23).
10. Disconnect hose connection (19) and hose connection (23) from expansion valve (22).
11. Remove bolt (20), washer (21), and expansion valve (22) from evaporator assembly (1).
12. Remove five screws (16) and washers (17) from evaporator assembly (1).
13. Install five washers (17) and screws (16) on evaporator assembly (1).
14. Install expansion valve (22), washer (21), and bolt (20) on evaporator assembly (1).
15. Connect hose connection (23) and hose connection (19) on expansion valve (22).

ASSEMBLY - CONTINUED

16. Install insulation tape (18) on hose connection (23) and hose connection (19).

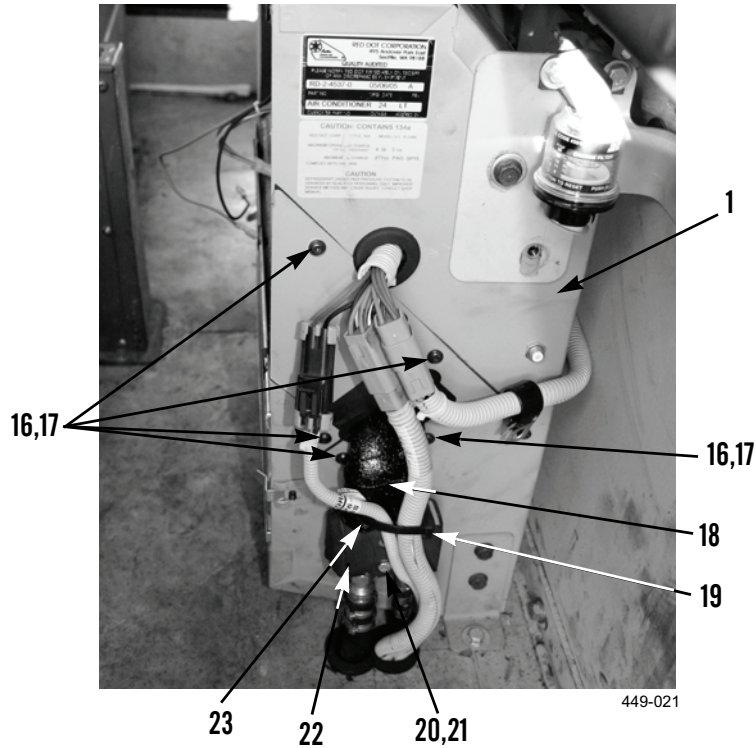

17. Place blower assembly (11) on flat work surface.
18. Install blower assembly (11), blower mounting strip (13), and two screws (12) on evaporator assembly access cover (4).
19. Install resistor speed control (14) and two screws (15) on blower assembly (11).

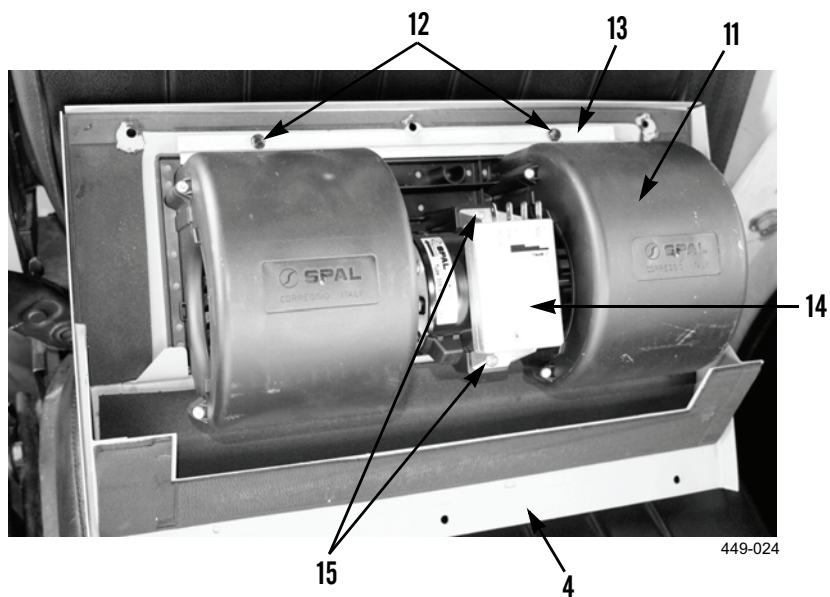

ASSEMBLY - CONTINUED

NOTE

Install wires as tagged during removal.

20. Place blower assembly (11) close enough to connect wiring from evaporator assembly (1).
21. Install resistor speed control connector (8), red blower motor wire (10), and black blower motor wire (9) on blower assembly (11).

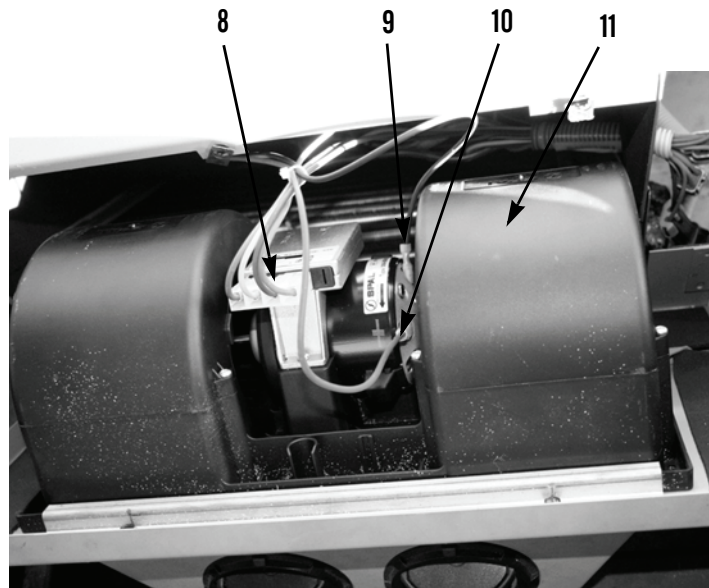

449-023

22. Install evaporator assembly access cover (4), five washers (3), and bolts (2) on evaporator assembly (1).
23. Install plenum assembly (5), two washers (7), and screws (6) on evaporator assembly (1).



449-022

INSTALLATION**WARNING**

Evaporator assembly weighs approximately 40 lb (18 kg). Use caution when handling heavy parts. Provide adequate support and use assistance during procedure. Failure to follow this warning may cause injury to personnel.

NOTE

Install hoses as tagged during removal.

1. Install two drain hoses (42), nylon tie wraps (41), plastic couplers (43), and rubber duck bill grommets (44) on evaporator assembly (1).
2. With assistance, install evaporator assembly (1) on vehicle being careful that drain tubes do not catch while inserting them into holes in floor.



EVAPORATOR ASSEMBLY MAINTENANCE - CONTINUED

0017 00

INSTALLATION - CONTINUED

3. Install two bolts (47), new locknut (46), washer (45), bolt (43), washer (44), and lower evaporator assembly bracket (48) on evaporator assembly (1).

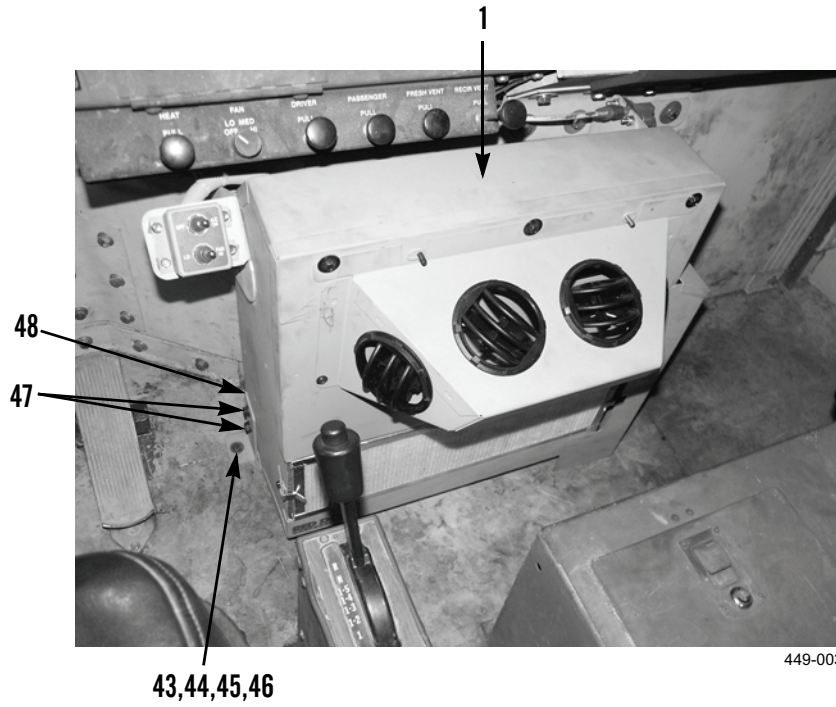

INSTALLATION - CONTINUED**NOTE**

Install wires as tagged during removal.

4. Install upper evaporator assembly bracket (41), washer (38), bolt (37), washer (39), new locknut (40), two washers (36), and bolts (35) on evaporator assembly (1).
5. Install wiring harness with A/C switch box (33) on vehicle and connect compressor clutch connector (42) (black with white stripe) to compressor wire coming through firewall.
6. Install A/C switch box (33) and four screws (34) on upper evaporator assembly bracket (41).

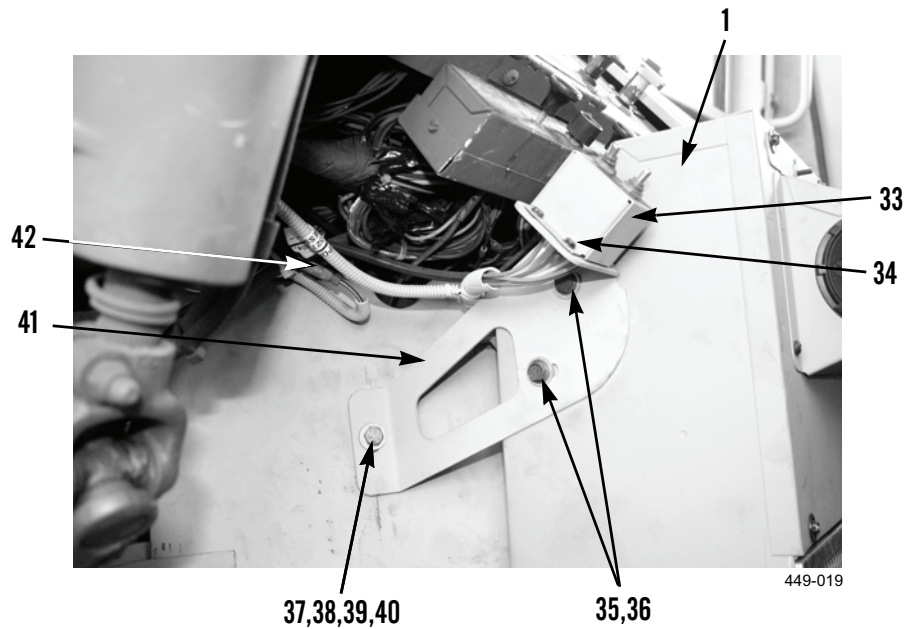

INSTALLATION - CONTINUED**NOTE**

Install wires as tagged during removal.

7. Connect ignition wire (31) (white wire) on ignition switch (32).

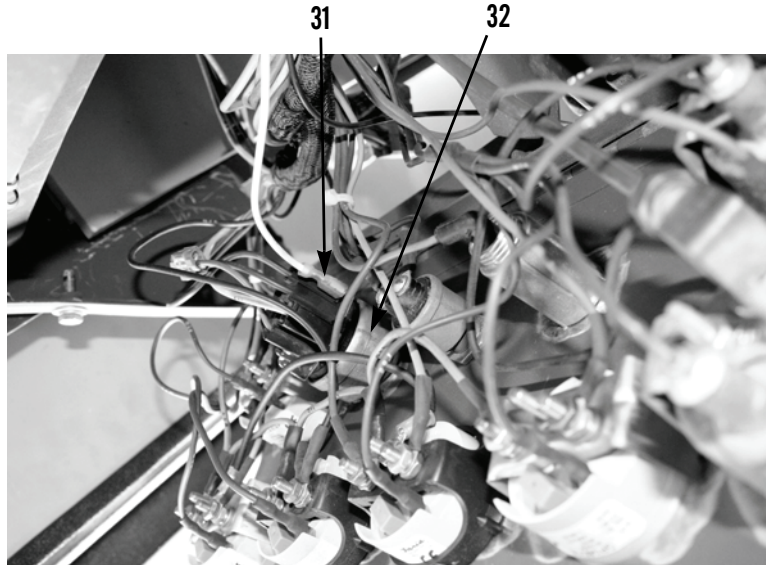

449-018

8. Tighten four fasteners (29) and close instrument panel (30).

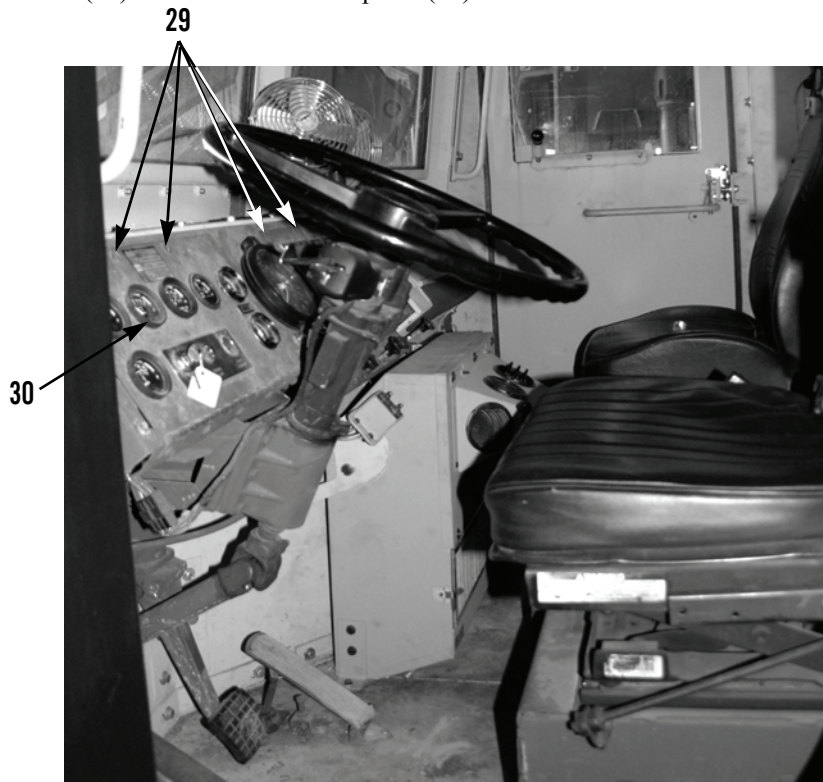

449-017

INSTALLATION - CONTINUED**WARNING**

- Contact with refrigerant can cause frostbite. Keep hands and face away to prevent personal injury.
- Protective face shield must always be worn when refrigerant lines are opened, even if the gauges indicate the system is empty.
- Always use caution if a fitting is removed. Slowly loosen the fitting. If the system is still under any pressure, release it slowly in a well-ventilated area.
- DO NOT smoke when servicing A/C or wherever refrigerant gas may be present.
- Failure to follow these warnings may result in injury or death to personnel.

NOTE

Install hoses and wires as tagged during removal.

EVAPORATOR ASSEMBLY MAINTENANCE - CONTINUED**0017 00****INSTALLATION - CONTINUED**

9. Install lower evaporator assembly bracket (19), washer (21), bolt (20), washer (22), new locknut (23), and two bolts (18) on evaporator assembly (1).
10. Install upper evaporator assembly bracket (15), washer (13), bolt (12), new locknut (14), washer (17), and bolt (16), on evaporator assembly (1).
11. Install air filter gauge (11), two washers (9), bolts (8), and new locknuts (10) on evaporator assembly (1).
12. Install new tiedown strap as required.
13. Connect power and ground harness connector (26) on evaporator assembly (1).
14. Connect receiver/dryer wiring harness connector (27) on evaporator assembly (1).
15. Connect wiring harness connector (28) on evaporator assembly (1).
16. Apply refrigerant oil to new O-ring and connect A/C hose connection (25) on evaporator assembly (1).
17. Apply refrigerant oil to new O-ring and connect A/C hose connection (24) on evaporator assembly (1).

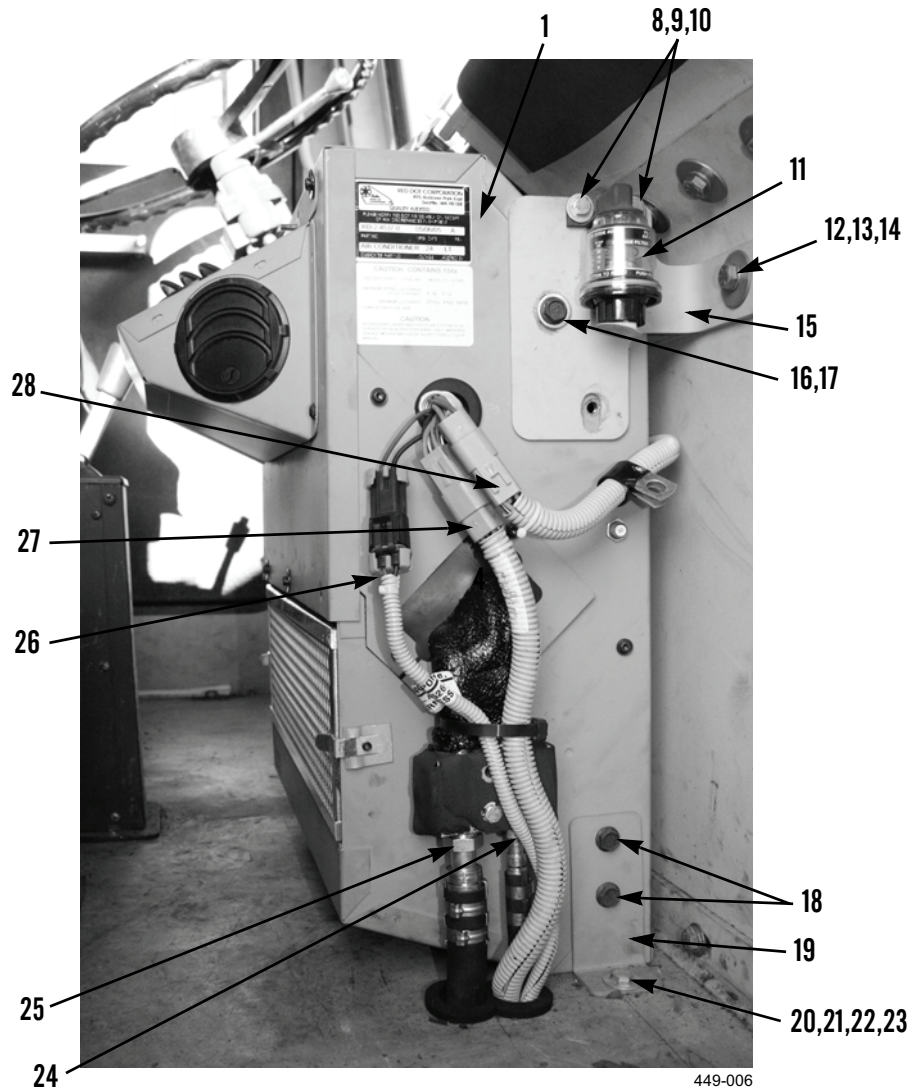

INSTALLATION - CONTINUED

18. Install access cover (5), washer (7), and bolt (6) on evaporator assembly (1).
19. Install P-clamp (4), washer (3), and bolt (2) on evaporator assembly (1).

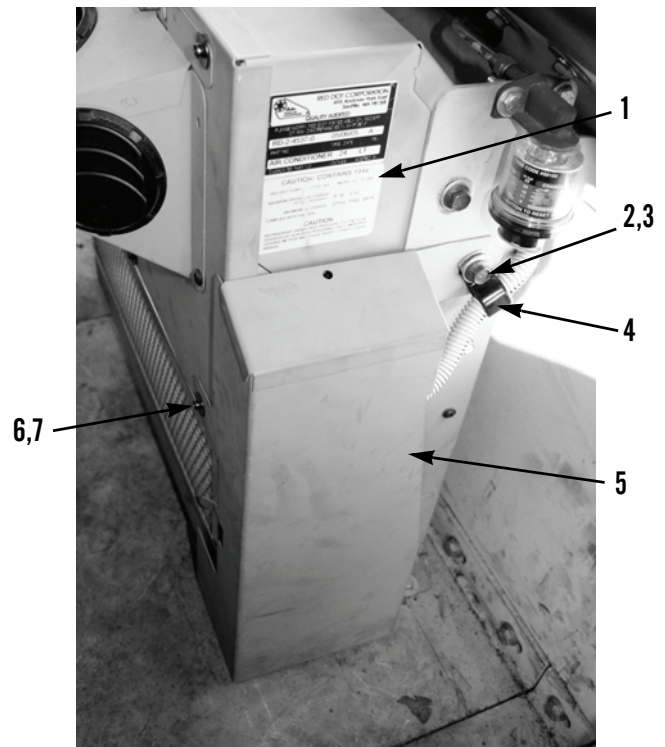

449-020

20. Install air filter (WP 0010 00).
21. Evacuate and recharge A/C system (WP 0015 00).
22. Verify correct operation of A/C system (WP 0004 00).

END OF WORK PACKAGE

CONDENSER REPLACEMENT

0018 00

THIS WORK PACKAGE COVERSRemoval, Cleaning and Inspection, Installation

INITIAL SETUP**Maintenance Level**

Direct Support

Tools and Special Tools

Tool Kit, General Mechanic's (Item 9, WP 0024 00)

Shop Equipment, Common No. 1 (Item 6, WP 0024 00)

Reclaimer, Refrigerant (Item 5, WP 0024 00)

Tool Kit, Refrigeration Equipment (Item 10, WP 0024 00)

Wrench Set, Torx (Item 11, WP 0024 00)

Materials/Parts

Oil, Lubricating, Refrigerant Compressor (Item 8, WP 0025 00)

Rag, Wiping (Item 9, WP 0025 00)

Strap, Tiedown (Item 12, WP 0025 00)

Tag, Marker (Item 13, WP 0025 00)

Locknut (8)

O-ring (2)

Personnel Required

Two

References

WP 0014 00

Equipment Conditions**(M915A1P1)**

Vehicle parked on level ground (TM 9-2320-283-10)

Parking/Emergency Brake applied (TM 9-2320-283-10)

Engine OFF (TM 9-2320-283-10)

Ignition Key Switch in OFF position (TM 9-2320-283-10)

A/C Refrigerant recovered (WP 0015 00)

(M915P1, M916P1, M917P1, and M920P1)

Vehicle parked on level ground (TM 9-2320-273-10)

Parking/Emergency Brake applied (TM 9-2320-273-10)

Engine OFF (TM 9-2320-273-10)

Ignition Key Switch in OFF position (TM 9-2320-273-10)

A/C Refrigerant recovered (WP 0015 00)

**WARNING**

- Contact with refrigerant can cause frostbite. Keep hands and face away to prevent personal injury.
- Protective face shield must always be worn when refrigerant lines are opened, even if the gauges indicate the system is empty.
- Always use caution if a fitting is removed. Slowly loosen the fitting. If the system is still under any pressure, release it slowly in a well-ventilated area.
- DO NOT smoke when servicing A/C or wherever refrigerant gas may be present.
- Failure to follow these warnings may result in injury or death to personnel.

CAUTION

Cap all A/C hose ends and component connections during removal to protect against contamination. Failure to comply may cause damage to equipment.

REMOVAL**NOTE**

Tag wires and hoses to aid in installation.

1. Remove A/C hose (8) from condenser (5). Discard O-ring.
2. Remove A/C hose (9) from condenser (5). Discard O-ring.
3. Remove all tiedown straps (3) from EMI filter assembly connector (1), right condenser fan connector (4), and left condenser fan connector (2). Discard tiedown straps.
4. Disconnect wiring harness connector (7) from main wiring harness. May require removal of spiral wrap (6).
5. Remove left condenser fan connector (2) and right condenser fan connector (4) from EMI filter assembly connector (1).
6. Remove sealant from around eight locknuts (10).
7. Remove eight locknuts (10), washers (11), bolts (12), and washers (13) from condenser (5) and roof armor (14). Discard locknuts.

**WARNING**

A/C condenser weighs 40 lb (18 kg). Use caution when handling heavy parts. Provide adequate support and use assistance during procedure. Failure to follow this warning may cause injury to personnel.

CONDENSER REPLACEMENT - CONTINUED

0018 00

REMOVAL - CONTINUED

8. With assistance, remove condenser (5) from vehicle.

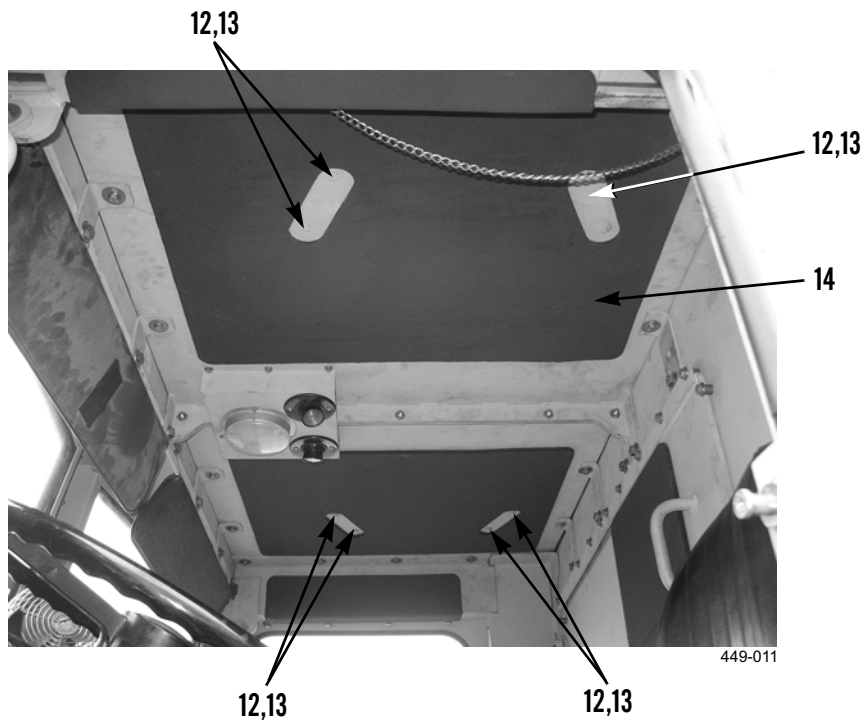
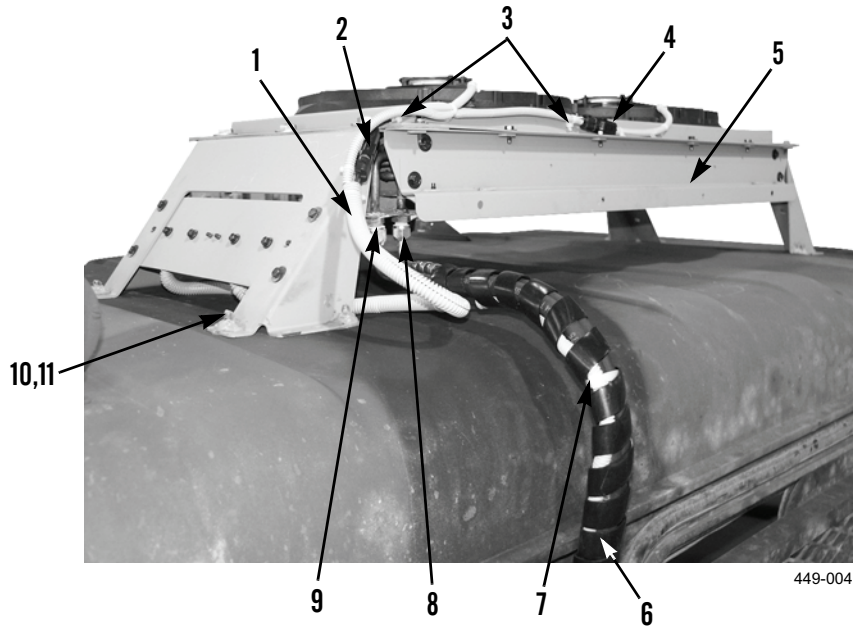

CONDENSER REPLACEMENT - CONTINUED

0018 00

REMOVAL - CONTINUED**NOTE**

- Only remove condenser fans and EMI filter assembly if required.
- Step 9 removes right side condenser fan from condenser. Repeat step 9 to remove left side condenser fan.

9. If required, remove four screws (15) and condenser fan (16) from condenser (5).

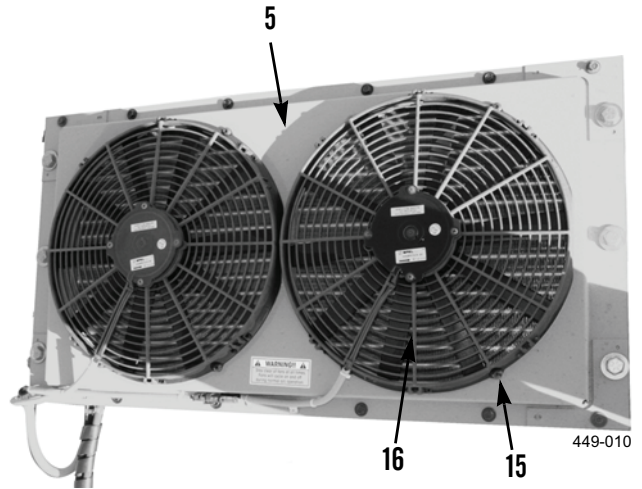

10. If required, remove four screws (17), washers (18), and EMI filter assembly (19) from condenser (5).

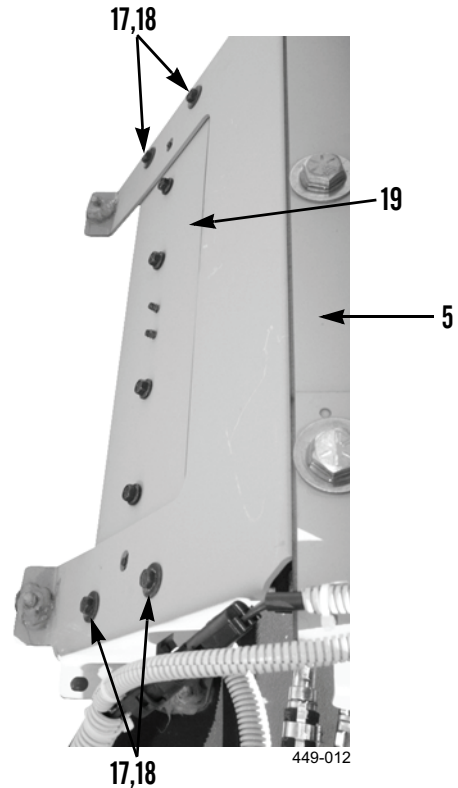

CLEANING AND INSPECTION

Clean and inspect all parts IAW *General Maintenance Instructions* (WP 0014 00).

INSTALLATION**NOTE**

Steps 1 through 3 install right side condenser fan on condenser. Repeat steps to install left side condenser fan.

1. If removed, install EMI filter assembly (19), four washers (18), and screws (17) on condenser (5).
2. If removed, install condenser fan (16) and four screws (15) on condenser (5).



Use caution when using adhesives and sealants. Prolonged inhalation of vapors can cause lung irritation. Contact with skin can cause dermatitis. Wear gloves and safety goggles and use product in a well-ventilated area away from open flame. If ingested, keep individual calm and seek medical attention. DO NOT induce vomiting. If contact with skin or eyes is made, flush thoroughly with water. Dispose of cleanup rags IAW local policy and ordinances. Failure to follow this warning may cause injury to personnel.

**WARNING**

A/C condenser weighs 40 lb (18 kg). Use caution when handling heavy parts. Provide adequate support and use assistance during procedure. Failure to follow this warning may cause injury to personnel.

INSTALLATION - CONTINUED

3. With assistance, place condenser (5) on vehicle and align bolt holes (12) in roof with bolt holes in condenser (5).
4. Install eight washers (13), bolts (12), washers (11), and new locknuts (10) on condenser (5).
5. Apply sealant around eight new locknuts (10) on condenser (5).

NOTE

Install wires and hoses as tagged during removal.

6. Connect right condenser fan connector (4) and left condenser fan connector (2) to EMI filter assembly connector (1).
7. Connect wiring harness connector (7) to main wiring harness. May require removal of spiral wrap (6).
8. Install new tiedown straps (3) as required on left condenser fan connector (2), right condenser fan connector (4), and EMI filter assembly connector (1).
9. Apply refrigerant oil to new O-ring and install A/C hose (9) on condenser (5).
10. Apply refrigerant oil to new O-ring and install A/C hose (8) on condenser (5).

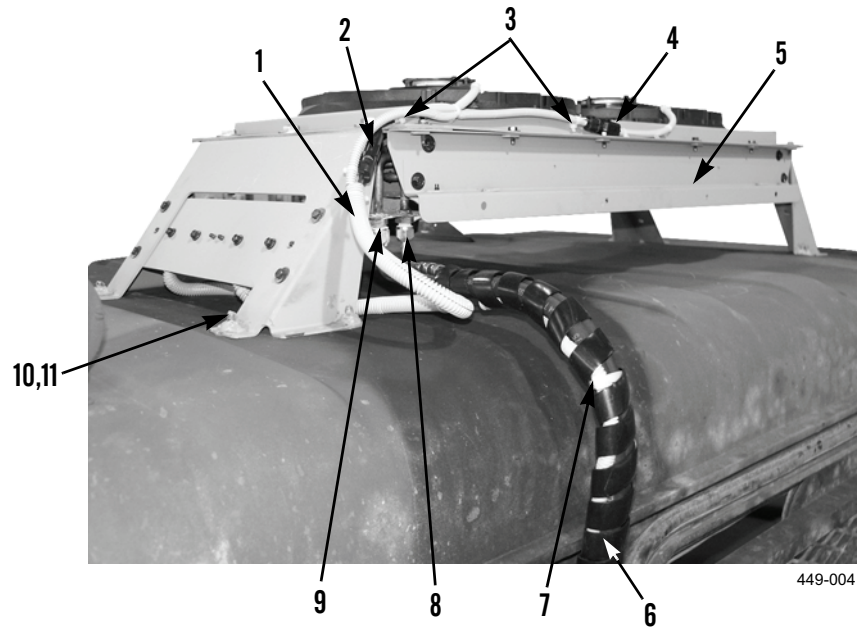

INSTALLATION - CONTINUED

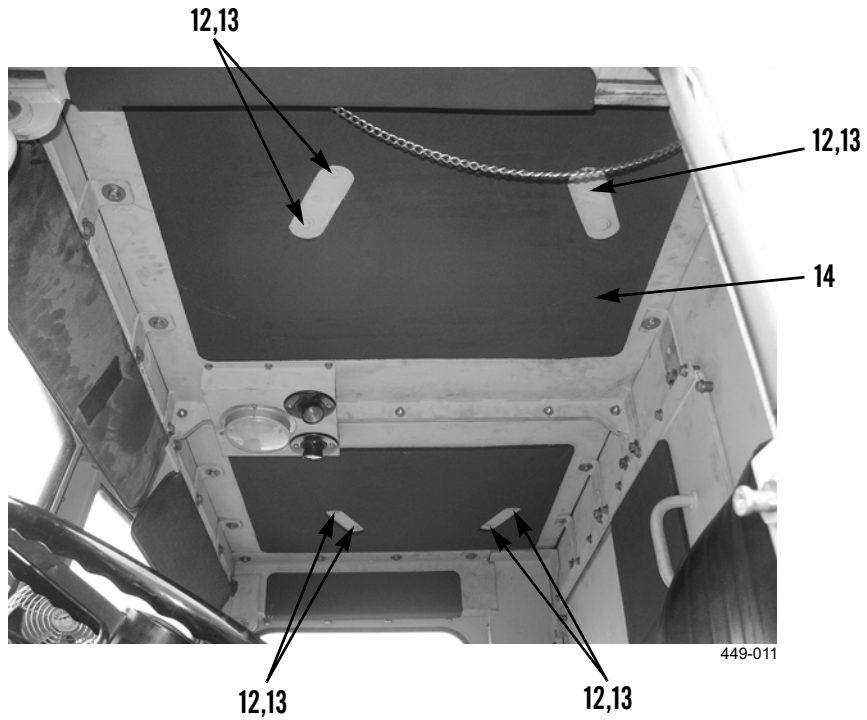

11. Evacuate and recharge A/C system (WP 0015 00).

END OF WORK PACKAGE

RECEIVER/DRYER REPLACEMENT

0019 00

THIS WORK PACKAGE COVERSRemoval, Cleaning and Inspection, Installation

INITIAL SETUP**Maintenance Level**

Direct Support

Tools and Special Tools

Tool Kit, General Mechanic's (Item 9, WP 0024 00)

Shop Equipment, Common No. 1 (Item 6, WP 0024 00)

Reclaimer, Refrigerant (Item 5, WP 0024 00)

Tool Kit, Refrigeration Equipment (Item 10, WP 0024 00)

Materials/Parts

Oil, Lubricating, Refrigerant Compressor (Item 8, WP 0025 00)

Rag, Wiping (Item 9, WP 0025 00)

Tag, Marker (Item 13, WP 0025 00)

O-ring (2)

References

WP 0014 00

Equipment Conditions**(M915A1P1)**

Vehicle parked on level ground (TM 9-2320-283-10)

Parking/Emergency Brake applied (TM 9-2320-283-10)

Engine OFF (TM 9-2320-283-10)

Ignition Key Switch in OFF position (TM 9-2320-283-10)

A/C Refrigerant recovered (WP 0015 00)

(M915P1, M916P1, M917P1, and M920P1)

Vehicle parked on level ground (TM 9-2320-273-10)

Parking/Emergency Brake applied (TM 9-2320-273-10)

Engine OFF (TM 9-2320-273-10)

Ignition Key Switch in OFF position (TM 9-2320-273-10)

A/C Refrigerant recovered (WP 0015 00)

CAUTION

Cap all A/C hose ends and component connections during removal to protect against contamination. Failure to comply may cause damage to equipment.

REMOVAL**NOTE**

Tag wires and hoses to aid in installation.

1. Remove A/C hose (1) from receiver/dryer unit (7). Discard O-rings.
2. Remove A/C hose (4) from receiver/dryer unit (7). Discard O-rings.
3. Disconnect wiring harness connector (3) (orange and white wires) from high pressure switch (10) on receiver/dryer unit (7).
4. Disconnect wiring harness connector (2) (orange and yellow wires) from condenser fan switch (9) on receiver/dryer unit (7).

**WARNING**

Receiver/dryer unit will fall when clamps are loosened. Support receiver/dryer while loosening clamps. Failure to follow this warning may cause injury to personnel.

5. Remove bolt (5), bracket (6), and receiver/dryer unit (7) from vehicle.
6. Loosen two clamps (8) and remove receiver/dryer unit (7) from bracket (6).
7. If required, remove high pressure switch (10) from receiver/dryer unit (7). Discard O-ring.
8. If required, remove condenser fan switch (9) from receiver/dryer unit (7). Discard O-ring.

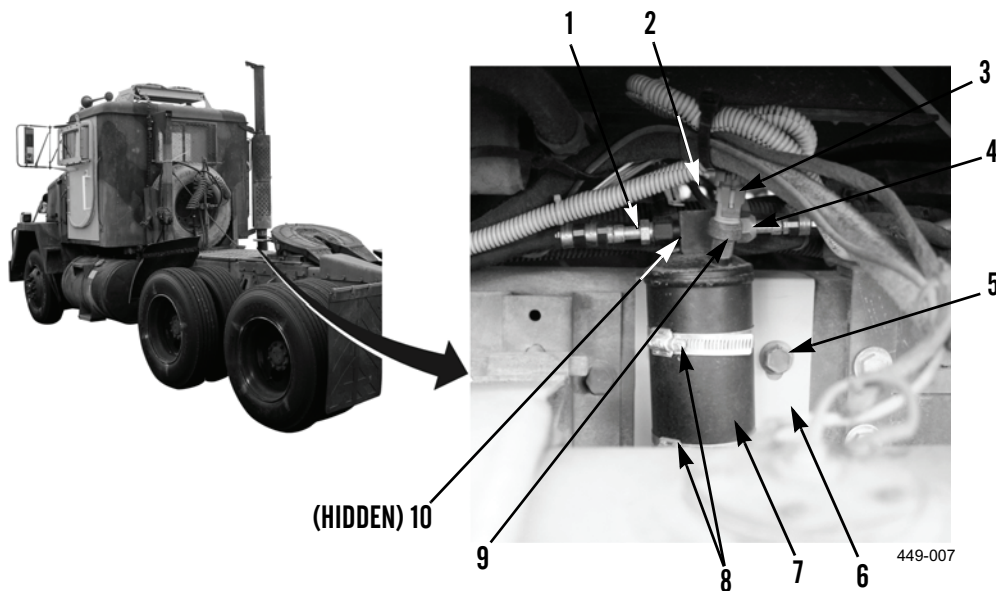
**CLEANING AND INSPECTION**

Clean and inspect all parts IAW *General Maintenance Instructions* (WP 0014 00).

INSTALLATION

1. If removed, apply refrigerant oil to new O-ring and install condenser fan switch (9) on receiver/dryer unit (7).
2. If removed, apply refrigerant oil to new O-ring and install high pressure switch (10) on receiver/dryer unit (7).

**WARNING**

Receiver/dryer unit will fall when clamps are loosened. Support receiver/dryer while loosening clamps. Failure to follow this warning may cause injury to personnel.

3. If removed, install receiver/dryer unit (7) inside two clamps (8) on bracket (6). Tighten clamps.

NOTE

Install wires and hoses as tagged during removal.

4. Install receiver/dryer unit (7) with bracket (6) and bolt (5) on vehicle.
5. Connect wiring harness connector (3) (orange and yellow wires) to condenser fan switch (9) on receiver/dryer unit (7).
6. Connect wiring harness connector (2) (orange and white wires) to high pressure switch (10) on receiver/dryer unit (7).
7. Apply refrigerant oil to new O-ring and install A/C hose (4) on receiver/dryer unit (7).
8. Apply refrigerant oil to new O-ring and install A/C hose (1) on receiver/dryer unit (7).
9. Evacuate and recharge A/C system (WP 0015 00).

END OF WORK PACKAGE

A/C HOSE REPLACEMENT

0020 00

THIS WORK PACKAGE COVERSRemoval, Cleaning and Inspection, Installation

INITIAL SETUP**Maintenance Level**

Direct Support

Tools and Special Tools

Tool Kit, General Mechanic's (Item 9, WP 0024 00)

Shop Equipment, Common No. 1 (Item 6, WP 0024 00)

Reclaimer, Refrigerant (Item 5, WP 0024 00)

Tool Kit, Refrigeration Equipment (Item 10, WP 0024 00)

Materials/Parts

Oil, Lubricating, Refrigerant Compressor (Item 8, WP 0025 00)

Rag, Wiping (Item 9, WP 0025 00)

Refrigerant, (4V886) R-134a (Item 10, WP 0025 00)

Strap, Tiedown (Item 12, WP 0025 00)

Tag, Marker (Item 13, WP 0025 00)

O-ring (8)

References

WP 0014 00

Equipment Conditions**(M915A1P1)**

Vehicle parked on level ground (TM 9-2320-283-10)

Parking/Emergency Brake applied (TM 9-2320-283-10)

Engine OFF (TM 9-2320-283-10)

Ignition Key Switch in OFF position (TM 9-2320-283-10)

Battery Cables disconnected (TM 9-2320-283-20)

Left Hood opened (TM 9-2320-283-10)

A/C Refrigerant recovered (WP 0015 00)

(M915P1, M916P1, M917P1, and M920P1)

Vehicle parked on level ground (TM 9-2320-273-10)

Parking/Emergency Brake applied (TM 9-2320-273-10)

Engine OFF (TM 9-2320-273-10)

Ignition Key Switch in OFF position (TM 9-2320-273-10)

Battery Cables disconnected (TM 9-2320-273-20)

Left Hood opened (TM 9-2320-273-10)

A/C Refrigerant recovered (WP 0015 00)

REMOVAL**WARNING**

- Contact with refrigerant can cause frostbite. Keep hands and face away to prevent personal injury.
- Protective face shield must always be worn when refrigerant lines are opened, even if the gauges indicate the system is empty.
- Always use caution if a fitting is removed. Slowly loosen the fitting. If the system is still under any pressure, release it slowly in a well-ventilated area.
- DO NOT smoke when servicing A/C or wherever refrigerant gas may be present.
- Failure to follow these warnings may result in injury or death to personnel.

CAUTION

Cap all A/C hose ends and component connections during installation to protect against contamination. Failure to comply may cause damage to equipment.

NOTE

- Tag hoses to aid in installation.
 - Note routing of hoses prior to removal to aid installation.
1. Remove A/C hose connection (1) from condenser (3). Discard O-rings.
 2. Remove A/C hose connection (2) from condenser (3). Discard O-rings.

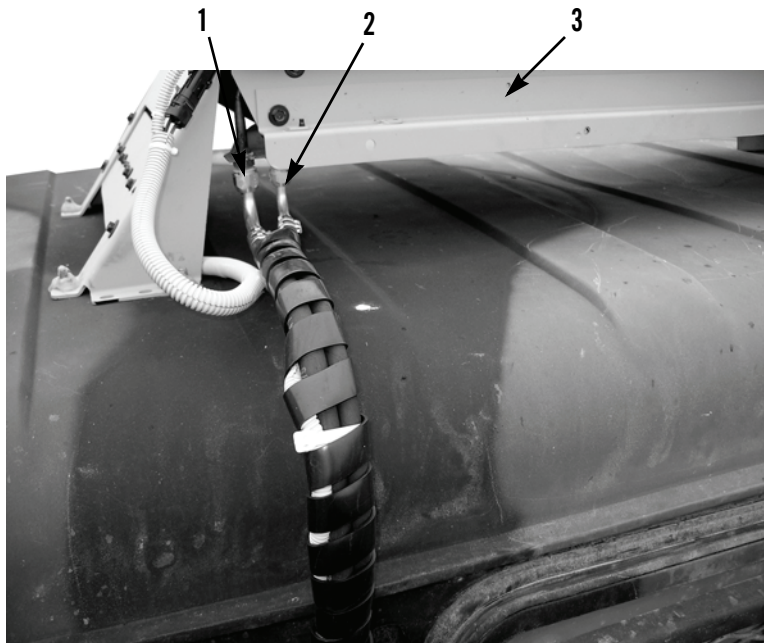

449-015

A/C HOSE REPLACEMENT - CONTINUED

0020 00

REMOVAL - CONTINUED

3. Remove two nuts (5), P-clamps (4), bolts (7), and washers (6) from rear window guard (10).
4. Reinstall two washers (6), bolts (7), and nuts (5) on rear window guard (10).
5. Remove tiedown strap (8) as necessary and spiral wrap (9) from A/C hoses (11). Discard tiedown strap.

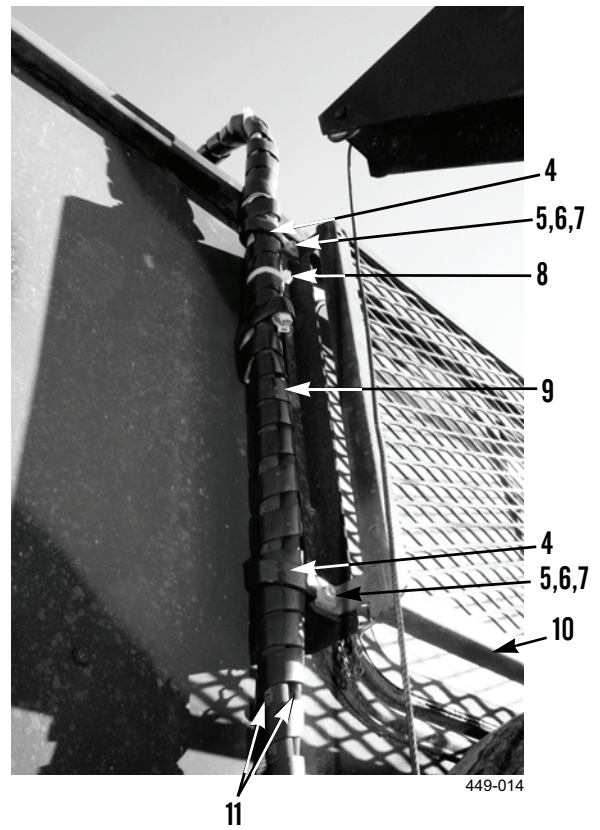

A/C HOSE REPLACEMENT - CONTINUED**0020 00****REMOVAL - CONTINUED**

6. Remove A/C hose connection (13) from receiver/dryer (15). Discard O-rings.
7. Remove A/C hose (14) from vehicle.
8. Remove A/C hose connection (12) from receiver/dryer (15). Discard O-rings.
9. Remove tiedown strap from A/C hoses from receiver/dryer and condenser on under side of cab. Discard tiedown strap.

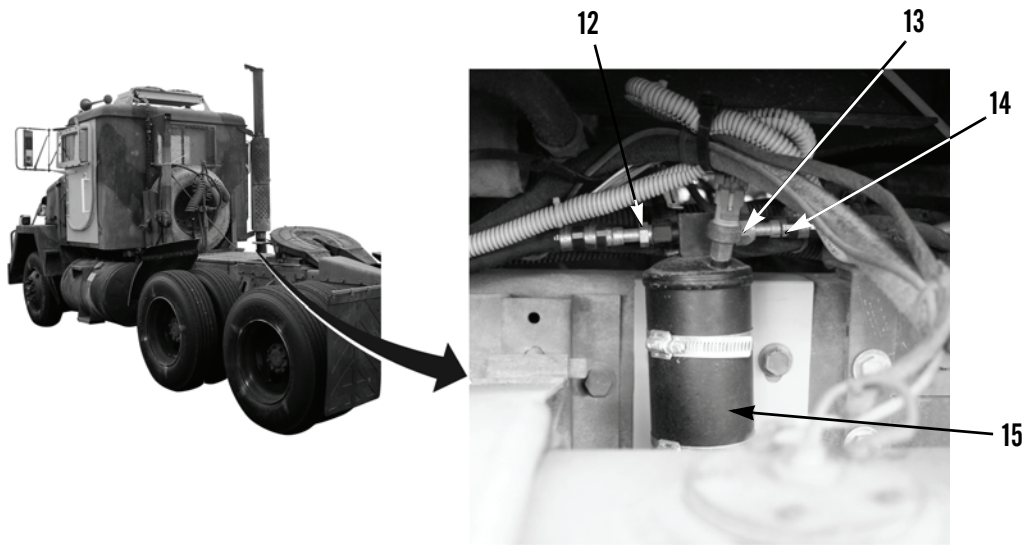

449-007

A/C HOSE REPLACEMENT - CONTINUED

0020 00

REMOVAL - CONTINUED

10. Remove bolt (16), washer (17), and P-clamp (18) from evaporator assembly (21).
11. Remove bolt (20) and access cover (19) from evaporator assembly (21).

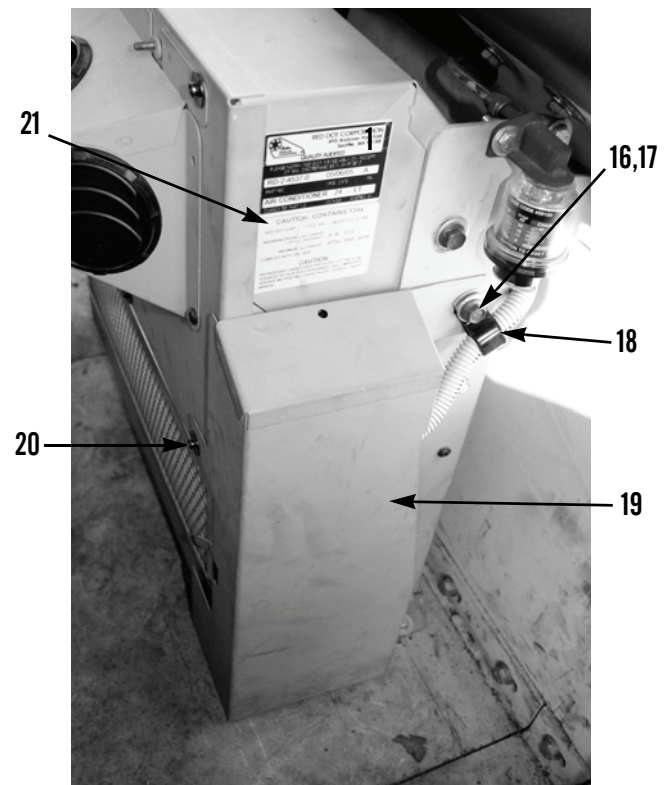

449-020

A/C HOSE REPLACEMENT - CONTINUED

0020 00

REMOVAL - CONTINUED

12. Remove A/C hose connection (22) from evaporator assembly (21). Discard O-rings.
13. Remove A/C hose connection (24) from evaporator assembly (21). Discard O-rings.
14. Push A/C hose connection (22) and hose connection (24) through grommet (23) in cab floor.
15. Pull A/C hose connection (22) and A/C hose connection (24) from under left side of vehicle.
16. Remove A/C hose (22) from vehicle.

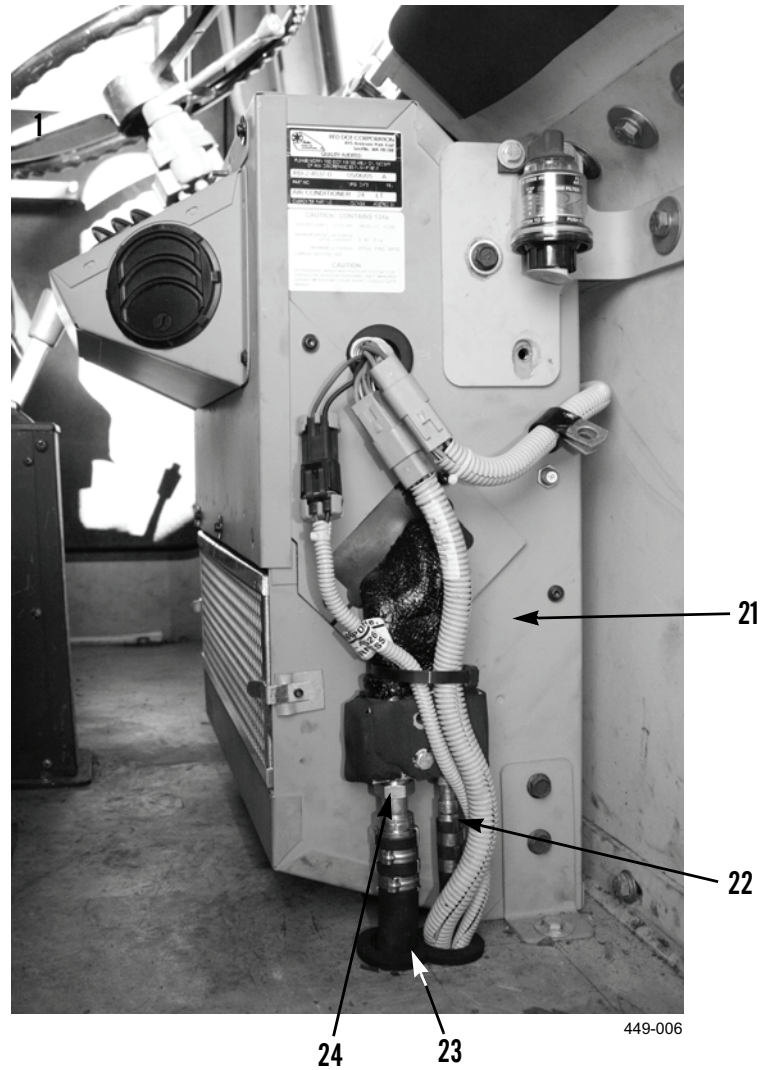

A/C HOSE REPLACEMENT - CONTINUED

0020 00

REMOVAL - CONTINUED

17. Remove A/C hose connection (25) from compressor (30). Discard O-rings.
18. Remove A/C hose connection (26) from compressor (30). Discard O-rings.
19. Remove tiedown strap and spiral wrap (28) from A/C hose (27) and A/C hose (29). Discard tiedown strap.
20. Remove A/C hose (27) and A/C hose (29) from vehicle.

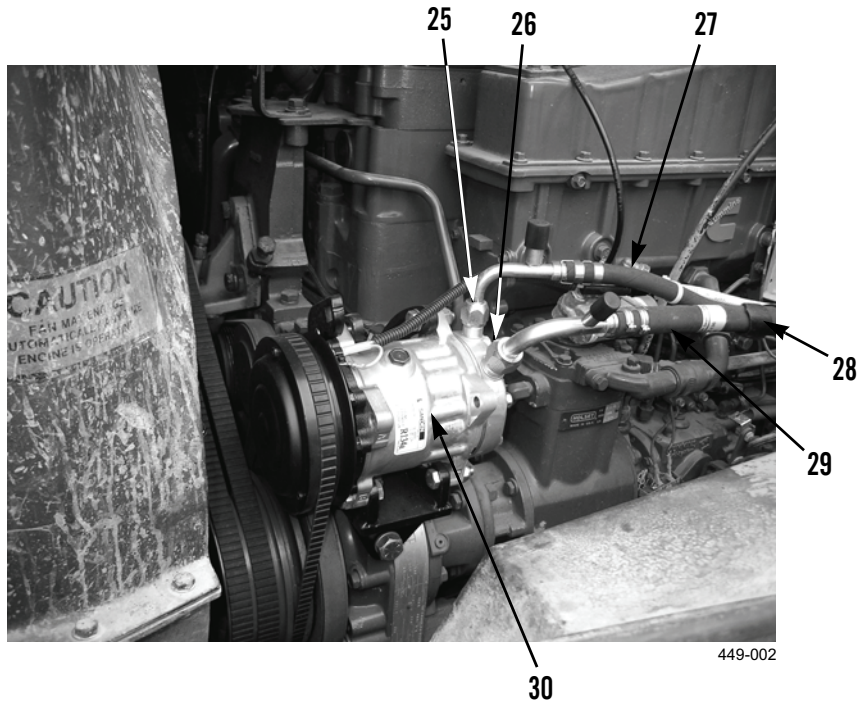
**CLEANING AND INSPECTION**

Clean and inspect all parts IAW *General Maintenance Instructions* (WP 0014 00).

INSTALLATION**WARNING**

- Contact with refrigerant can cause frostbite. Keep hands and face away to prevent personal injury.
- Protective face shield must always be worn when refrigerant lines are opened, even if the gauges indicate the system is empty.
- Always use caution if a fitting is removed. Slowly loosen the fitting. If the system is still under any pressure, release it slowly in a well-ventilated area.
- DO NOT smoke when servicing A/C or wherever refrigerant gas may be present.
- Failure to follow these warnings may result in injury or death to personnel.

INSTALLATION - CONTINUED**CAUTION**

Cap all A/C hose ends and component connections during installation to protect against contamination. Failure to comply may cause damage to equipment.

NOTE

- Install hoses as tagged at removal.
 - During installation, route hoses as noted during removal from vehicle.
1. Install A/C hose (29) and A/C hose (27) route from compressor to under left side of vehicle.
 2. Install spiral wrap (28) and new tiedown strap on A/C hose (29) and A/C hose (27).
 3. Apply refrigerant oil to new O-ring and install A/C hose connection (26) on compressor (30).
 4. Apply refrigerant oil to new O-ring and install A/C hose connection (25) on compressor (30).

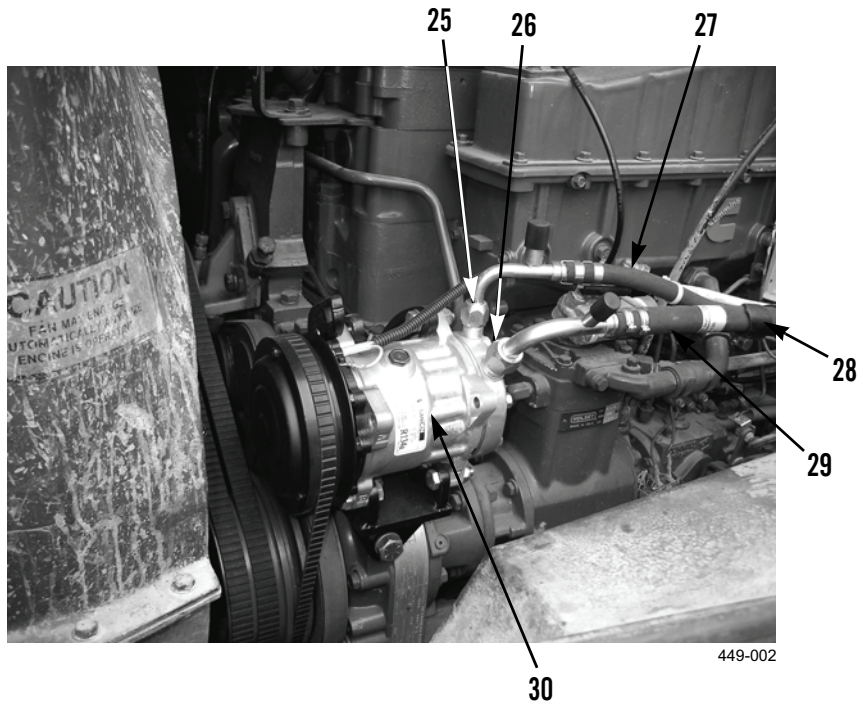

INSTALLATION - CONTINUED

5. Install A/C hose (22), route from receiver/dryer to evaporator assembly (21) under left side of vehicle.
6. Push A/C hose connection (22) (from compressor) and A/C hose connection (24) (routed from receiver/dryer) through grommet (23) from under left side of vehicle.
7. Apply refrigerant oil to new O-ring and install A/C hose connection (24) on evaporator assembly (21).
8. Apply refrigerant oil to new O-ring and install A/C hose connection (22) on evaporator assembly (21).

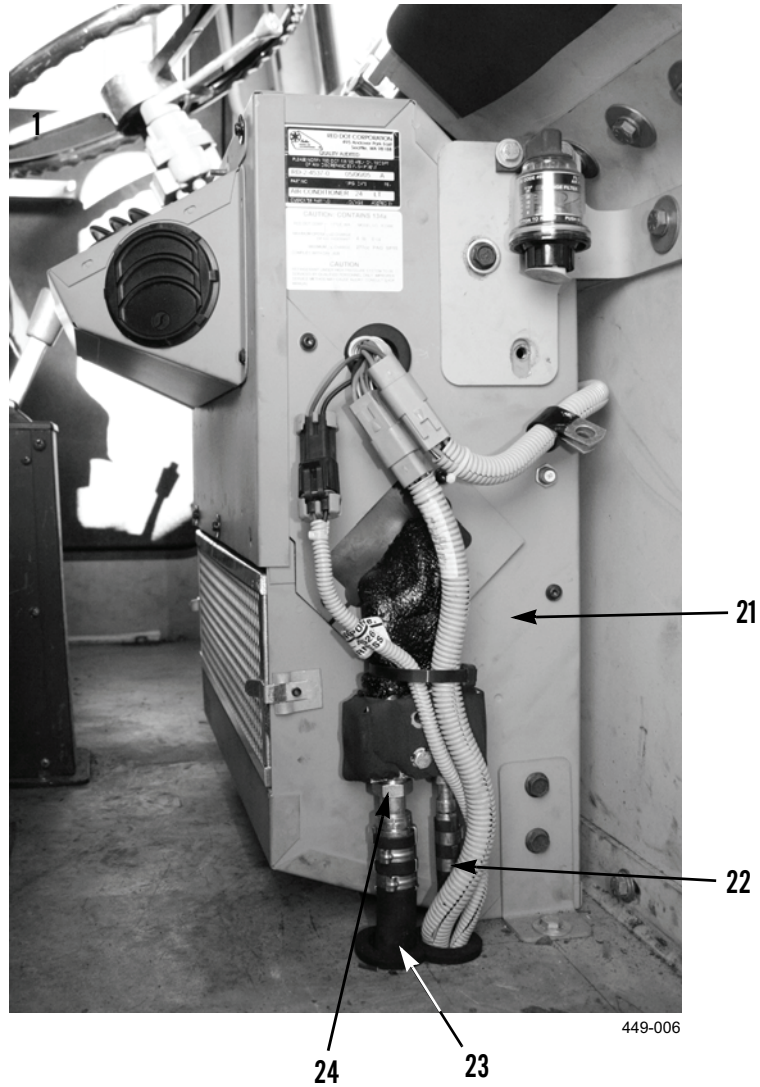

INSTALLATION - CONTINUED

9. Install access cover (19) and bolt (20) on evaporator assembly (21).
10. Install P-clamp (18), washer (17), and bolt (16) on evaporator assembly (21).

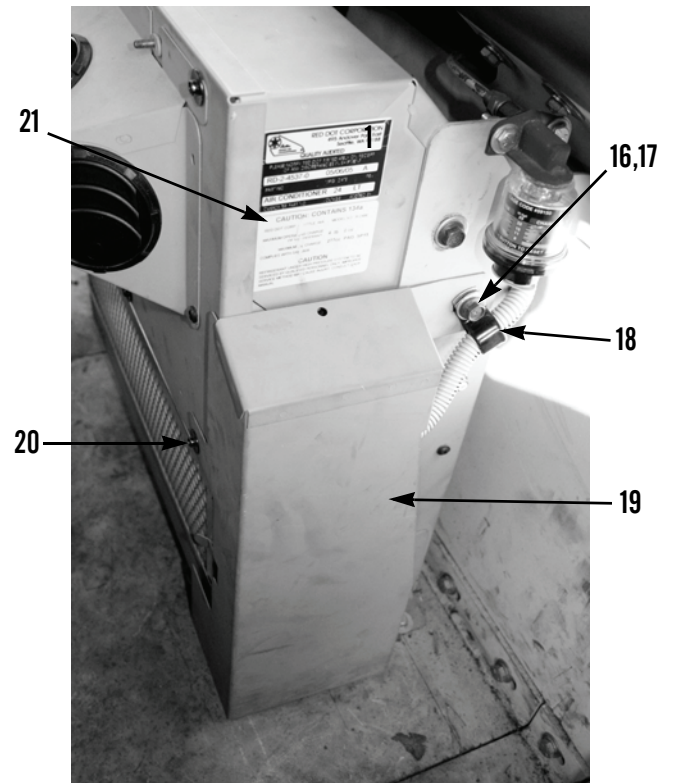

449-020

A/C HOSE REPLACEMENT - CONTINUED**0020 00****INSTALLATION - CONTINUED**

11. Install new tiedown strap on A/C hoses to receiver/dryer and from compressor on under left side of cab.
12. Apply refrigerant oil to new O-ring and install A/C hose connection (12) on receiver/dryer (15).
13. Install A/C hose (14) from receiver/dryer to rear left side of vehicle.
14. Apply refrigerant oil to new O-ring and install A/C hose connection (13) on receiver/dryer (15).

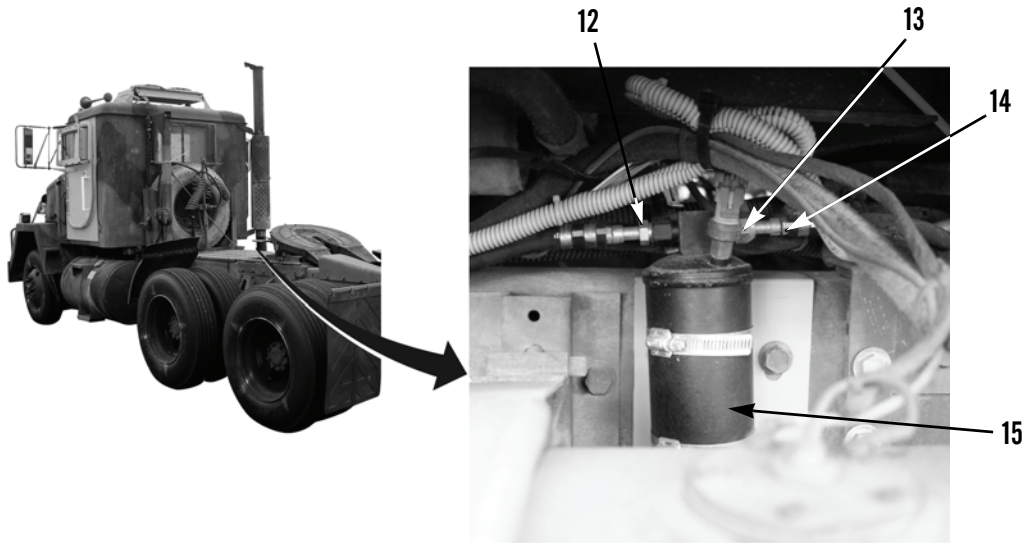

449-007

A/C HOSE REPLACEMENT - CONTINUED

0020 00

INSTALLATION - CONTINUED

15. Install spiral wrap (9) and cable ties (8) as necessary on A/C hoses (11).
16. Remove two nuts (5), bolts (7), and washers (6) from rear window guard (10).
17. Install two washers (6), bolts (7), P-clamps (4), and nuts (5) on rear window guard (10).

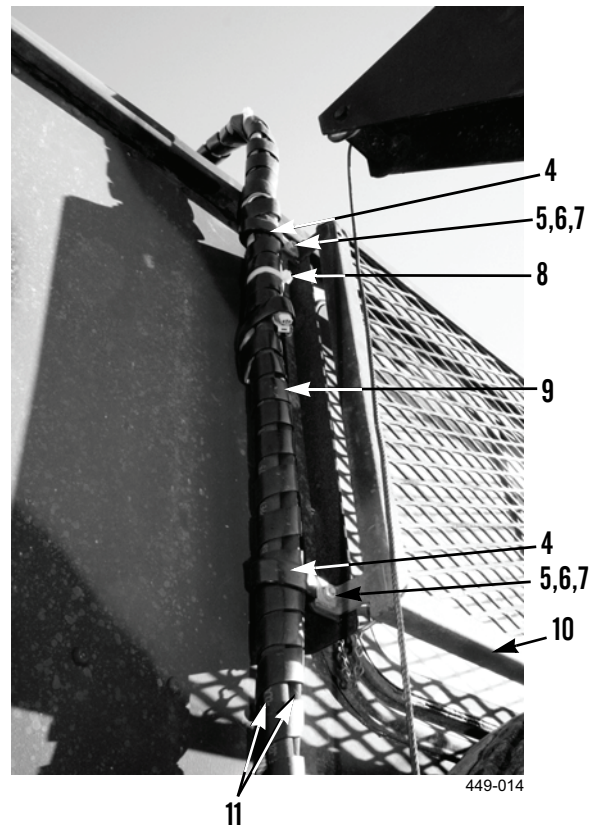

INSTALLATION - CONTINUED

18. Apply refrigerant oil to new O-ring and install A/C hose connection (2) on condenser (3).
19. Apply refrigerant oil to new O-ring and install A/C hose connection (1) on condenser (3).

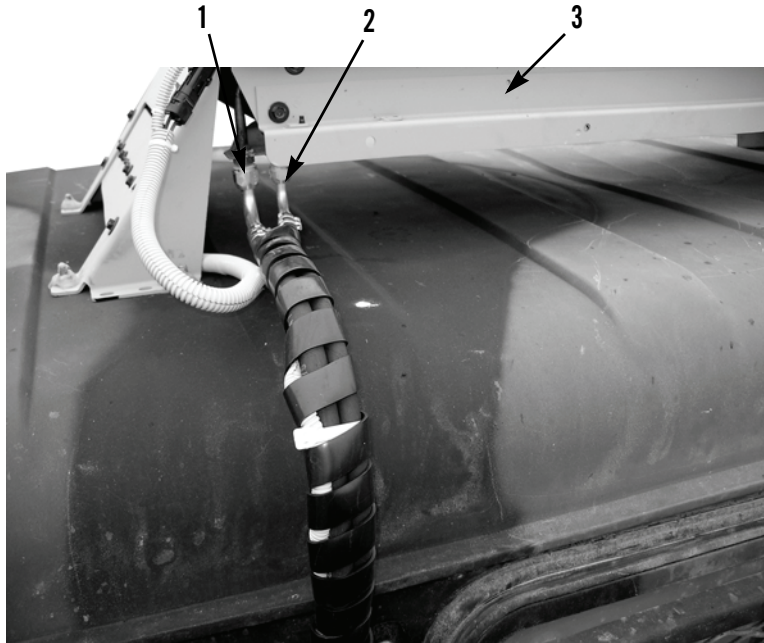

449-015

20. Evacuate and recharge A/C system (WP 0015 00).
21. Close hood (TM 9-2320-273-10 and TM 9-2320-283-10).
22. Connect battery cables (TM 9-2320-273-20 and TM 9-2320-283-10).

END OF WORK PACKAGE

A/C WIRING HARNESS REPLACEMENT

0021 00

THIS WORK PACKAGE COVERS

Removal, Cleaning and Inspection, Installation

INITIAL SETUP

Maintenance Level

Direct Support

Tools and Special Tools

Tool Kit, General Mechanic's (Item 9, WP 0024 00)

Shop Equipment, Common No. 1 (Item 6, WP 0024 00)

Tool Kit, Refrigeration Equipment (Item 10, WP 0024 00)

Materials/Parts

Oil, Lubricating, Refrigerant Compressor (Item 8, WP 0025 00)

Rag, Wiping (Item 9, WP 0025 00)

Refrigerant, (4V886) R-134a (Item 10, WP 0025 00)

Strap, Tiedown (Item 12, WP 0025 00)

Tag, Marker (Item 13, WP 0025 00)

References

WP 0014 00

Equipment Conditions

(M915A1P1)

Vehicle parked on level ground (TM 9-2320-283-10)

Parking/Emergency Brake applied (TM 9-2320-283-10)

Engine OFF (TM 9-2320-283-10)

Ignition Key Switch in OFF position (TM 9-2320-283-10)

Battery Cables disconnected (TM 9-2320-283-20)

Left Hood opened (TM 9-2320-283-10)

(M915P1, M916P1, M917P1, and M920P1)

Vehicle parked on level ground (TM 9-2320-273-10)

Parking/Emergency Brake applied (TM 9-2320-273-10)

Engine OFF (TM 9-2320-273-10)

Ignition Key Switch in OFF position (TM 9-2320-273-10)

Battery Cables disconnected (TM 9-2320-273-20)

Left Hood opened (TM 9-2320-273-10)

REMOVAL**NOTE**

- Tag wires and wiring harnesses to aid in installation.
- Note routing of wiring harness prior to removal to aid installation.

1. Loosen four fasteners (1) and open instrument panel (2).



449-017

A/C WIRING HARNESS REPLACEMENT - CONTINUED

0021 00

REMOVAL - CONTINUED

2. Disconnect ignition wire (4) (white wire) from ignition switch (3).

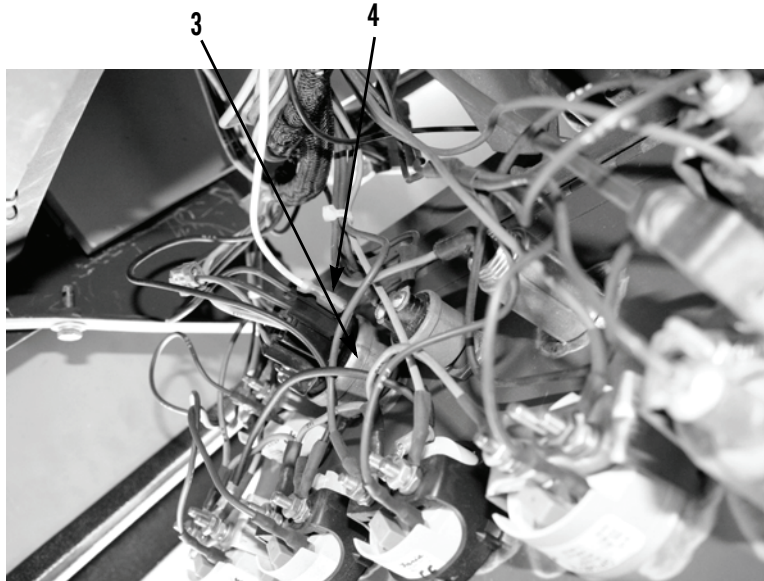

449-018

3. Remove four screws (6) and A/C switch box (5) from bracket (7).
4. Disconnect compressor clutch connector (8) (black with white stripe) from compressor wire through firewall.

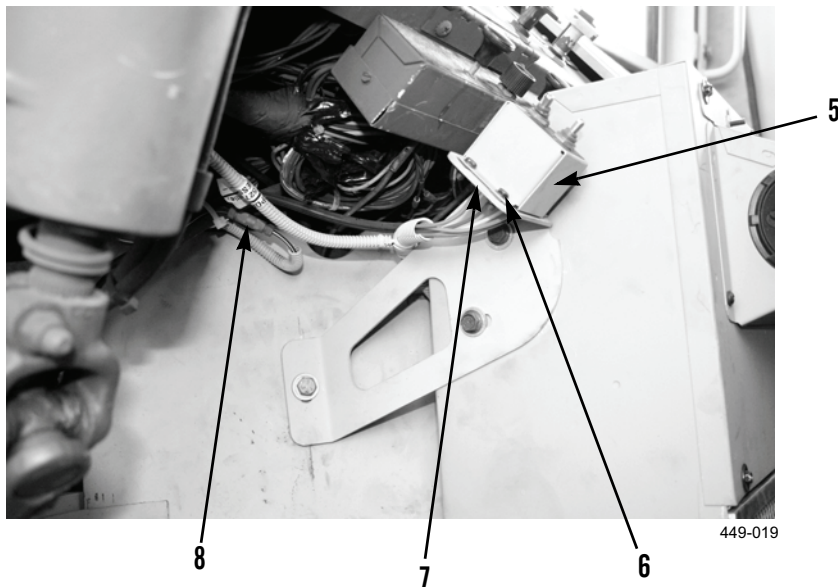

449-019

REMOVAL - CONTINUED

5. Remove bolt (9), washer (10), and P-clamp (11) from evaporator assembly (14).
6. Remove bolt (13) and access cover (12) from evaporator assembly (14).

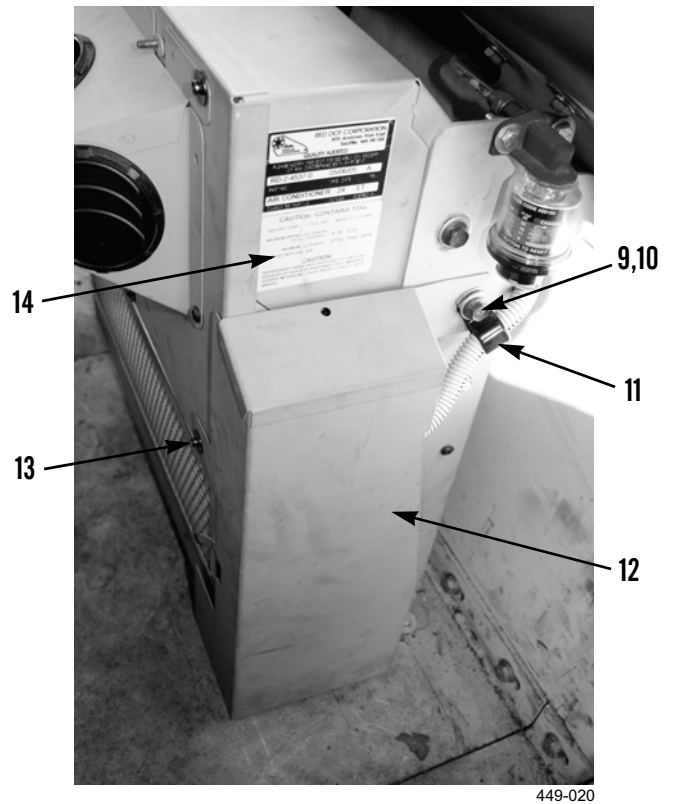

A/C WIRING HARNESS REPLACEMENT - CONTINUED**0021 00****REMOVAL - CONTINUED**

7. Disconnect switch wiring harness connector (15) from evaporator assembly (14).
8. Remove switch wiring harness with A/C switch box (16) from vehicle.
9. Remove tiedown straps (18) from evaporator extension harness (19) and power and ground harness (20). Discard tiedown straps.
10. Disconnect evaporator extension harness connector (17) from evaporator assembly (14).
11. Disconnect power and ground harness connector (21) from evaporator assembly (14).
12. Pull evaporator extension harness (19) and power and ground harness (20) through grommet from under left side of vehicle.

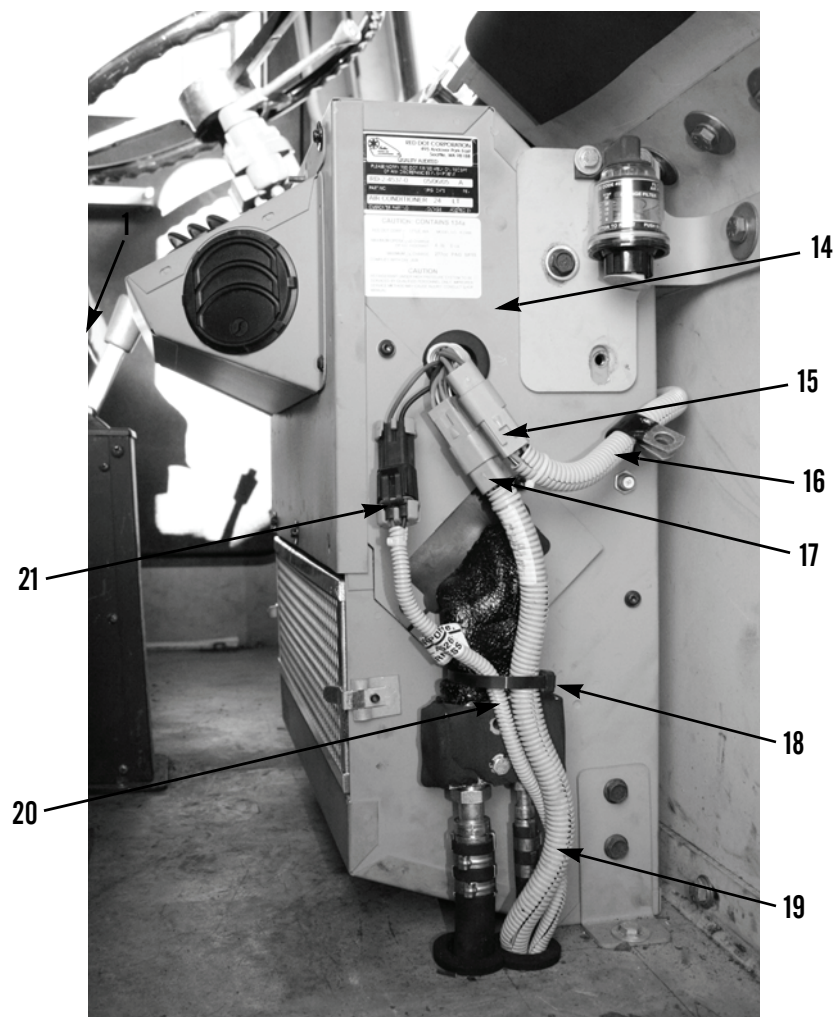

REMOVAL - CONTINUED

13. Remove bolt (23) and wiring harness positive connector (24) from battery positive terminal (22).
14. Remove bolt (26) and wiring harness negative connector (27) from battery negative terminal (25).
15. Remove all tiedown straps from power and ground harness (20) and remove from vehicle.

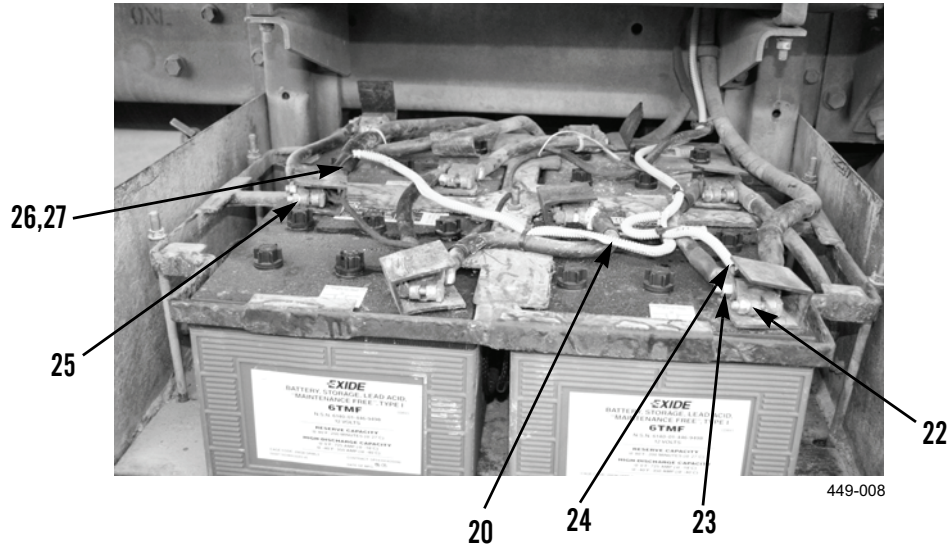

16. Disconnect compressor clutch connector (29) from compressor cable (30).
17. Remove all tiedown straps on compressor clutch wire (28) and pull it through hole in firewall.

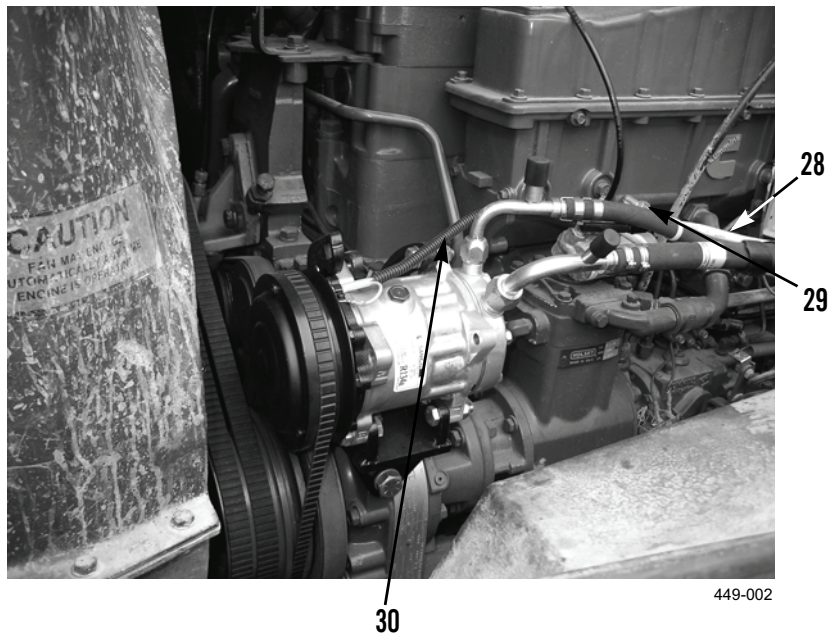

A/C WIRING HARNESS REPLACEMENT - CONTINUED**0021 00****REMOVAL - CONTINUED**

18. Disconnect receiver/dryer connector (34) from evaporator extension harness (19).
19. Remove all tiedown straps from evaporator extension harness (19) and remove from vehicle.
20. Disconnect wiring harness connector (33) (orange and white wires) from receiver/dryer unit (31).
21. Disconnect wiring harness connector (32) (orange and yellow wires) from receiver/dryer unit (31).

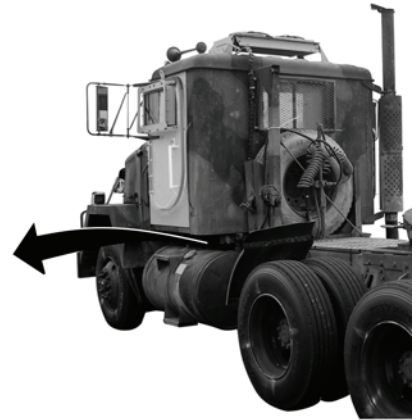
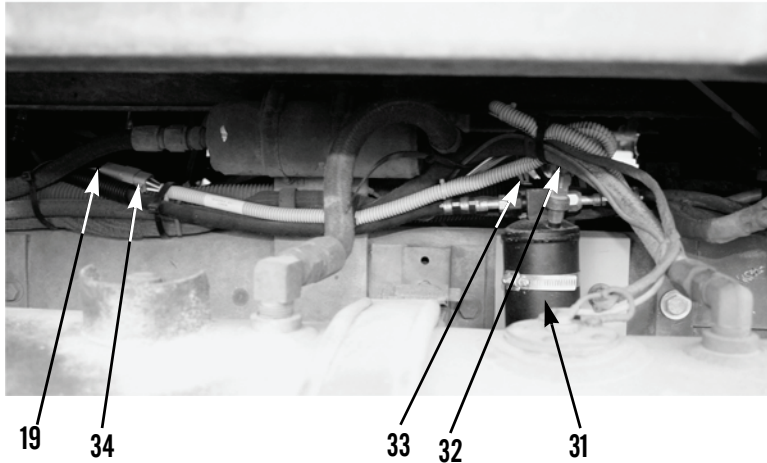

449-016

REMOVAL - CONTINUED

22. Remove two nuts (39), P-clamps (37), bolts (41), and washers (40) from rear window guard (43).
23. Reinstall two washers (40), bolts (41), and nuts (39) on rear window guard (43).
24. Remove tiedown straps (42) as necessary and spiral wrap (36) from receiver/dryer extension harness (44).
25. Disconnect receiver/dryer extension harness connector (38) from condenser cable (35).
26. Remove receiver/dryer extension harness (44) from vehicle.

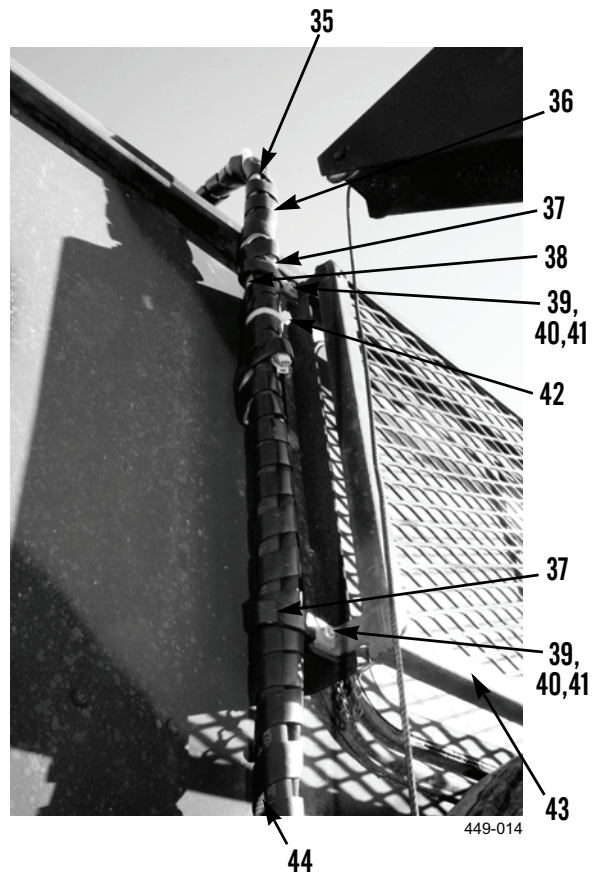

27. Remove all tiedown straps (42) from condenser cable (35) and relay assembly cable (48). Discard tiedown straps.
28. Remove left condenser fan connector (45) and right condenser fan connector (46) from relay assembly cable (48).
29. Remove four screws (49), washers (50), and EMI filter assembly (51) from condenser (47).

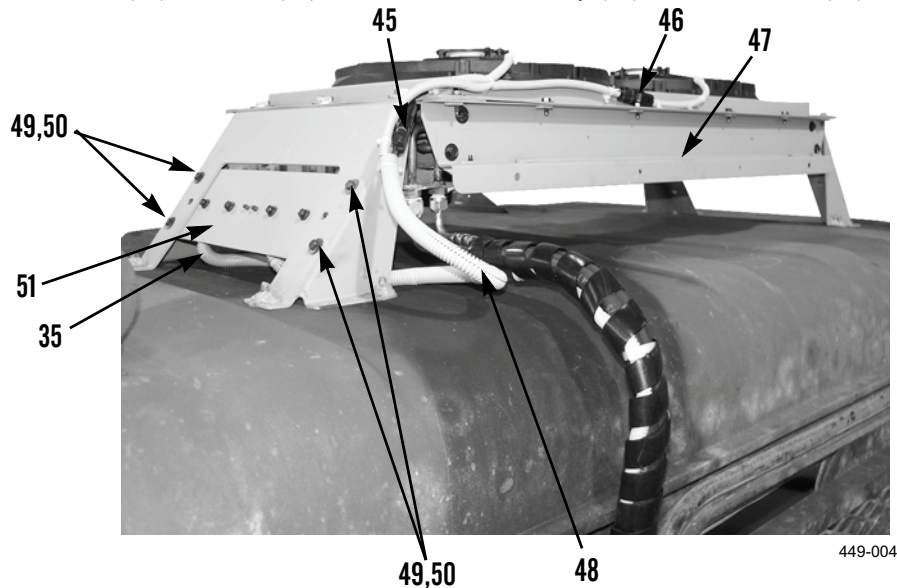

CLEANING AND INSPECTION

Clean and inspect all parts IAW *General Maintenance Instructions* (WP 0014 00).

INSTALLATION**NOTE**

- Install wires and wiring harness as tagged at removal.
 - During installation, route wiring harnesses as noted during removal.
1. Install EMI filter assembly (51), four washers (50), and screws (49) on condenser (47).
 2. Install right condenser fan connector (46) and left condenser fan connector (45) on relay assembly cable (48).
 3. Install cable ties as required (3) on condenser cable (35) and relay assembly cable (48).
 4. Install receiver/dryer extension harness (44) on rear of vehicle along condenser hoses.
 5. Connect receiver/dryer extension harness connector (38) to condenser cable (35).
 6. Install spiral wrap (36) and new tiedown strap (42) as necessary on receiver/dryer extension harness (44) and condenser hoses.
 7. Remove two nuts (39), bolts (41), and washers (40) from rear window guard (43).
 8. Install two washers (40), bolts (41), P-clamps (37), and nuts (39) on rear window guard (43).

A/C WIRING HARNESS REPLACEMENT - CONTINUED

0021 00

INSTALLATION - CONTINUED

9. Connect wiring harness connector (32) (orange and yellow wires) on receiver/dryer unit (31).
10. Connect wiring harness connector (33) (orange and white wires) on receiver/dryer unit (31).
11. Install evaporator extension harness (19) and connect receiver/dryer connector (34).
12. Install cable ties as necessary on evaporator extension harness (19).

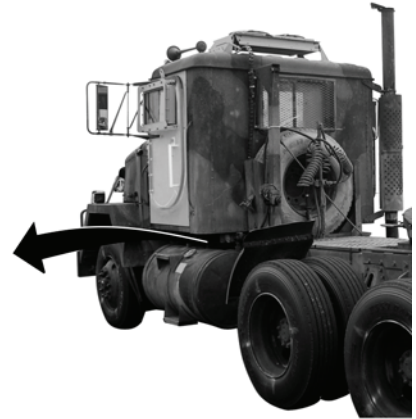
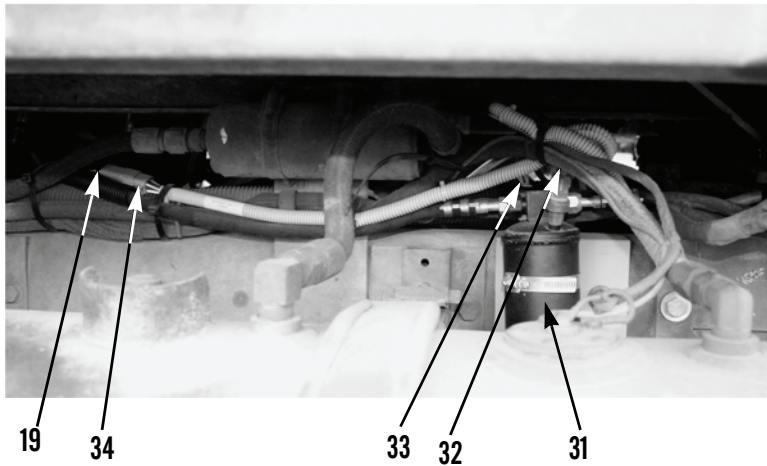

449-016

13. Route compressor clutch wire (28) through hole in firewall.
14. Connect compressor clutch connector (29) to compressor cable (30).
15. Install cable ties as required on compressor clutch wire (28).

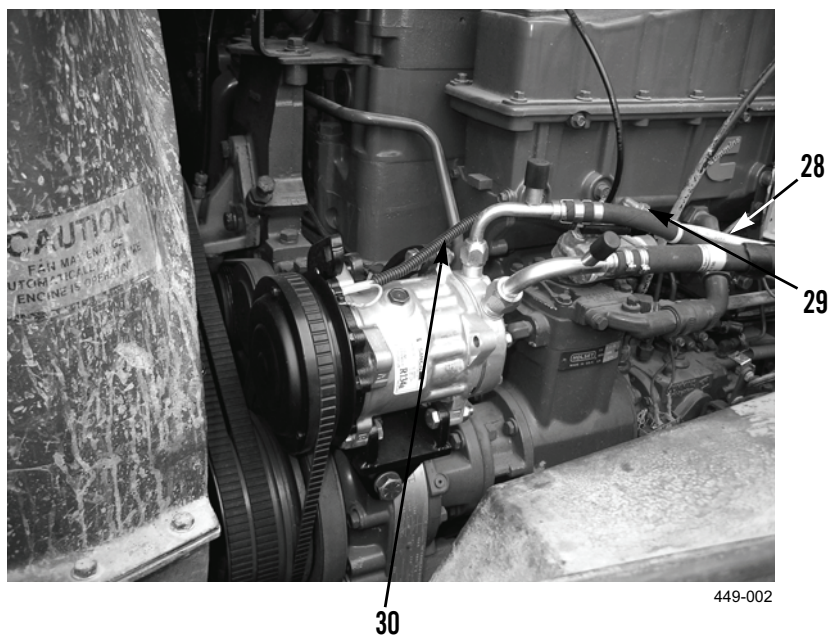

449-002

INSTALLATION - CONTINUED

16. Install ground harness (20), route wiring harness positive connector (24) to battery positive terminal (22) and route wiring harness negative connector (27) to battery negative terminal (25).
17. Install wiring harness negative connector (27) and bolt (26) on battery negative terminal (25).
18. Install wiring harness positive connector (24) and bolt (23) on battery positive terminal (22).

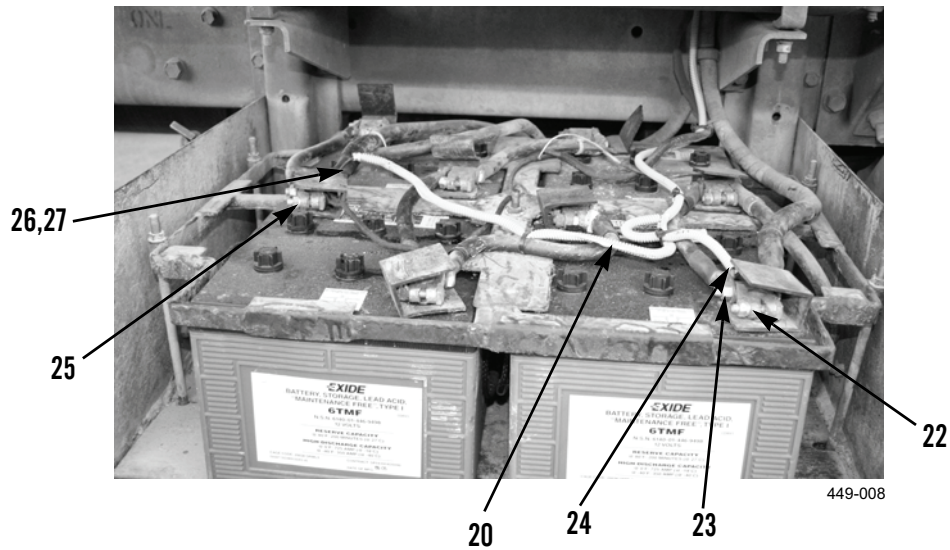

INSTALLATION - CONTINUED

19. Push power and ground harness (20) and evaporator extension harness (19) through grommet from under left side of vehicle.
20. Connect power and ground harness connector (21) to evaporator assembly (14).
21. Connect evaporator extension harness connector (17) to evaporator assembly (14).
22. Install new tiedown straps (18).
23. Install switch wiring harness with A/C switch box (16) route cable around back of evaporator assembly (14).
24. Connect switch wiring harness connector (15) to evaporator assembly (14).

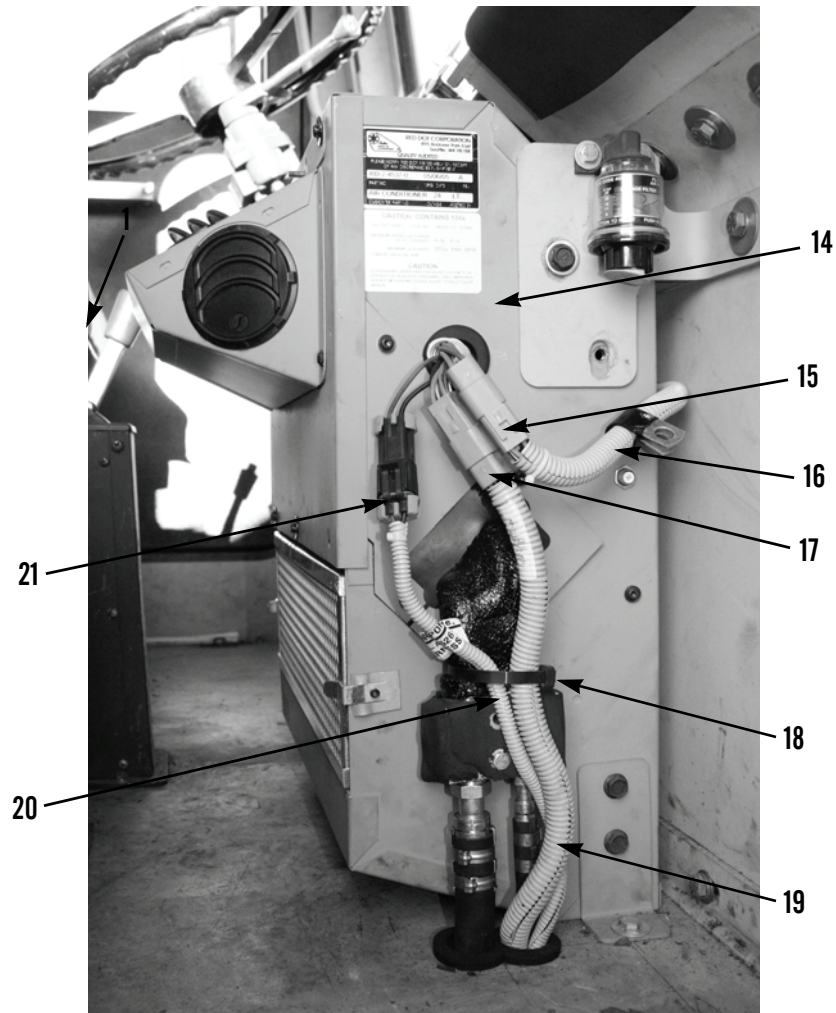

449-006

INSTALLATION - CONTINUED

25. Install access cover (12) and bolt (13) on evaporator assembly (14).
26. Install P-clamp (11), washer (10), and bolt (9) on evaporator assembly (14).

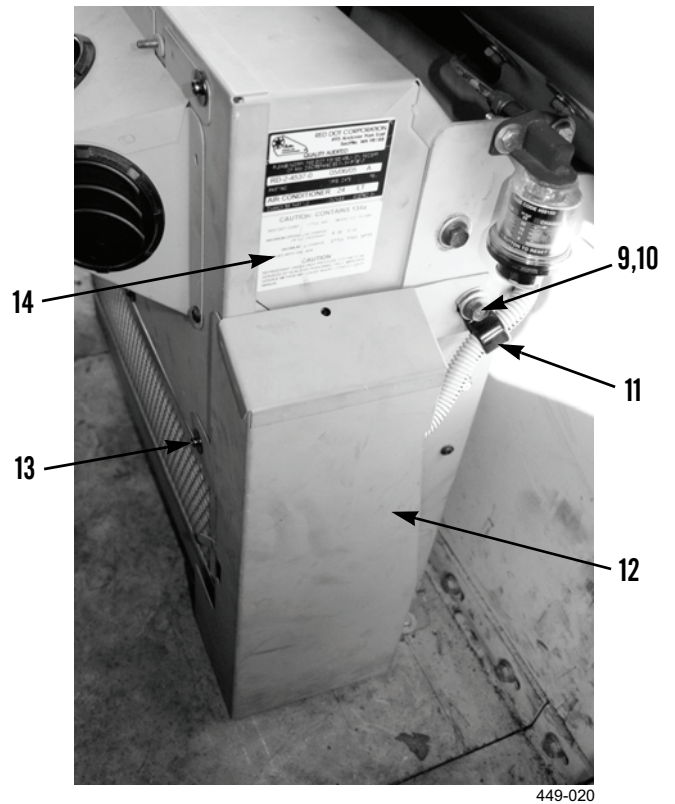

A/C WIRING HARNESS REPLACEMENT - CONTINUED**0021 00****INSTALLATION - CONTINUED**

27. Connect compressor clutch connector (8) (black with white stripe) on wire from compressor through firewall.
28. Install A/C switch box (5) and four screws (6) on bracket (7).

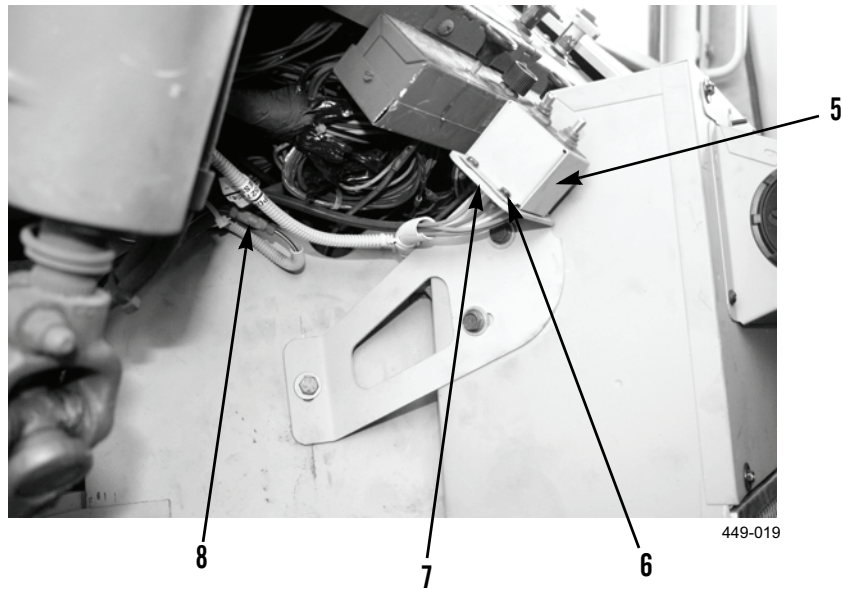

29. Connect ignition wire (4) (white wire) to ignition switch (3).

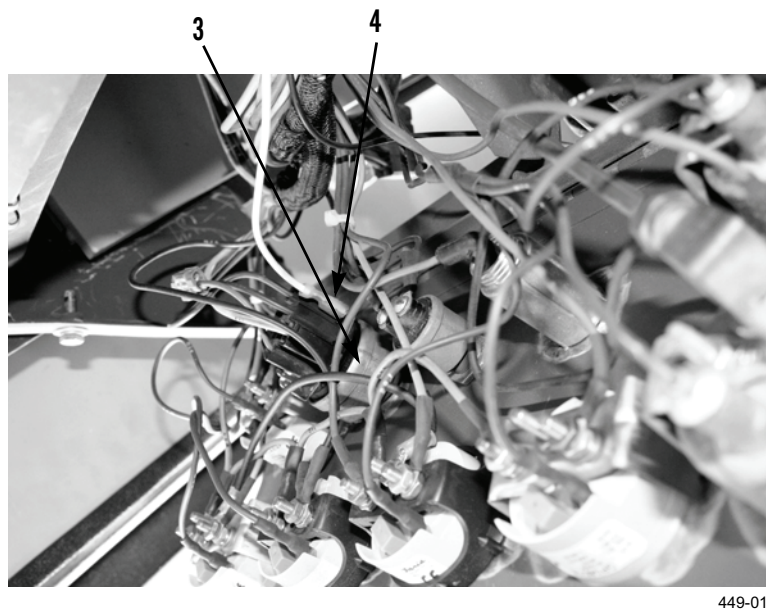

INSTALLATION - CONTINUED

30. Tighten four fasteners (1) and close instrument panel (2).
31. Close hood (TM 9-2320-273-10 and TM 9-2320-283-10).
32. Connect battery cables (TM 9-2320-273-20 and TM 9-2320-283-10).



449-017

END OF WORK PACKAGE

CHAPTER 6
SUPPORTING INFORMATION

SCOPE

This work package lists all publication indexes, forms, field manuals, technical bulletins, technical manuals, and other publications referenced in this bulletin and which apply to operation and maintenance of the Air Conditioning Kit.

PUBLICATION INDEXES

The following indexes should be consulted frequently for the latest changes or revisions and for new publications relating to material covered in this technical bulletin.

- Consolidated Army Publications and Forms Index. DA PAM 25-30
- Functional Users Manual for the Army Maintenance Management System (TAMMS) DA PAM 750-8

FORMS

NOTE

Refer to DA PAM 750-8, *Functional Users Manual for the Army Maintenance Management System (TAMMS)*, for instructions on the use of maintenance forms.

- Equipment Inspection and Maintenance Worksheet DA Form 2404, DA Form 5988-E
- Product Quality Deficiency Report. SF Form 368
- Recommended Changes to Publications and Blank Forms. DA Form 2028

FIELD MANUALS

- First Aid. FM 4-25.11

TECHNICAL BULLETINS

- CARC Spot Painting TB 43-0242
- Color, Marking, and Camouflage Painting of Military Vehicles, Construction Equipment,
and Materials Handling Equipment TB 43-0209

TECHNICAL MANUALS

- Direct Support and General Support Maintenance Manual for Truck,
Tractor, M915A1 Line-Haul TM 9-2320-283-34
- Direct Support and General Support Maintenance Manual for Truck,
M915, M916, M917, M918, M919, and M920 Line-Haul TM 9-2320-273-34
- Materials Used for Cleaning, Preserving, Abrading, and Cementing Ordnance Materiel and
Related Materials Including Chemicals TM 9-247
- Operator’s Manual for Truck, Tractor, M915A1 Line-Haul TM 9-2320-283-10
- Operator’s Manual for Truck, M915, M916, M917, M918, M919, and M920 Line-Haul TM 9-2320-273-10
- Procedures for Destruction of Tank-automotive Equipment to Prevent Enemy Use
(U. S. Army Tank-Automotive Command) TM 750-244-6
- Unit, Direct Support, and General Support Including Depot Maintenance RPSTL for Truck,
Tractor, M915A1 Line-Haul TM 9-2320-283-24P
- Organizational Maintenance Manual for Truck, Tractor, M915A1 Line-Haul TM 9-2320-283-20
- Unit, Direct Support, and General Support Including Depot Maintenance RPSTL for Truck,
M915, M916, M917, M918, M919, and M920 Line-Haul TM 9-2320-273-24P
- Organizational Maintenance Manual for Truck, Tractor, M915, M916, M917, M918,
M919, and M920 Line-Haul TM 9-2320-273-20

REFERENCES - CONTINUED

0022 00

OTHER PUBLICATIONS

Standard Abbreviations ASME Y14.38-1999
Army Medical Department Expendable/Durable Items CTA 8-100
Expendable/Durable Items (Except Medical, Class V, Repair Parts, and Heraldic Items) CTA 50-970

END OF WORK PACKAGE

THE ARMY MAINTENANCE SYSTEM

1. This introduction provides a general explanation of all maintenance and repair functions authorized at the two maintenance levels under the Two-Level Maintenance System concept.
2. The MAC immediately following this introduction designates overall authority and responsibility for the performance of maintenance functions on the identified end item or component. The application of the maintenance functions to the end item or component shall be consistent with the capacities and capabilities of the designated maintenance levels, which are shown in the *Maintenance Allocation Chart (MAC)* (WP 0024 00) in column (4) as:

Field - includes subcolumns:

C - Operator/Crew

O - Unit

F - Direct Support

Sustainment - includes subcolumns:

H - General Support

D - Depot

3. The tools and test equipment requirements (immediately following the MAC) list the tools and test equipment (both special tools and common tool sets) required for each maintenance function as referenced from the MAC.
4. The remarks (immediately following the tools and test equipment requirements) contain supplemental instructions and explanatory notes for a particular maintenance function.

MAINTENANCE FUNCTIONS

Maintenance functions are limited to and defined as follows:

1. **Inspect.** To determine the serviceability of an item by comparing its physical, mechanical, and/or electrical characteristics with established standards through examination (e.g., by sight, sound, or feel).
2. **Test.** To verify serviceability by measuring the mechanical, pneumatic, hydraulic, or electrical characteristics of an item and comparing those characteristics with prescribed standards on a scheduled basis, i.e., load testing of lift devices and hydrostatic testing of pressure hoses.
3. **Service.** Operations required periodically to keep an item in proper operating condition; e.g., to clean (includes decontaminate, when required), preserve, drain, paint, or replenish fuel, lubricants, chemical fluids, or gases.
4. **Adjust.** To maintain or regulate, within prescribed limits, by bringing into proper position, or by setting the operating characteristics to specified parameters.
5. **Align.** To adjust specified variable elements of an item to bring about optimum or desired performance.
6. **Calibrate.** To determine and cause corrections to be made or to be adjusted on instruments of test, measuring, and diagnostic equipment used in precision measurement. Calibration consists of comparisons of two instruments, one of which is a certified standard of known accuracy, to detect and adjust any discrepancy in the accuracy of the instrument being compared.
7. **Remove/Install.** To remove and install the same item when required to perform service or other maintenance functions. Installation may be the act of emplacing or seating a spare, repair part, or module (component or assembly) into position in a manner to allow the proper functioning of an equipment or system.
8. **Replace.** To remove an unserviceable item and install a serviceable counterpart in its place. Replacement is authorized by the MAC and the assigned maintenance level is shown as the third position code of the Source, Maintenance and Recoverability (SMR) code.
9. **Repair.** Repair is the application of maintenance services, including fault location/troubleshooting, removal/installation, disassembly/assembly procedures, and maintenance actions to identify troubles and restore serviceability to an item by correcting specific damage, fault, malfunction, or failure in a part, subassembly, module (component or assembly), end item, or system.

MAINTENANCE FUNCTIONS - CONTINUED**NOTE**

The following definitions are applicable to the "repair" maintenance function:

- Services - Inspecting, testing, service, adjustment, alignment, calibration, and/or replacement.
 - Fault location/troubleshooting - The process of investigating and detecting the cause of equipment malfunctioning; the act of isolating a fault within a system or Unit Under Test (UUT).
 - Disassembly/assembly - The step-by-step breakdown (taking apart) of a spare/functional group coded item to the level of its least component, assigned a SMR code for the level of maintenance under consideration (i.e., identified as maintenance significant).
 - Actions - Welding, grinding, riveting, straightening, facing, machining, and/or resurfacing.
10. **Overhaul.** That maintenance effort (service/action) prescribed to restore an item to a completely serviceable/operational condition as required by maintenance standards in appropriate technical publications. Overhaul is normally the highest degree of maintenance performed by the Army. Overhaul does not normally return an item to like new condition.
11. **Rebuild.** Consists of those services/actions necessary for the restoration of unserviceable equipment to a like new condition in accordance with original manufacturing standards. Rebuild is the highest degree of materiel maintenance applied to Army equipment. The rebuild operation includes the act of returning to zero those age measurements (hours/miles, etc.) considered in classifying Army equipment/components.

EXPLANATION OF COLUMNS IN THE MAC, TABLE 1

1. **Column (1) - Group Number.** Column (1) lists Group numbers, the purpose of which is to identify maintenance significant components, assemblies, subassemblies, and modules with the Next Higher Assembly (NHA).
2. **Column (2) - Component/Assembly.** Column (2) contains the item names of components, assemblies, subassemblies, and modules for which maintenance is authorized.
3. **Column (3) - Maintenance Function.** Column (3) lists the functions to be performed on the item listed in Column (2). (For a detailed explanation of these functions refer to "Maintenance Functions" outlined above).
4. **Column (4) - Maintenance Level.** Column (4) specifies each level of maintenance authorized to perform each function listed in column (3), by indicating work time required (expressed as man hours in whole hours or decimals) in the appropriate subcolumn. This work time figure represents the active time required to perform that maintenance function at the indicated level of maintenance. If the number or complexity of the tasks within the listed maintenance function varies at different maintenance levels, appropriate work time figures are to be shown for each level. The work time figure represents the average time required to restore an item (assembly, subassembly, component, module, end item, or system) to a serviceable condition under typical field operating conditions. This time includes preparation time (including any necessary disassembly/assembly time), troubleshooting/fault location time, and quality assurance time in addition to the time required to perform the specific tasks identified for the maintenance functions authorized in the MAC. The symbol designations for the various maintenance levels are as follows:

Field:

C - Operator/Crew Maintenance
O - Unit Maintenance
F - Direct Support Maintenance

Sustainment:

H - General Support Maintenance
D - Depot Maintenance

EXPLANATION OF COLUMNS IN THE MAC, TABLE 1 - CONTINUED**NOTE**

The "L" maintenance level is not included in column (4) of the MAC. Functions to this level of maintenance are identified by a work time figure in the "H" column of column (4), and an associated reference code is used in the REMARKS CODE column (6). This code is keyed to the remarks, and the SRA complete repair application is explained there.

5. **Column (5) - Tools and Equipment Reference Code.** Column (5) specifies, by code, common tool sets (not individual tools), common Test, Measurement, and Diagnostic Equipment (TMDE), special tools, special TMDE, and special support equipment required to perform the designated function. Codes are keyed to the entries in the tools and test equipment table.
6. **Column (6) - Remarks Code.** When applicable, this column contains a letter code, in alphabetical order, which is keyed to the remarks table entries (Table 3).

EXPLANATION OF COLUMNS IN THE TOOLS AND TEST EQUIPMENT REQUIREMENTS, TABLE 2

1. **Column (1) - Tool or Test Equipment Reference Code.** The tool and test equipment reference code correlates with a code used in column (5) of the MAC.
2. **Column (2) - Maintenance Level.** The lowest level of maintenance authorized to use the tool or test equipment.
3. **Column (3) - Nomenclature.** Name or identification of the tool or test equipment.
4. **Column (4) - National Stock Number (NSN).** The NSN of the tool or test equipment.
5. **Column (5) - Tool Number.** The manufacturer's part number, model number, or type number.

EXPLANATION OF COLUMNS IN THE REMARKS, TABLE 3

1. **Column (1) - Remarks Code.** The code recorded in column (6) of the MAC.
2. **Column (2) - Remarks.** This column lists information pertinent to the maintenance function being performed as indicated in the MAC.

END OF WORK PACKAGE

MAINTENANCE ALLOCATION CHART (MAC)

0024 00

Table 1. MAC for the Air Conditioning Kit.

(1) GROUP NUMBER	(2) COMPONENT/ ASSEMBLY	(3) MAINTENANCE FUNCTION	(4) MAINTENANCE LEVEL				(5) TOOLS AND EQUIPMENT REF CODE	(6) REMARKS CODE	
			FIELD		SUSTAINMENT				
			UNIT		DS	GS			DEPOT
			C	O	F	H			D
33	SPECIAL PURPOSE KITS								
3307	Air Conditioning Kit:	Install			16		1,2,3,4,5,6,7,8, 9,10,11,12		
	Vehicle Preparation				1.0				
	A/C System	Recovery			1.0		5,10,11		
		Evacuation			1.0		5,10,11		
		Charging			1.0		5,10,11		
	Compressor	Inspect	0.2						
		Install			2.0		5,10,11		
		Replace			1.5		5,10,11		
	Evaporator/Blower Unit	Inspect	0.2					A	
		Repair			1.0		10	C	
		Install			2.0		5,6,7,9,10,11		
		Replace			1.5		5,6,7,9,10,11		
	Condenser Unit	Inspect	0.2					A	
		Install			2.0		5,7,9,10,11,12		
		Replace			1.5		5,7,9,10,11,12		
	Receiver/Dryer	Inspect	0.2						
		Install			2.0		5,10,11		
		Replace			1.5		5,10,11		
	A/C Hose	Inspect	0.2					A	
		Install			2.0		5,10,11		
		Replace			1.0		5,10,11		
	A/C Wiring Harness	Inspect	0.2					A	
		Install			2.0		10		
		Replace			1.0		10		

MAINTENANCE ALLOCATION CHART (MAC) - CONTINUED

0024 00

Table 2. Tools and Test Equipment Requirements for the Air Conditioning Kit.

(1) ITEM NO.	(2) MAINTENANCE LEVEL	(3) ITEM NAME	(4) NATIONAL STOCK NUMBER	(5) PART NUMBER/ CAGEC
1	O	Clamp, C: 10 in. Size	5120-00-203-6432	5120-00-203-6432 (08292)
2	O	Dispenser, Sealant	5120-00-679-5655	101 (06798)
3	O	Drill Set, Twist: 33/64 to 3/4 in. in 1/64 in. Increments	5133-00-596-8088	B94.11M (05047)
4	O	Link, Bearing (Lifting)	5120-01-451-1401	1387575 (11083)
5	F	Reclaimer, Refrigerant	4250-01-359-0393	SS90-R134-50/60
6	O	Shop Equipment, Automotive Maintenance and Repair: Organizational Maintenance, Common No. 1, Less Power	4910-00-754-0654	SC 4910-95CLA74 (19204)
7	O	Shop Set, Welding Field Maintenance Post, Camp and Station, Set B	4940-00348-7596	SC3470-95CLA11 (19204)
8	O	Sling, Nylon	2835-01-078-2081	4-8FTX2IN (91796)
9	O	Tool Kit, General Mechanic's Automotive	5180-01-454-3787	12B470000 (59678)
10	F	Tool Kit, Refrigeration Equipment (available in SC 5180-95-N18)	5180-00-596-1474	SC 5180-90-CL-N18
11	O	Wrench Set, Torx	5120-01-529-2707	05253

Table 3. Remarks for the Air Conditioning Kit.

(1) REMARKS CODE	(2) REMARKS
A	Refer to Operator <i>PMCS</i> .
B	Service by cleaning ballistic glass.
C	Limited Repair Authorized

END OF WORK PACKAGE

EXPENDABLE AND DURABLE ITEMS LIST

0025 00**SCOPE**

This technical bulletin lists expendable and durable items you will need to install, operate and maintain the Air Conditioning Kit. This listing is for informational purposes only and is not authority to requisition the listed items. These items are authorized to you by CTA 50-970, *Expendable/Durable Items (Except Medical, Class V, Repair Parts, and Heraldic Items)*, or CTA 8-100, *Army Medical Department Expendable/Durable Items*.

EXPLANATION OF COLUMNS

1. **Column (1) - Item Number.** This number is assigned to the entry in the listing and is referenced in the narrative instructions to identify the item [e.g., Apply Sealing Compound, Urethane (Item 11, WP 0025 00)].
2. **Column (2) - Level.** This column identifies the lowest level of maintenance that requires the listed item.
 - C - Operator/Crew
 - O - Unit Maintenance
3. **Column (3) - National Stock Number.** This is the National Stock Number assigned to the item which you can use to requisition it.
4. **Column (4) - Description, CAGEC, and Part Number.** This provides the other information you need to identify the item.
5. **Column (5) - Unit of Measure (U/M).** This column shows the physical measurement or count of an item, such as gallon, dozen, gross, etc.

Table 1. Expendable and Durable Items List for Air Conditioning Kit.

(1) ITEM NUMBER	(2) LEVEL	(3) NATIONAL STOCK NUMBER	(4) DESCRIPTION, CAGEC, AND PART NUMBER	(5) U/M
1	O		Adhesive, Thread (05972) 242	
		8040-01-250-3969	50 Milliliter Bottle	BT
2	C		Cleaning Compound, Solvent, Type III (81349) MIL-PRF-680	
		6850-01-474-2318	1 Gallon Can	CN
		6850-01-474-2320	5 Gallon Can	CN
		6850-01-474-2321	55 Gallon Drum	DR
3	O		Cloth, Abrasive (80204) ANSI B74.18	
		5350-00-584-4654	50 Sheet Package	PG
4	C		Compound, Antiseize (05972) 051135-08609	
		8030-00-251-3980	1 Pound Can	CN
5	C		Detergent, General Purpose, Liquid (83421) 7930-00-282-9699	
		7930-00-282-9699	1 Gallon Can	CN
		9140-00-286-5294	Bulk	GL
		9140-00-286-5295	5 Gallon Can	CN
		9140-00-286-5296	55 Gallon Drum	DR
6	C	6810-01-075-5546	Isopropyl Alcohol (97403) 13222E0694	BT
7	C		Oil, Lubricating, OE/HDO-10 (81349) MIL-PRF-2104	
		9150-00-189-6727	1 Quart Can	CN
		9150-00-186-6668	5 Gallon Can	CN
		9150-00-191-2772	55 Gallon Drum	DR
8	F	9150-01-524-4276	Oil, Lubricating, Refrigerant Compressor (62534) RD-5-7103-OP	BT
9	C		Rag, Wiping (64067) A-A-431	
		7920-00-205-1711	50 Pound Bale	BL
10	F	6830-01-439-0614	Refrigerant, (4V886) R-134a	cyl

EXPENDABLE AND DURABLE ITEMS LIST - CONTINUED

0025 00

Table 1. Expendable and Durable Items List for Air Conditioning Kit - Continued.

(1) ITEM NUMBER	(2) LEVEL	(3) NATIONAL STOCK NUMBER	(4) DESCRIPTION, CAGEC, AND PART NUMBER	(5) U/M
11	O	8030-01-320-4710	Sealing Compound, Urethane (52157) 051135-08609 10.5 Ounce Cartridge	CA
12	O	5975-01-379-4997	Strap, Tiedown Electrical Components (06383) PLT35-C-O Package of 100	PK
13	O	9905-00-537-8954	Tag, Marker (64067) 9905-00-537-8954 Bundle of 50	BD
14	O	7510-00-473-9513	Tape, Pressure Sensitive Adhesive (81349) MIL-T-23397 60 Yard Roll	RL
15	O	4120-01-523-4007	Tape, Refrigeration	EA

END OF WORK PACKAGE

SCOPE

This technical bulletin lists standard torque values and provides general information for applying torque. Special torque values and tightening sequences are indicated in the maintenance procedures for applicable components.

GENERAL

1. Always use torque values listed in Tables 1 and 2 when a maintenance procedure does not give a specific torque value.
 - a. Table 1 provides torque limits for SAE standard fasteners.
 - b. Table 2 provides torque limits for metric fasteners.
2. Unless otherwise indicated, standard torque tolerance shall be ± 10 percent.
3. Torque values listed are based on clean, dry threads. Reduce torque by 10 percent when engine oil is used as a lubricant. Reduce torque by 20 percent if new plated capscrews are used.
4. If the maintenance procedures do not specify a tightening order, use the following guides:
 - a. Unless otherwise specified, lubricate threads of fasteners with clean oil (OE/HDO-10).
 - b. When tightening fasteners above 30 lb-ft (41 Nm), use the torque pattern but only tighten to 70 percent of final value (multiply final value by 0.7). Repeat pattern until final value is reached.
 - c. Tighten circular patterns using circular torque pattern and tighten straight patterns using straight torque pattern.

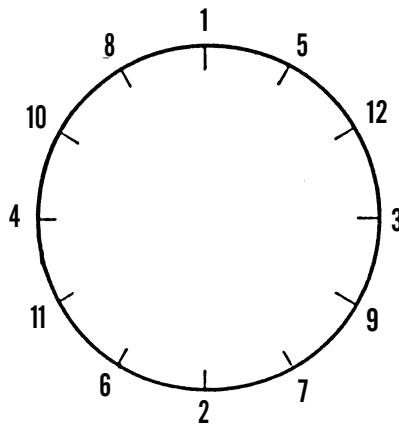
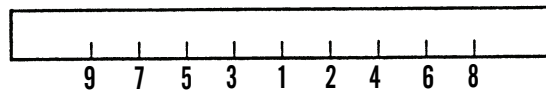
**CIRCULAR TORQUE PATTERN****STRAIGHT TORQUE PATTERN****CAUTION**

If replacement capscrews are of higher grade than originally supplied, use torque specifications for the original. This will prevent equipment damage due to overtightening.

TORQUE LIMITS - CONTINUED

0026 00

Table 1. Torque Limits - SAE Standard Fasteners.



CURRENT USAGE	MUCH USED	MUCH USED	USED AT TIMES	USED AT TIMES
QUALITY OF MATERIAL	INDETERMINATE	MINIMUM COMMERCIAL	MEDIUM COMMERCIAL	BEST COMMERCIAL
SAE Grade Number	1 or 2	5	6 or 7	8
Cap Screw Head Markings				
Manufacturer's marks may vary				
These are all SAE Grade 5 (3 line)				
CAPSCREW BODY SIZE IN. - THREAD	TORQUE LB-FT (NM)	TORQUE LB-FT (NM)	TORQUE LB-FT (NM)	TORQUE LB-FT (NM)
1/4 20 28	5 (7) 6 (8)	8 (11) 10 (14)	10 (14)	12 (16) 14 (19)
5/16 18 24	11 (15) 13 (18)	17 (23) 19 (26)	19 (26)	24 (33) 27 (37)
3/8 16 24	18 (24) 20 (27)	31 (42) 35 (47)	34 (46)	44 (60) 49 (66)
7/16 14 20	28 (38) 30 (41)	49 (66) 55 (75)	55 (75)	70 (95) 78 (106)
1/2 13 20	39 (53) 41 (56)	75 (102) 85 (115)	85 (115)	105 (142) 120 (163)
9/16 12 18	51 (69) 55 (75)	110 (149) 120 (163)	120 (163)	155 (210) 170 (231)
5/8 11 18	83 (113) 95 (129)	150 (203) 170 (231)	167 (226)	210 (285) 240 (325)
3/4 10 16	105 (142) 115 (156)	270 (366) 295 (400)	280 (380)	375 (508) 420 (569)
7/8 9 14	160 (217) 175 (237)	395 (536) 435 (590)	440 (597)	605 (820) 675 (915)
1 8 14	235 (319) 250 (339)	590 (800) 660 (895)	660 (895)	910 (1,234) 990 (1,342)

Table 2. Torque Limits - Metric Fasteners.

TORQUE VALUES FOR METRIC THREAD FASTENERS WITH LUBRICATED* OR PLATED THREADS†				
Thread Diameter-Pitch				
	Class 8.8 Bolt	Class 8 Nut	Class 10.9 Bolt	Class 10 Nut
	Torque: lb-ft (Nm)		Torque: lb-ft (Nm)	
M6	5 (7)		7 (9)	
M8	12 (16)		17 (23)	
M8 x 1	13 (18)		18 (24)	
M10	24 (33)		34 (46)	
M10 x 1.25	27 (37)		38 (52)	
M12	42 (57)		60 (81)	
M12 x 1.5	43 (58)		62 (84)	
M14	66 (89)		95 (129)	
M14 x 1.5	72 (98)		103 (140)	
M16	103 (140)		148 (201)	
M16 x 1.5	110 (149)		157 (213)	
M18	147 (199)		203 (275)	
M18 x 1.5	165 (224)		229 (310)	
M20	208 (282)		288 (390)	
M20 x 1.5	213 (313)		320 (434)	
M22	283 (384)		392 (531)	
M22 x 1.5	315 (427)		431 (584)	
M24	360 (488)		498 (675)	
M24 x 2	392 (531)		542 (735)	
M27	527 (715)		729 (988)	
M27 x 2	569 (771)		788 (1,068)	
M30	715 (969)		990 (1,342)	
M30 x 2	792 (1,074)		1096 (1,486)	

* All plated and unplated fasteners should be coated with oil before installation.

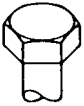
† Use these torque values if either the bolt or nut is lubricated or plated (zinc-phosphate conversion-coated, cadmium-plated, or waxed).

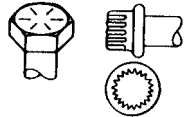
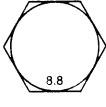
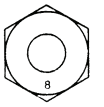
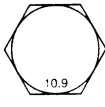
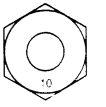
END OF WORK PACKAGE

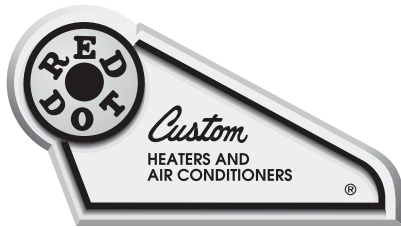

Air Conditioner for M915 A0/A1 Truck

RD-2-4530-0

INSTALLATION INSTRUCTIONS

Install refrigerant compressor per instructions provided with compressor mount kit.

CAUTION:

Edges of sheet metal can be sharp! Wear gloves to protect hands from cuts when handling condenser assembly and evaporator assembly.

Wear safety goggles when using power tools or when working with pressurized systems such as refrigerant lines.

Before starting installation review parts list included in kit to verify that all required parts needed for installation were received.

TOOLS REQUIRED

SYSTEM INSTALLATION

- 1/8", 1/4", and 5/16" drill bits
- 1 1/4" hole saw
- Power drill that will accept drill bits and hole saw listed above.
- #2 Phillips head screwdriver bit for drill
- # 2 Phillips head screwdriver
- Flat blade screwdriver
- Ratchet
- 5" extension
- 5/16" nut driver
- 3/8" open end wrench
- 7/16" open end wrench
- 9/16" open end wrench
- 5/8" open end wrench
- 3/4" open end wrench
- 7/8" open end wrench
- 1 1/16" open end wrench
- 3/8" socket
- 3/4" socket
- 10mm open end wrench
- 13mm open end wrench
- 10mm socket
- 13mm socket
- 16mm socket
- Utility knife or pocket knife
- Scissors
- Wire cutters

- Wire strippers
- Masking tape
- Ratchet
- 1/2" Ratchet or breaker bar
- 3/4" open end wrench
- 7/8" open end wrench
- 15/16" open end wrench or socket
- 3/4" socket
- 17mm open end wrench

COMPRESSOR

- Ratchet
- 1/2" Ratchet or breaker bar
- 3/4" open end wrench
- 7/8" open end wrench
- 15/16" open end wrench or socket
- 3/4" socket
- 16mm socket
- 17mm open end wrench

REFRIGERANT CHARGING EQUIPMENT

- Charging gauges and scale or charging station
- Vacuum pump
- R-134a refrigerant



COMPRESSOR MOUNTING

Install refrigerant compressor per instructions provided with compressor mount kit.

CONDENSER MOUNTING



1. Remove headliner. See Figure 1

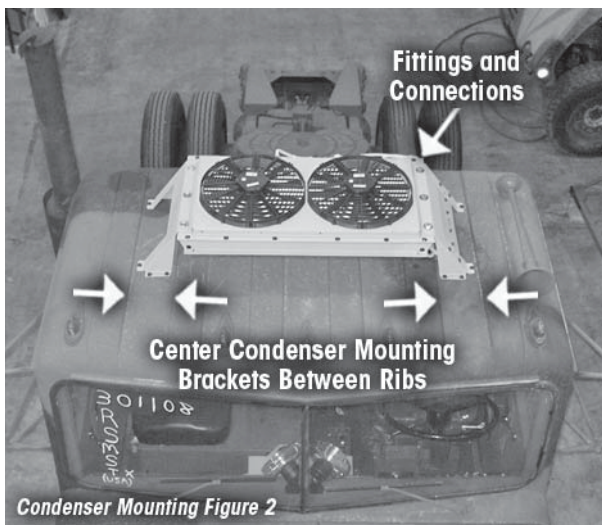

2. Rest condenser unit on roof with refrigerant fittings and wire connectors on driver's side facing towards the rear of vehicle. See Figure 2

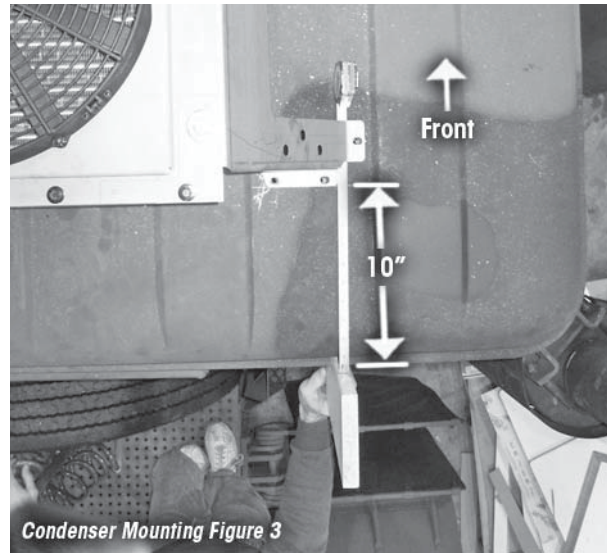

3. Position condenser so that the mounting pads are centered between ribs and that the rear edge of the mounting pad is 10 inches from the back wall of cab. See Figure 3
4. Using a $\frac{5}{16}$ " drill bit, drill through the roof using the holes in the mounting pads as a guide.
(CAUTION: drill carefully so as not to entangle drill bit in cab insulation)

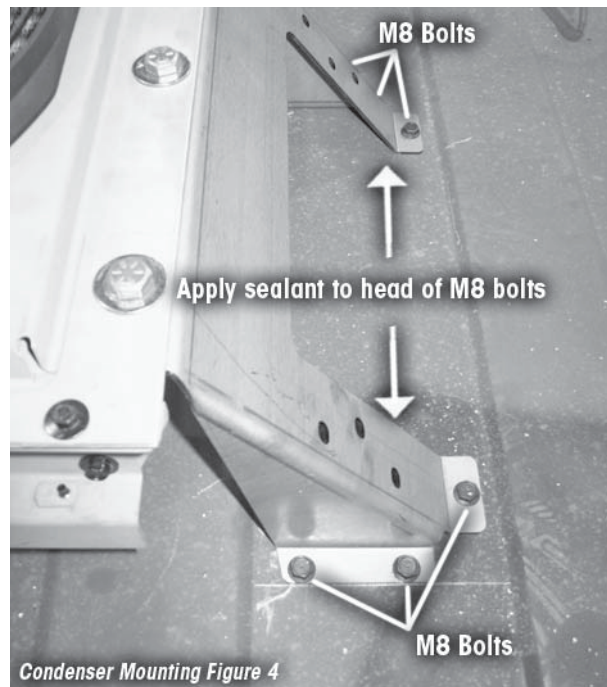

5. Locate condenser mount hardware kit A; In RD-2-4529-0 install kit. Lift drivers side condenser mount above roof and apply a liberal amount of sealant from kit A around each mount hole in roof. Repeat for passenger side mount. Install twelve M8x25mm bolts through mount and roof. (Apply sealant to head of each bolt prior to installation.) Install twelve flat washers and nylon lock nuts on inside of roof and tighten. See Figure 4
6. Reinstall headliner.

EVAPORATOR AND DRIER MOUNTING

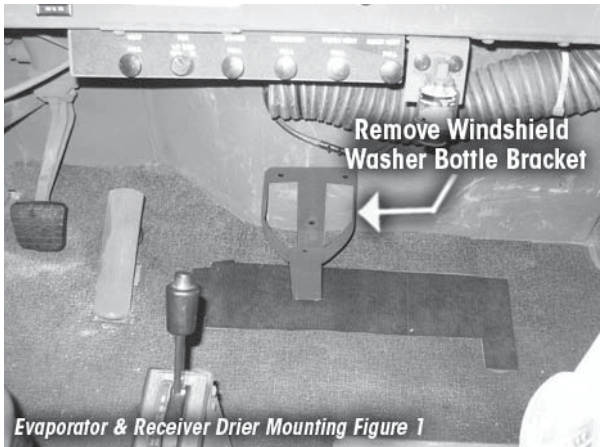

1. Remove and save windshield washer bottle. (Mark hoses for later reinstallation) Disconnect hoses at double tee fitting, lift bottle from bracket. Remove bracket from firewall. Save bracket and hardware. See figure 1

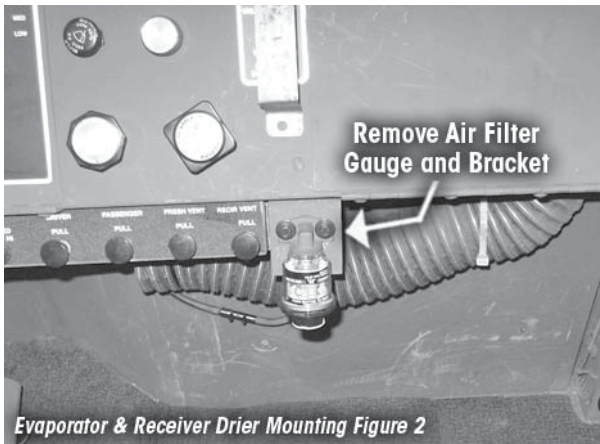

2. Remove and save air filter gauge. Disconnect hose from fitting on rear of gauge, then remove the two screws holding the gauge bracket to the under side of dash panel. (Save gauge and bracket) After removing bracket, reinstall the two mounting screws to secure ground wires. See figure 2

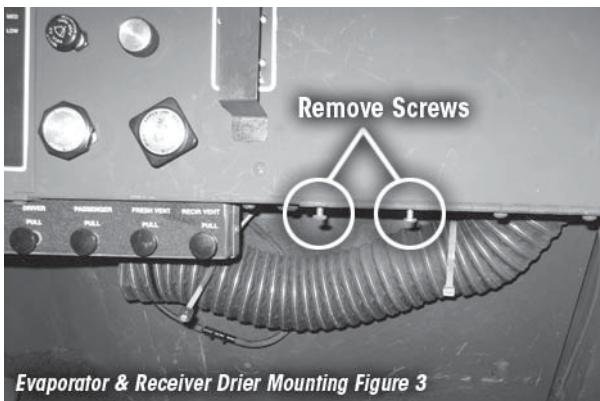

3. Remove the two left screws holding the circuit breaker door hinge to the underside of dash panel. See Figure 3

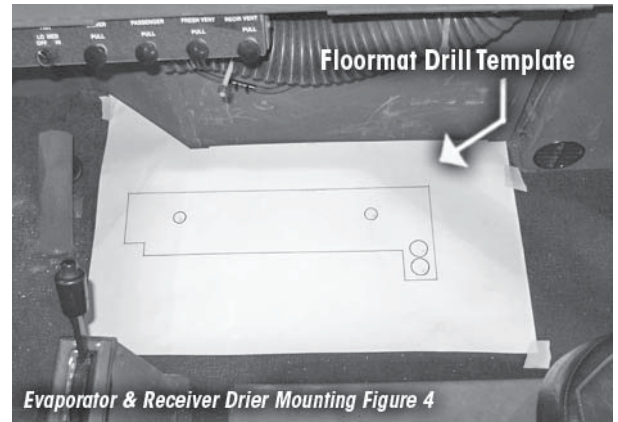

4. Locate floor mat template in A/C kit RD-2-4530-0, cut template as required and position in cab with front edge of template lined up on firewall. Tape into position. See Figure 4



5. Using a 1/4" (.250) drill bit, drill pilot holes through the center of the four holes on the template. (Look under vehicle floor to make sure nothing will be damaged prior to drilling holes) See Figure 5

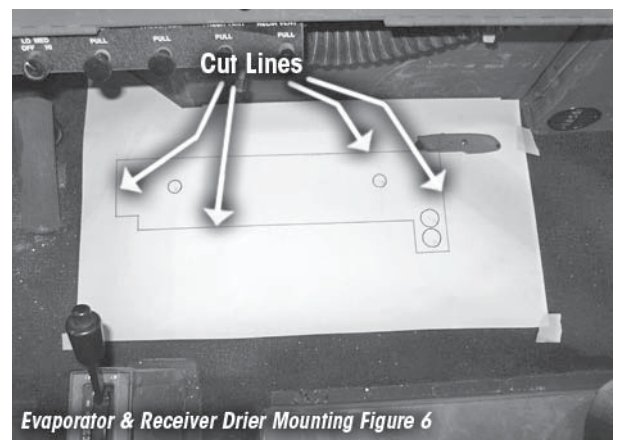

6. Using a utility knife, razor blade, pocket knife, etc. cut floor mat by following cut line on mat template. When cut has been completed, remove mat template and floor mat from cut area. See Figure 6

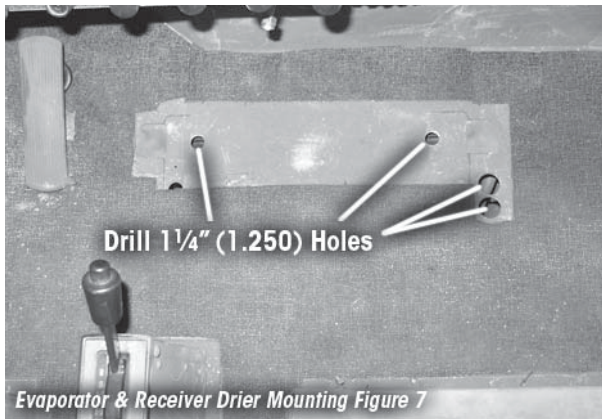

7. Using an 1 1/4" (1.250") hole saw, drill four holes in floor as identified on template, using the previously drilled 1/4" (.250") holes as a guide. See Figure 7

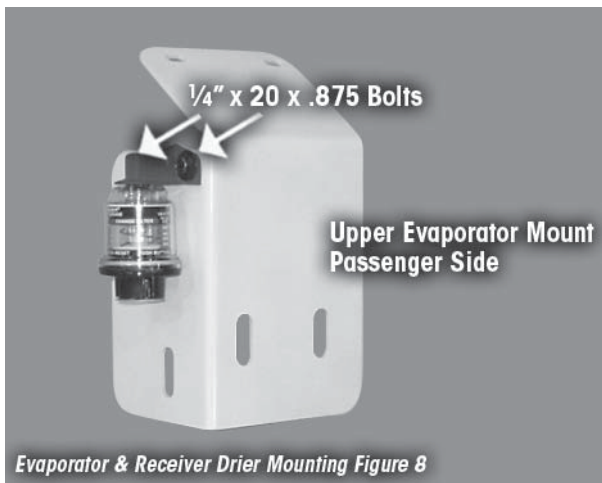

8. Locate passenger side upper evaporator mount bracket RD-2-4484-0 and previously removed air filter gauge. Remove air filter gauge from its bracket. Using two 1/4"x.875 bolts and two nylon lock nuts from kit C, install air filter gauge onto upper evaporator bracket. See Figure 8

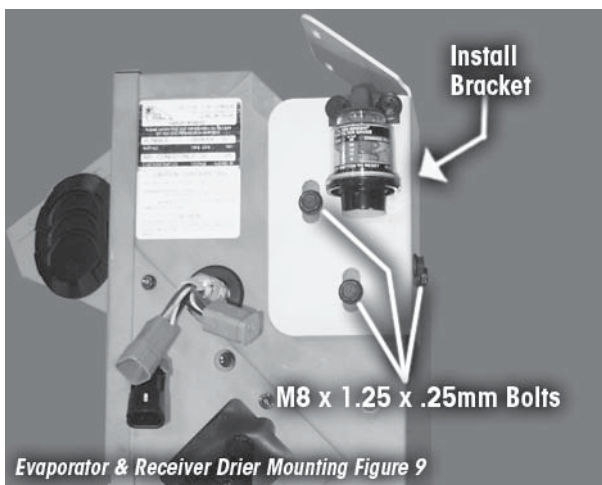

9. Using four M8x25mm bolts found in kit B, install the upper evaporator bracket onto the evaporator unit. (Do not tighten bolts at this time) See Figure 9
10. Locate drain hose, rubber duck bill grommets, plastic couplers, and 4" nylon tie wraps from the Drain Hose Kit located within the RD-2-4529-0 Installation Kit.

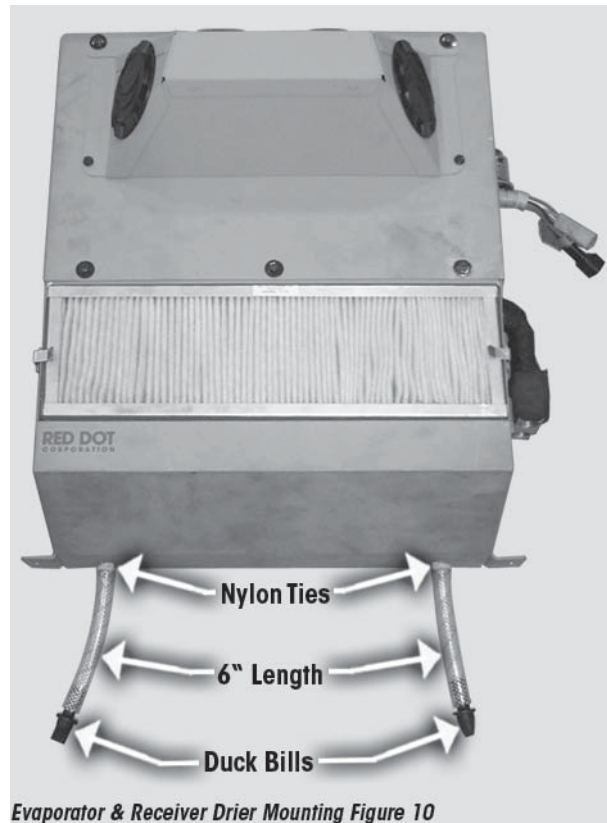

Evaporator & Receiver Drier Mounting Figure 10

11. Cut two 6" pieces of hose and attach one rubber duck bill grommet to each hose using plastic coupler. Push drain hoses onto drain tubes on bottom of evaporator unit. Secure the hose to the fitting using a 4" nylon tie wrap. See Figure 10

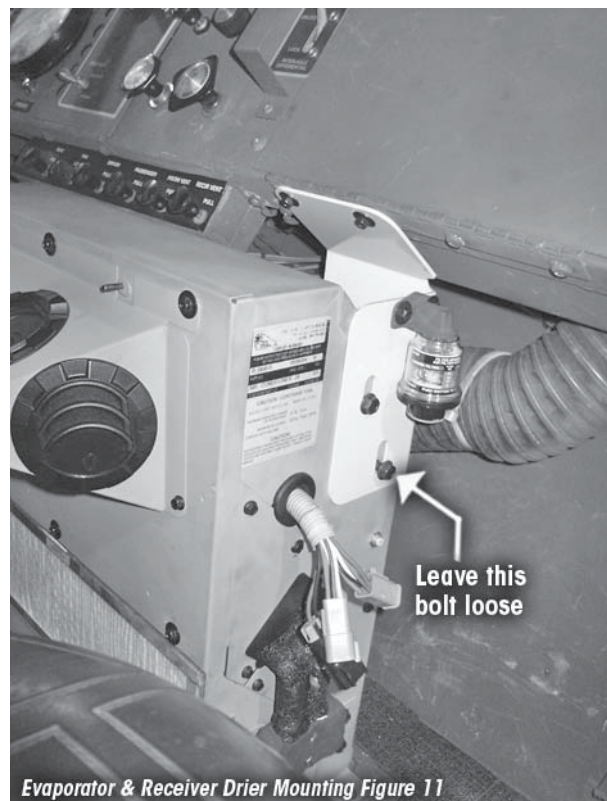

Evaporator & Receiver Drier Mounting Figure 11

12. Place evaporator unit into position on floor, making sure that the duck bill grommets and drain hoses pass freely through drain holes in floor. Locate two 1/4"x.875 bolts from

Kit C. Slide upper evaporator mount bracket up until the two top mounting holes line up with the two bolt holes in the circuit breaker panel hinge. Install the two 1/4" bolts through bracket and into the threaded holes in the hinge. Straighten evaporator unit with firewall and square to floor. Tighten the two rear and upper side evaporator bracket mounting bolts, leaving the bottom side bolt loose at this time. See Figure 11

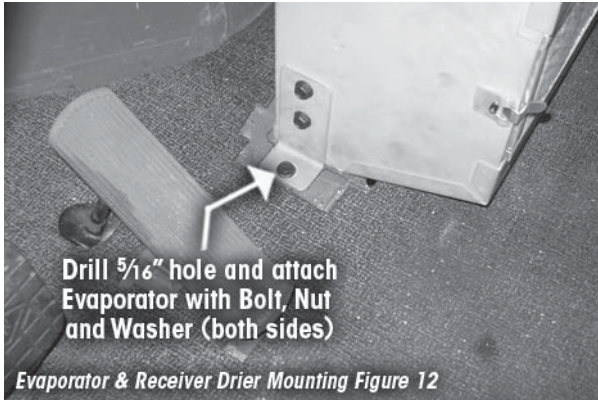

- 13.** With evaporator unit straight and square, use a 5/16" (.312") drill bit and drill through floor using bolt hole in bottom evaporator mount as a drill guide. Drill both driver and passenger sides. Locate two M8x25mm bolts, two flat washers, and two nylon lock nuts from kit B. Insert bolts through bottom evaporator mount and floor. From under vehicle attach one flat washer and locknut to each bolt and tighten. See Figure 12

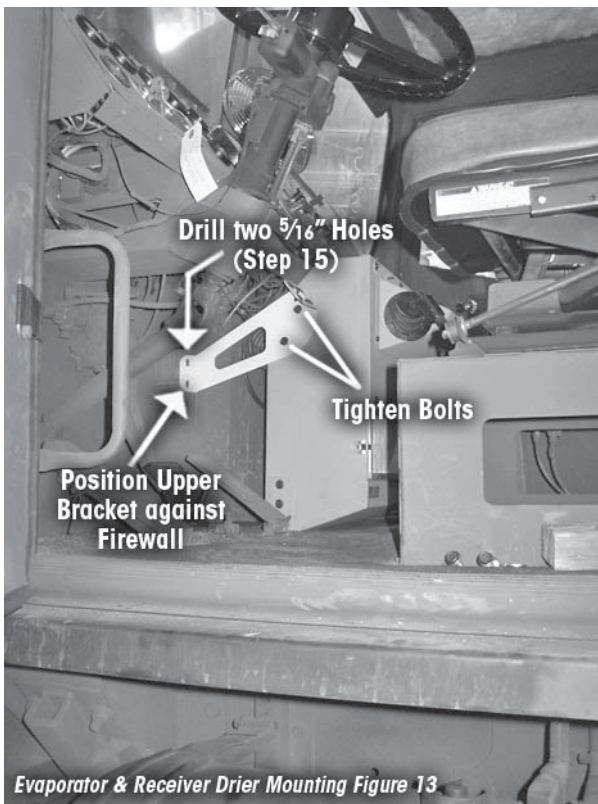

- 14.** Locate drivers side upper evaporator mount bracket RD-2-7798-0. Locate four M8x25mm bolts, two flat washers, and two nylon lock nuts from kit B. Loosely attach upper mount bracket to evaporator unit using two M8x25mm bolts. Position bracket so that forward flange of bracket rests flat

against the firewall. Tighten bolts holding mount bracket to evaporator unit. See Figure 13

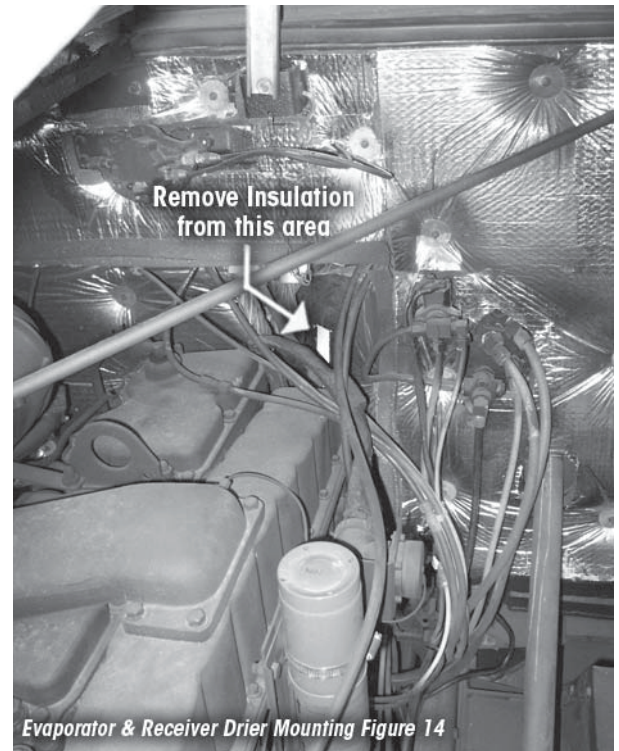

- 15.** Using a 5/16" (.312") drill bit, drill through firewall using the two bolt holes in forward flange of mount bracket as a guide. Insert two M8x25mm bolts from kit B through mount bracket and firewall. From engine compartment, locate where the two bolts just inserted protrude from insulation. Using a utility knife, pocket knife, etc. cut insulation foam away from around bolts to allow room for flat washers and locknuts to be installed. Install flat washers and nylon lock nuts and tighten. See figure 14



- 16.** Locate "RD-2-4532-0 Kit-Drier" and RD-4-6096-0 Drier bracket. Remove screw caps from ports on top of receiver/drier. Lubricate O-rings with mineral oil and attach pressure

switches to ports. Switches can be installed in either port. See figure 15

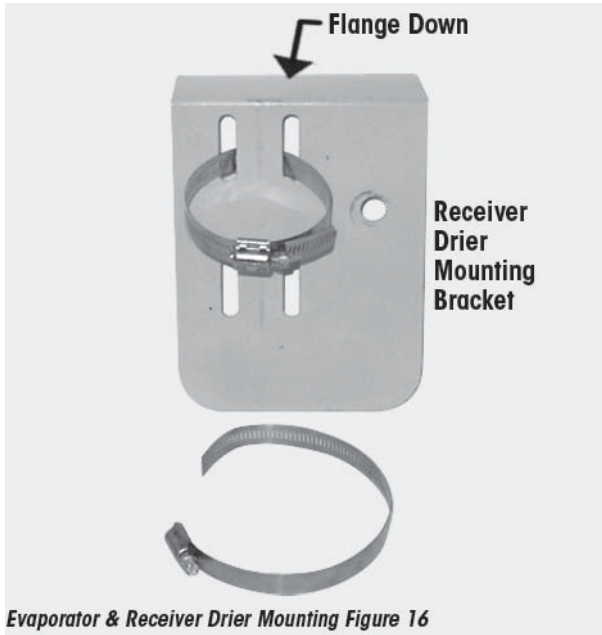

Evaporator & Receiver Drier Mounting Figure 16

17. Install receiver/drier to mounting bracket using the two large hose clamps provided. Pre-bend end of clamp to ease installation as shown in figure 16

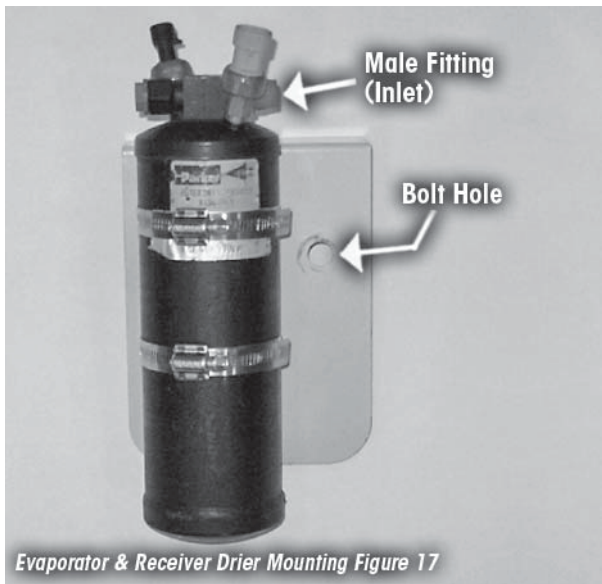

Evaporator & Receiver Drier Mounting Figure 17

18. Position drier with inlet (male fitting) facing towards bolt hole in mount bracket. Tighten clamps. See figure 17

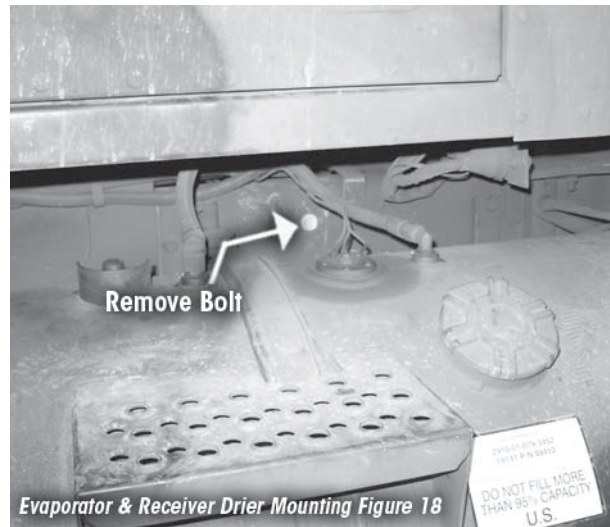

Evaporator & Receiver Drier Mounting Figure 18

19. Remove and save $\frac{1}{2}$ " (.500") bolt located approximately 6" aft of center fuel tank mounting bracket on drivers' side frame rail. See Figure 18

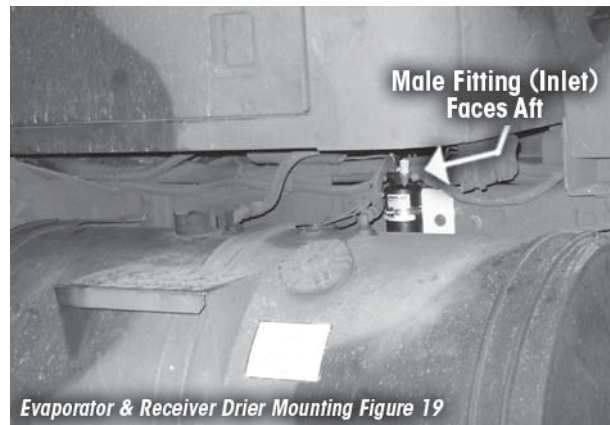

Evaporator & Receiver Drier Mounting Figure 19

20. Place flange of receiver/drier mounting bracket on top of driver's side frame rail and position so that holes in mount and frame rail line up. Insert previously removed $\frac{1}{2}$ " bolt, making sure that wiring bracket on inside of frame rail is in place. Attach nut and tighten. See Figure 19

HOSE ROUTING

Trim Grommets



Hose Routing Figure 1

1. Locate two cone grommets in hose kit within RD-2-4529-0 install kit. Trim end of both grommets to achieve a snug fit around #12 hose. Trim grommet flange flush on one side to allow clearance. See Figure 1



Hose Routing Figure 2

2. Install grommets in cab floor in previously drilled 1 1/4" (1.250") diameter holes. See Figure 2

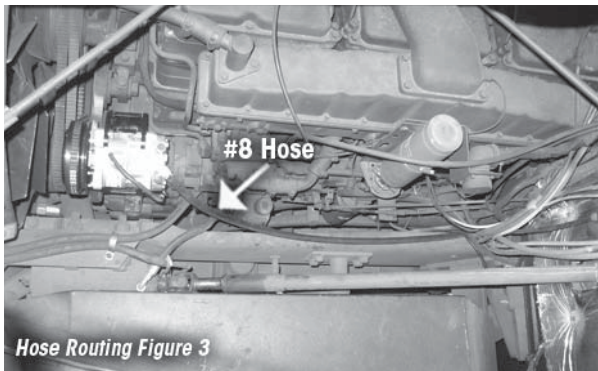

Hose Routing Figure 3

3. Tape closed both ends of hoses to keep debris out of hose. Route #8 hose from compressor along top of driver's side frame rail to rear of cab. Continue up rear wall of cab to condenser. Allow extra hose at each end. Do not cut or connect fittings at this time. See Figure 3 and 5.

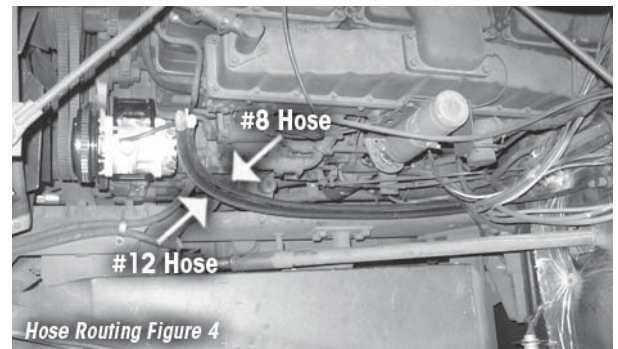

Hose Routing Figure 4

4. From inside cab, route #12 hose through rear cone grommet in cab, across the top of the transmission to driver's side frame rail. Continue forward on top of frame rail along side of #8 hose to the compressor. Allow extra hose at each end. Do not cut hose or connect fittings at this time. See Figure 4
5. Locate #6 hose (found in A/C kit). Cut a piece 6 feet long. Save remaining hose. (Tape closed both ends of hose to keep debris out of hose.) Route the 6 foot section of #6 hose through front cone grommet in cab, across top of transmission to driver's side frame rail. Continue back over top of frame rail to outlet (forward female fitting) of receiver/drier. Allow extra hose at each end.

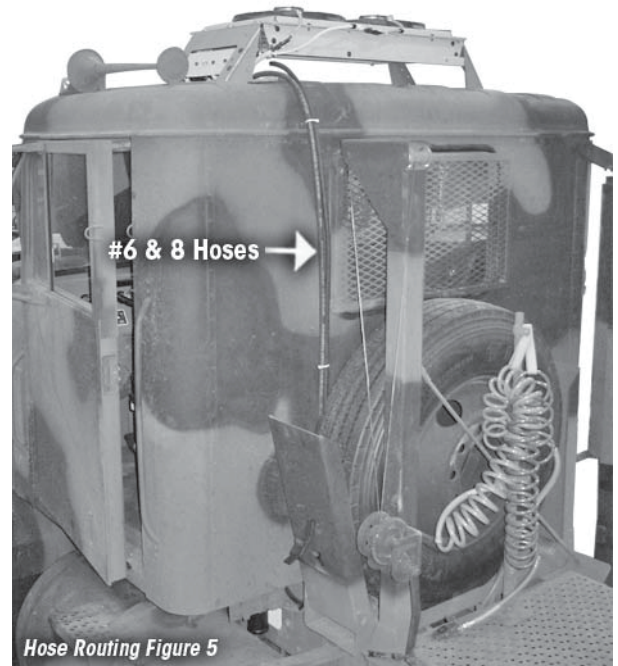

Hose Routing Figure 5

6. With remaining #6 hose, continue from inlet of receiver/drier (male fitting) up back wall of cab following #8 hose to condenser. Allow extra hose at each end and secure to #8 hose using nylon ties. See Figure 5
7. Secure hoses under cab of vehicle and along frame rail using nylon ties. Avoid high heat sources, sharp edges and moving parts of vehicle.

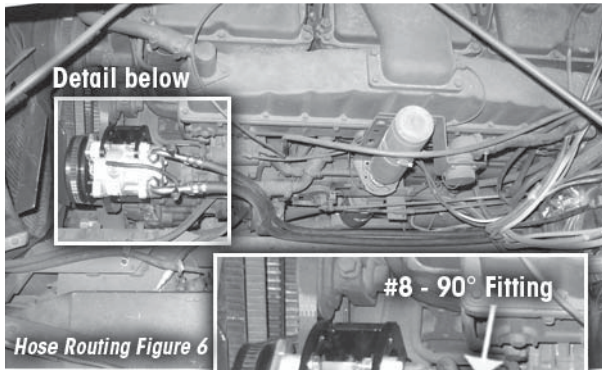

- 8.** After securing hoses under vehicle, locate #8 female 90° fitting with charge port, and #10-12 female 90° fitting with charge port, within A/C fittings kit RD-2-4531-0. Lubricate O-rings and install on to compressor. (Hand tight only) Trim ends of hoses to length and crimp onto fittings. Lubricate fittings prior to inserting into hose. Tighten fittings. See Figure 6 (See page 9 for hose crimping instructions.)

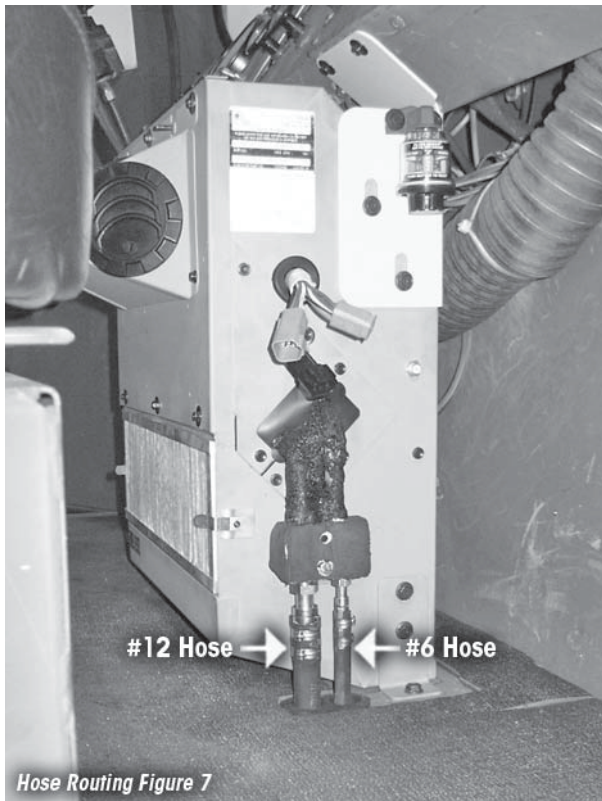

- 9.** Lubricate o-rings and install straight #6 and #10-12 male fittings to expansion valve on evaporator unit. (Hand tight only) Trim ends of hoses to length and crimp onto fittings. Tighten fittings. See Figure 7

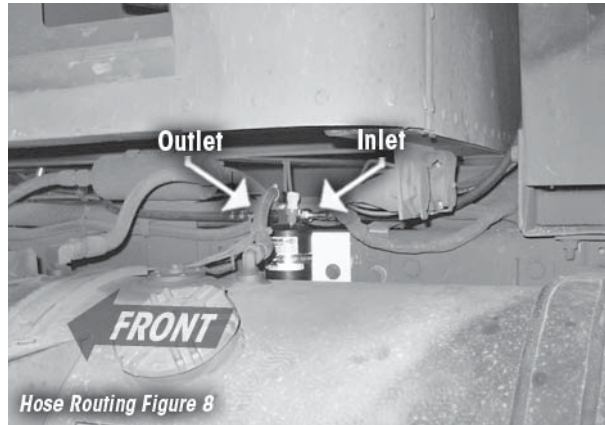

- 10.** Lubricate o-rings and install straight #6 male fitting on drier outlet and straight #6 female fitting on drier inlet (Hand tight only) Make certain receiver/drier is positioned correctly. Outlet must be facing forward and connects to hose from evaporator. Trim ends of hoses to length and crimp onto fittings. Tighten fittings. See figure 8

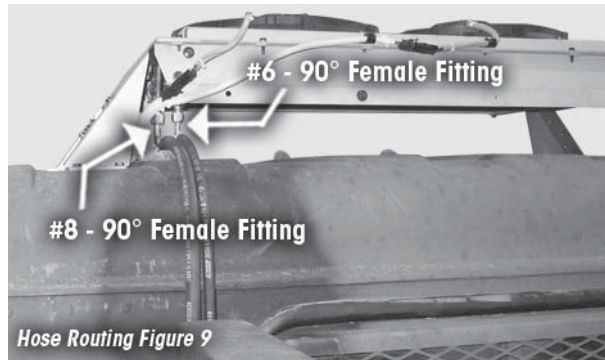

- 11.** Lubricate o-rings and install #6 female 90° and #8 female 90° fittings onto condenser unit. (Hand tight only) Trim hose ends to length and crimp onto fittings. Tighten fittings. See Figure 9

AEROQUIP® E-Z CLIP ASSEMBLY INSTRUCTIONS

Cut the Hose

Cut the hose to proper length with an appropriate cutting tool. Aeroquip's hand-held cutter (79R8920) has been specially designed for cutting all non-wire reinforced hose. Be sure the cut is made square to the hose length.



Slip Two Clips on the Hose

Slide two clips (be sure to use the correct size) onto the cut end of the hose. The orientation of the clips does not affect the performance of the connector. However, for ease of assembly, both clips should be oriented in the same direction. NOTE: If you don't slide the clips over the hose at this time, you will have to stretch the clips over the hose and fitting later. This may permanently damage the clip.



Oil the Nipple



Lubricate the nipple with a generous amount of the refrigeration or A/C system's compressor lubricating oil. This MUST be done to lower the force of nipple insertion.

Insert the Nipple into the Hose

Insert the nipple into the hose. To ensure that the nipple is fully inserted, check the gap between the cut end of the hose and the shoulder of the nipple. Care should be taken to avoid kinking or other damage to the hose during this step. NOTE: Be sure to wipe excess oil from the nipple and hose.



Snap on the Cage

Snap the cage into the groove on the nipple. The arms of the cage should extend over the hose-covered length of nipple. When the cage has been correctly installed in the cage groove, the cage will be able to rotate in the groove. This step MUST be performed to ensure that:

1. The clips will be located over the O-Rings on the nipple.
2. The connection will be compatible with the connection's pressure rating.



Position the Clips

Slide the clips over the cage arms and into the channels on each arm of the cage.



Close the Clips

Using the Connecting Tool (79R8920) to close the clips. The tool should be positioned squarely on the clip connection points and should remain square as pressure is applied and the clip is closed.

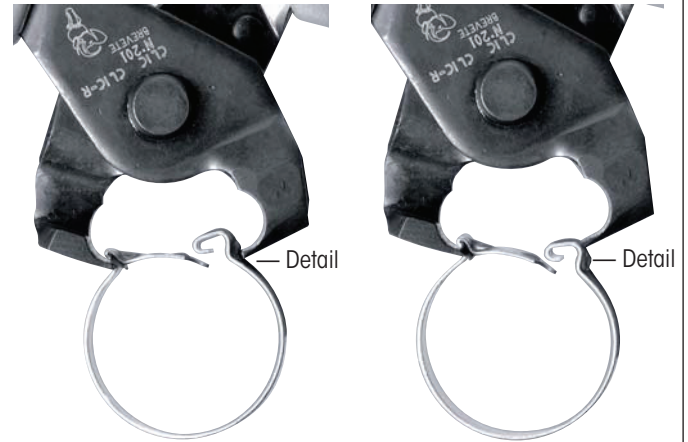

The nose of the plier should be firmly seated under the assembly bump and lock latch. If the pliers are not kept square as you close the clip, the clasp may have an offset. Use the pliers to correct the clasp alignment.



NOTE: E-Z Clip components should not be reused.

ELECTRICAL CONNECTIONS

1. Disconnect battery, (If not previously done during compressor mounting) to avoid electrical short circuits or accidental startup.

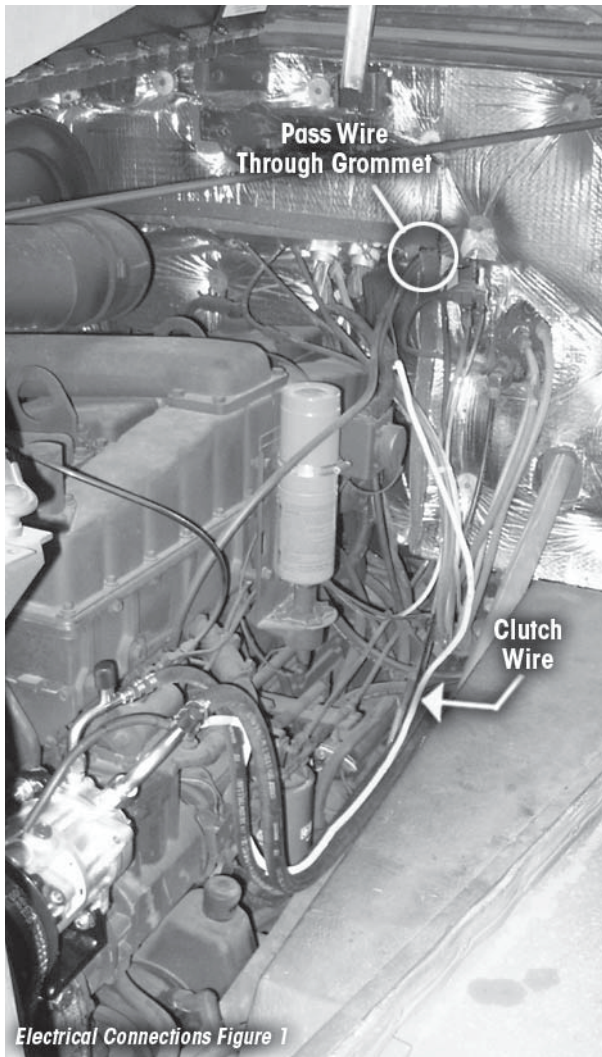

2. Locate clutch wire RD-2-4160-0 (Black wire with white stripe) in RD-2-4528-0 electrical kit. Connect clutch wire to compressor, route wire along refrigerant hoses towards firewall. Follow air lines to top of motor. Insert wire through firewall using tachometer grommet. See figure 1

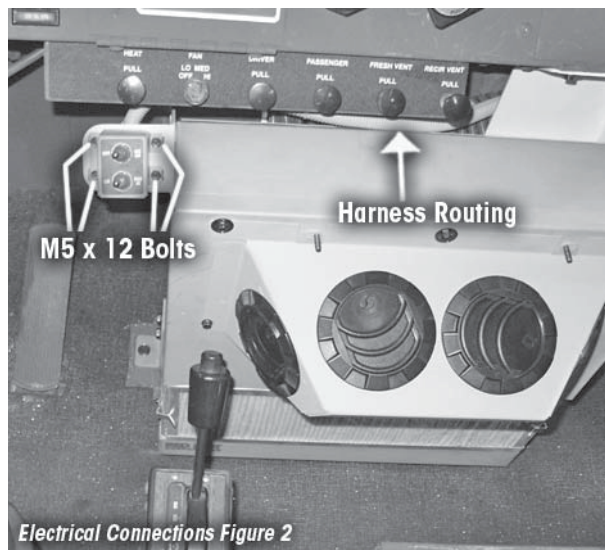

3. Locate control panel harness RD-2-4527-0 in electrical kit. From inside cab, attach air conditioner control panel to top evaporator mounting bracket on driver's side using four M5x12 bolts from kit D. Route harness around front of evaporator unit (Between evaporator unit and firewall) and connect to mating connector on evaporator unit harness. See Figure2

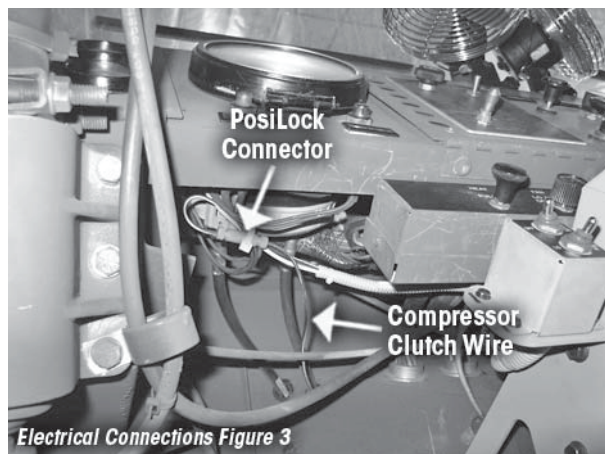

4. Connect previously run compressor clutch wire to black wire with white stripe from control panel extension using Posi-lock end splice connector. Secure with nylon tie wraps. See Figure 3

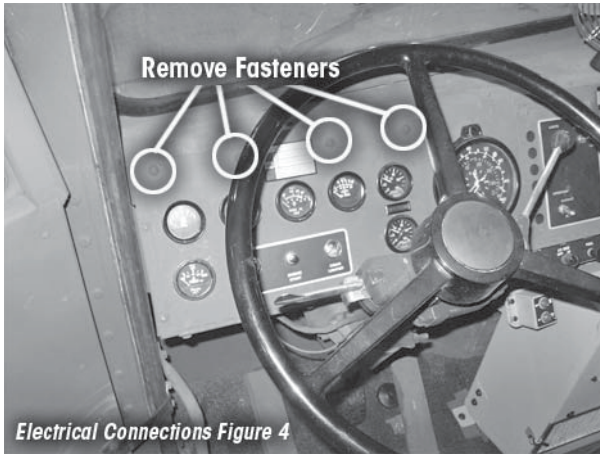

- 5.** Remove fasteners (and save if loose) attaching instrument cluster panel to dash board. Open cluster panel. See Figure 4

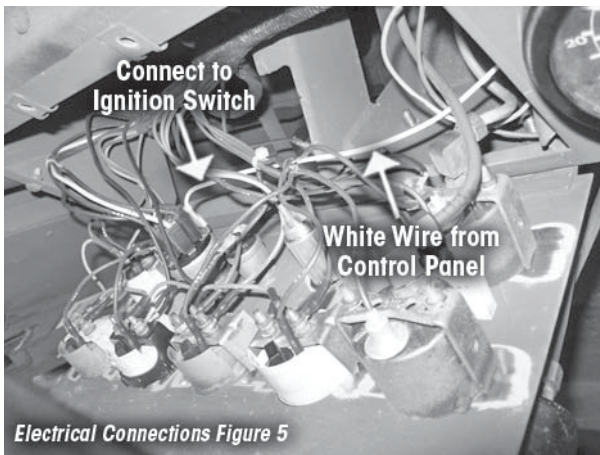

- 6.** Route white wire from control panel extension, under dash to the ignition switch on cluster panel. Attach connector

to open terminal on bottom of ignition switch. Secure wire with nylon tie wrap and reattach cluster panel to dash. See Figure 5

- 7.** Locate wire harness extension RD-4-5958-0 and 4 ft. jumper harness RD-4-4244-0 in electrical kit. Attach female end of 4ft. jumper harness to the male end of wire harness extension. See Figure 6, bottom

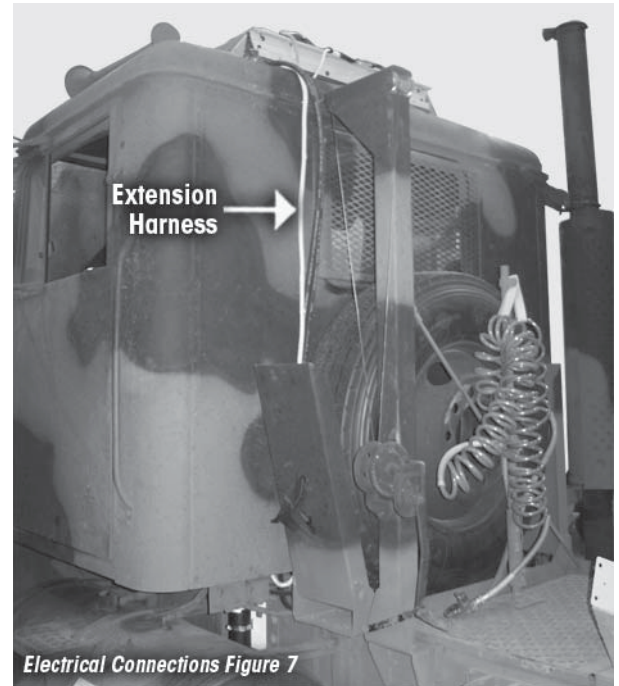

- 8.** Attach female end of completed harness to the male connector on the condenser unit harness. Route harness down rear of cab following refrigerant lines to receiver/drier. See figure 7

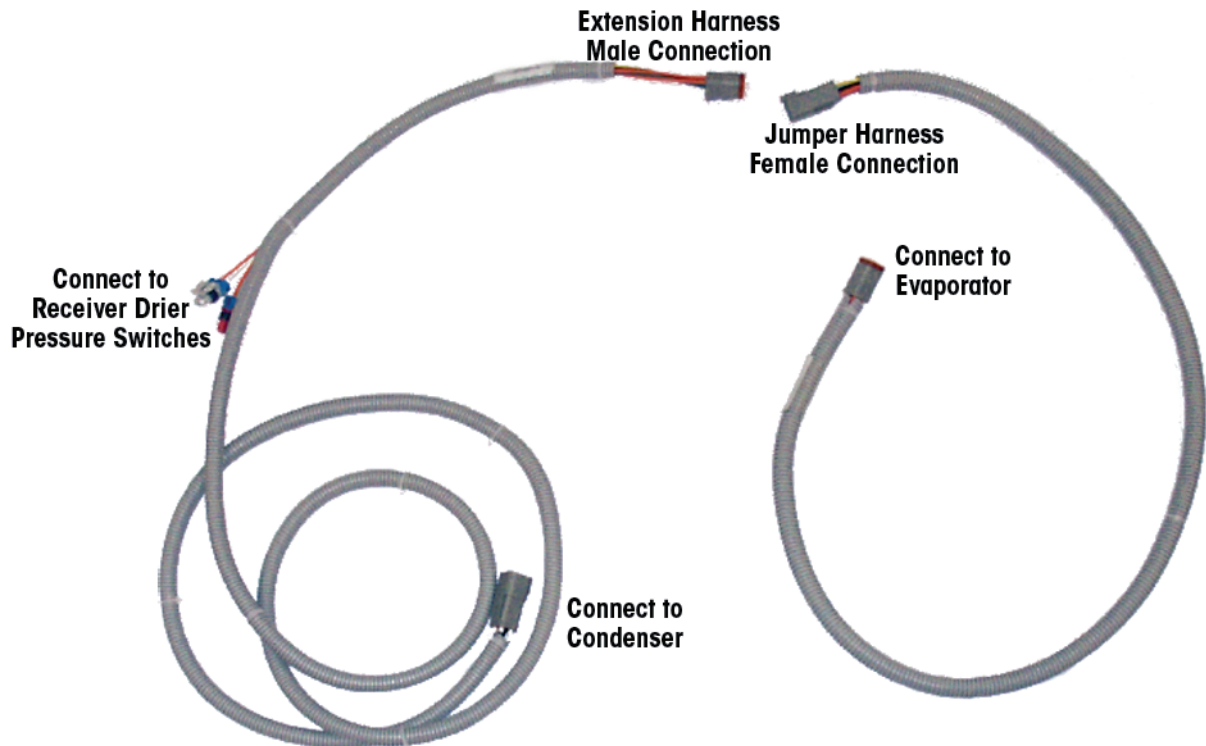

Electrical Connections Figure 6

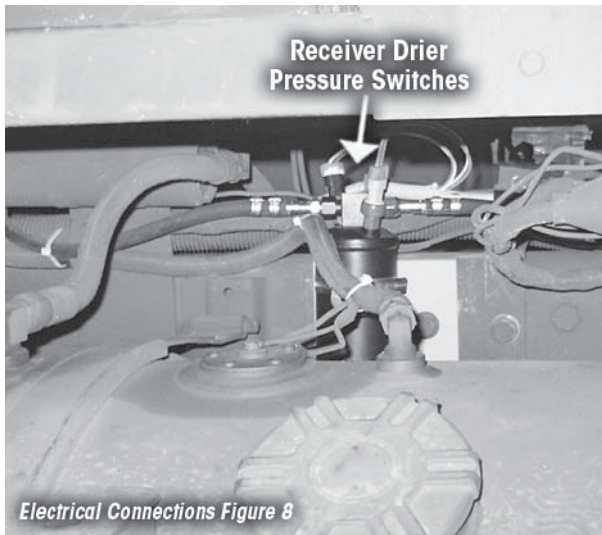

9. Connect harness to pressure switches on receiver/drier. **Pressure switch wire connectors are different, and must be connected to the correct switch. If it doesn't snap on with minimal pressure, try the other switch.** See Figure 8

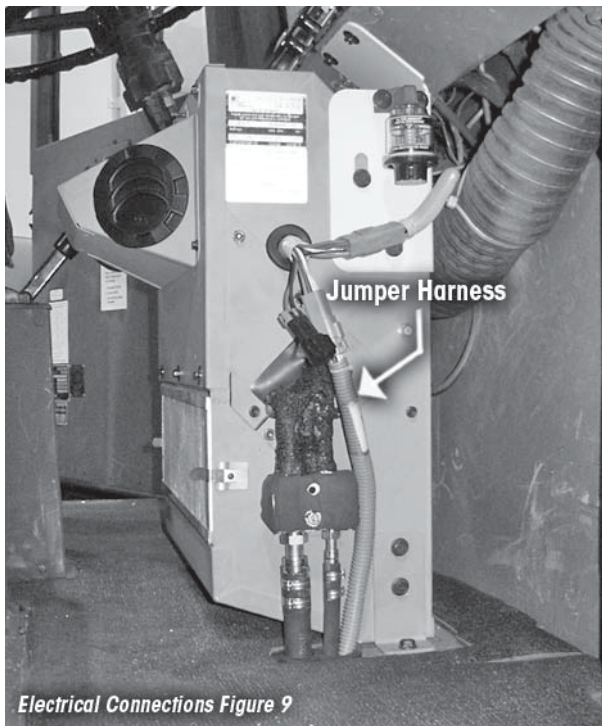

10. Route remaining leg of harness across the top of the transmission and up through floor using forward cone grommet. (HINT: Slide grommet up hose to allow grommet to stretch around connector, replace grommet) Attach connector to evaporator harness. Secure harness under vehicle using nylon tie wraps. See Figure 9

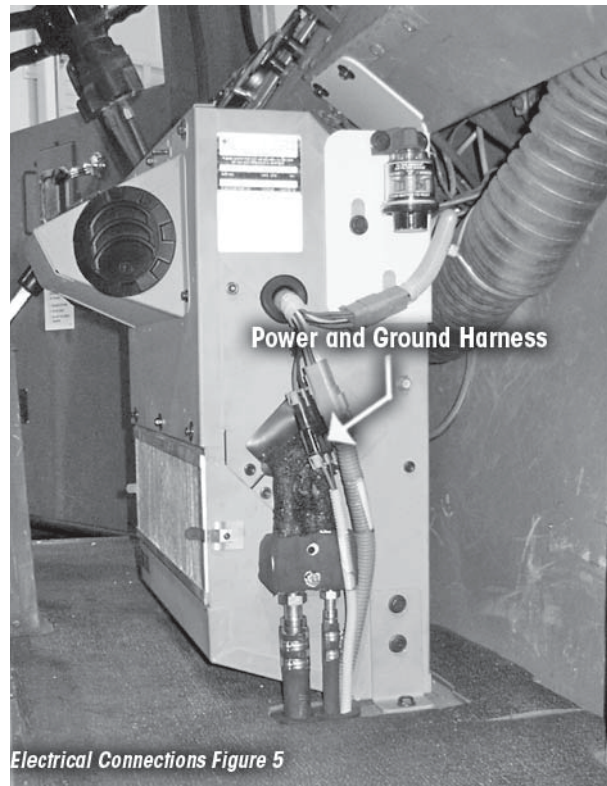

11. Connect power and ground harness to evaporator unit harness. Pass wires down through floor using forward cone grommet, and follow main power cable to battery box. See Figure 10

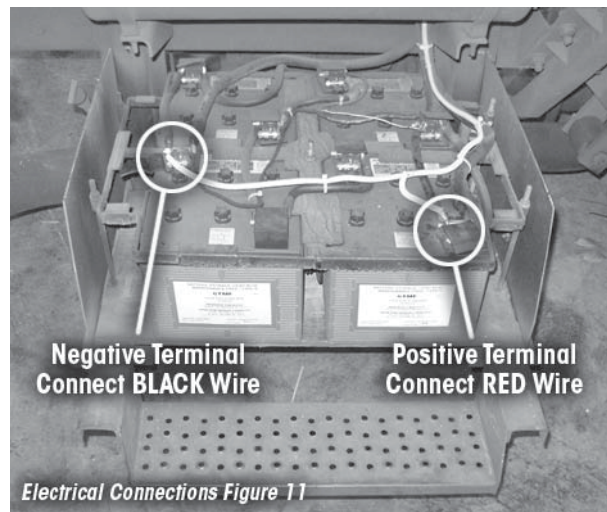

12. Attach Red wire to positive terminal of forward outboard battery, and black wire to negative terminal of rear outboard battery. (Check for 24volts DC as battery placement among vehicles may vary.) Secure harness along route using nylon tie wraps. See Figure 11

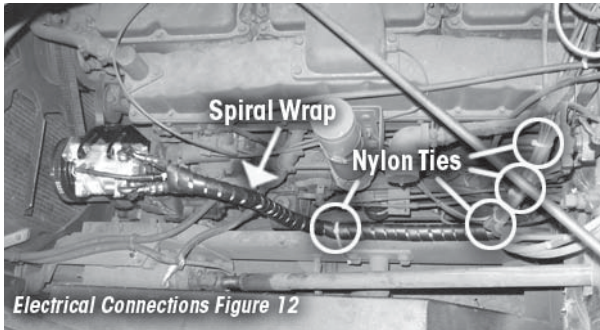

Electrical Connections Figure 12

- 13.** Locate spiral hose wrap. Cut a piece of spiral hose wrap approximately three feet in length and install around refrigerant lines and compressor harness in engine compartment. Secure with nylon tie wraps. Secure remaining compressor harness along route to firewall. See Figure 12

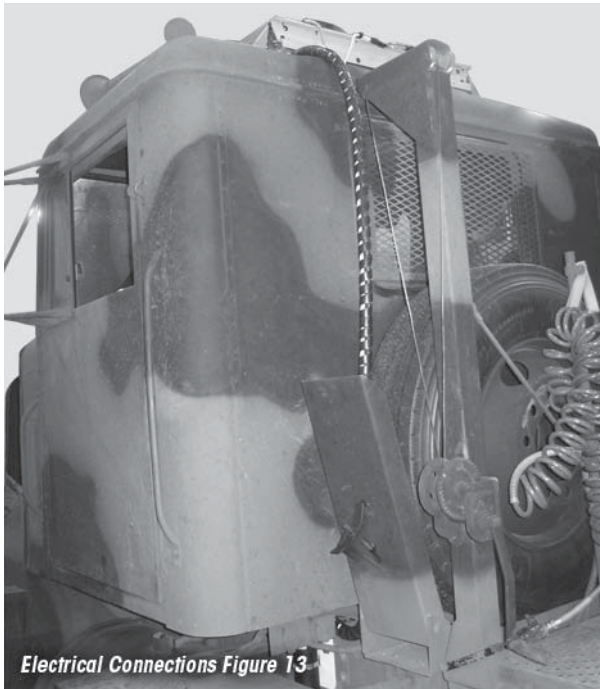

Electrical Connections Figure 13

- 14.** Starting at condenser, install spiral hose wrap around #6 and #8 refrigerant lines and wire harness. From condenser, continue down rear of cab to receiver/drier. See Figure 13

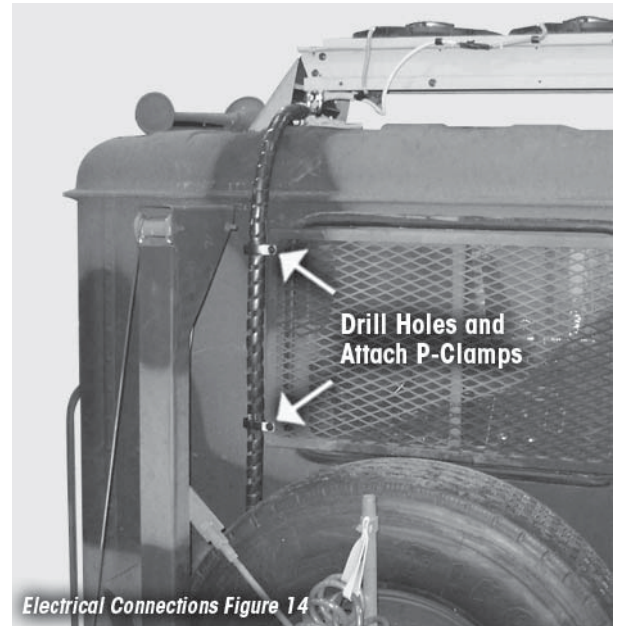

Electrical Connections Figure 14

- 15.** Using a 1/4" (.250") drill bit, drill two P-clamp mounting holes in rear window screen frame. (Driver's side) Attach P-clamps found in hose kit, to spiral wrapped hoses and mount to frame using two 1/4"x.875 bolts and two 1/4" nylon lock nuts also found in hose kit. See Figure 14



Electrical Connections Figure 15

- 16.** Position windshield washer bottle mounting bracket against firewall on passenger side of evaporator unit. Mark position of mounting holes on firewall. Remove mounting bracket and drill mounting holes using a 1/8" (.125") drill bit. Attach mounting bracket to firewall using three #8 Phillips head truss screws from kit D. See Figure 15



17. Insert windshield washer bottle and reconnect hoses. See figure 16

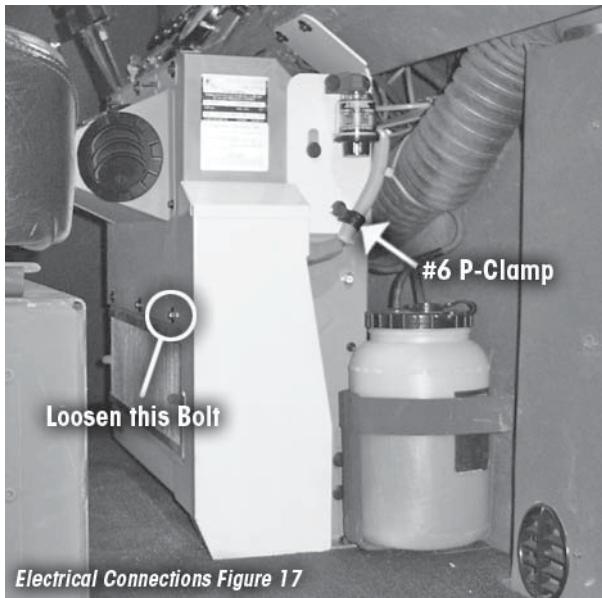

18. Locate plumbing cover RD-2-4488-0. Remove bottom bolt from evaporator top mount. (passenger side) Install #6 P-clamp from kit D on control panel harness. Loosen bolt

above right hand side of filter. Slide cover into position and tighten bolt above filter. Insert mount bolt through P-clamp, then through cover flange and into evaporator unit. Tighten bolt. See Figure 17



19. Reattach air line to air filter gauge and tighten. See Figure 18

20. Re-connect battery

CHARGING REFRIGERANT SYSTEM

Charging must be done by a certified A/C technician. Charge ports are on the compressor fittings.

Refrigerant	R-134a
Refrigerant charge	4.75 Lbs
Compressor oil	PAG SP15
Oil charge (supplied in compressor) (new system)	270 CC

THIS PAGE DELIBERATELY LEFT BLANK



RED DOT CORP. CHARGING

Aftermarket Office
P.O.Box 88790 Seattle, WA 98138
(206) 575-3840 fax (206) 574-6659

Charging must be done by
a certified A/C technician.
Charge ports are on the
compressor fittings.



Compressor Mounting M915 A0/A1 Truck with Cummins NTC400 Engine

RD-2-4530-0

INSTALLATION INSTRUCTIONS

TOOLS REQUIRED

- Ratchet
- 1/2" Ratchet or breaker bar
- 3/4" open end wrench
- 7/8" open end wrench
- 15/16" open end wrench or socket
- 3/4" socket
- 16mm socket
- 17mm open end wrench

CAUTION:

Always use appropriate safety equipment when operating power tools or working with pressurized systems.

Before starting installation review parts list included in kit to verify that all required parts needed for installation were received.

AIR CONDITIONER COMPRESSOR MOUNTING.

1. Disconnect battery to avoid electrical short circuits or accidental startup.

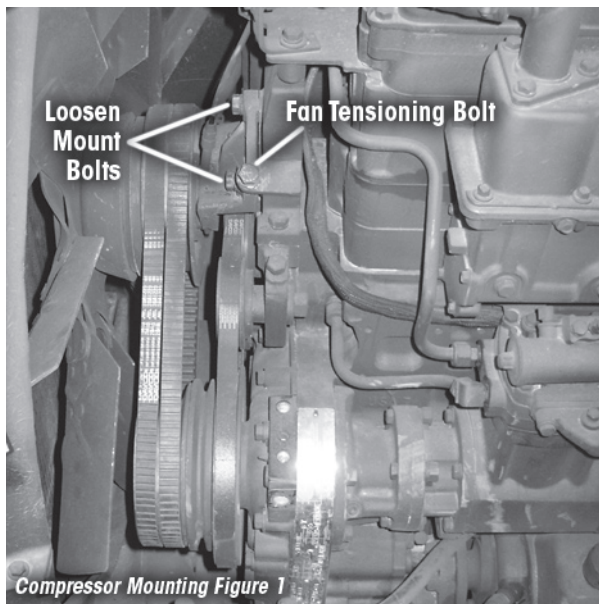

2. Using a 3/4" wrench, loosen the three mounting bolts holding the radiator fan assembly to the front of the engine. Loosen the jam nut on fan belt tensioning bolt, loosen tensioning bolt. See Figure 1

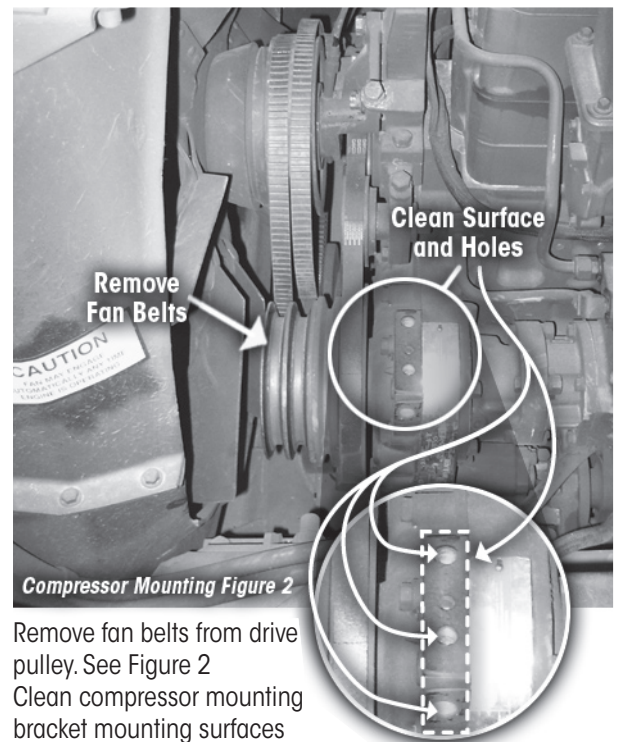

3. Remove fan belts from drive pulley. See Figure 2
4. Clean compressor mounting bracket mounting surfaces and mounting holes. See Figure 2



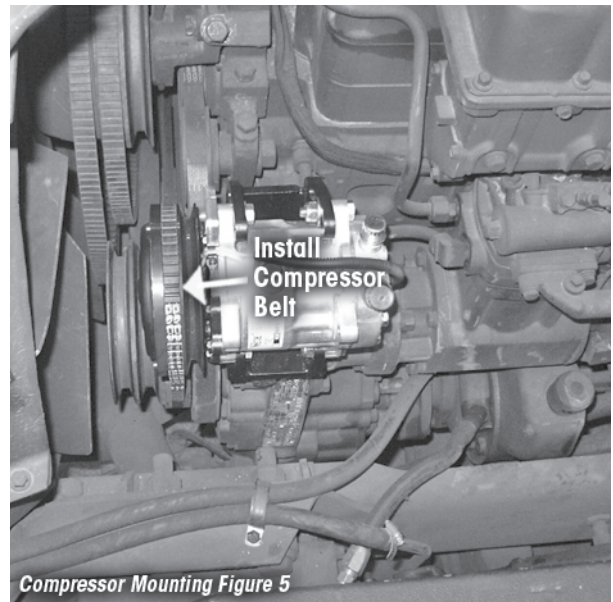
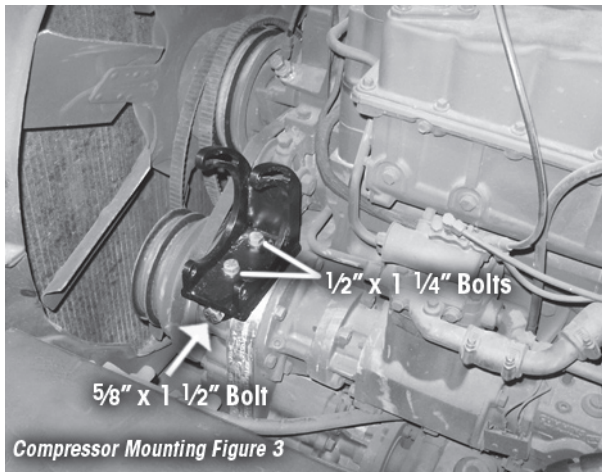

5. Install compressor mounting bracket using two 1/2" x 1 1/4" (1.250) bolts with lock washers and one 5/8" x 1 1/2" (1.50) bolt and lock washer. See Figure 3

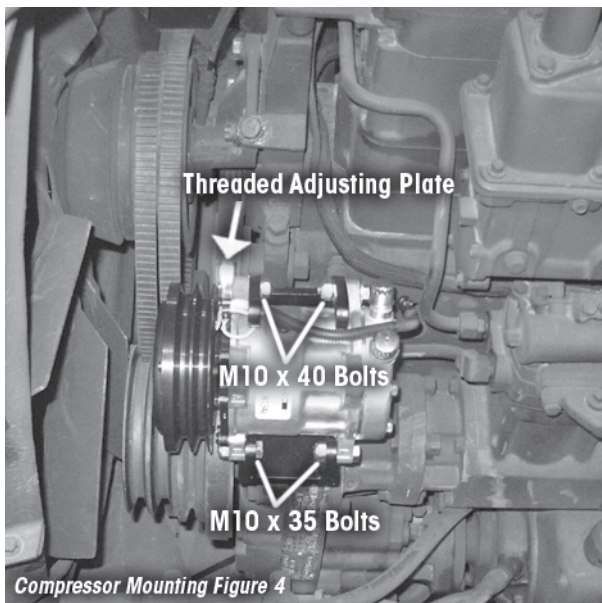

6. Install compressor to mounting bracket using two M10x35mm bolts with nylon lock nuts on bottom of bracket and two M10x40mm bolts with flat washers on top of bracket. Secure top rear bolt with nylon lock nut and top front bolt with threaded adjusting plate. (Do not tighten bolts at this time.) See Figure 4

7. Install belt on front groove of compressor pulley and rear groove on engine drive pulley. Tension belt by inserting a 1/2" drive breaker bar or ratchet into hole in adjusting plate on top of compressor. Rotate compressor outboard until proper belt tension is reached. Tighten all bolts. See Figure 5

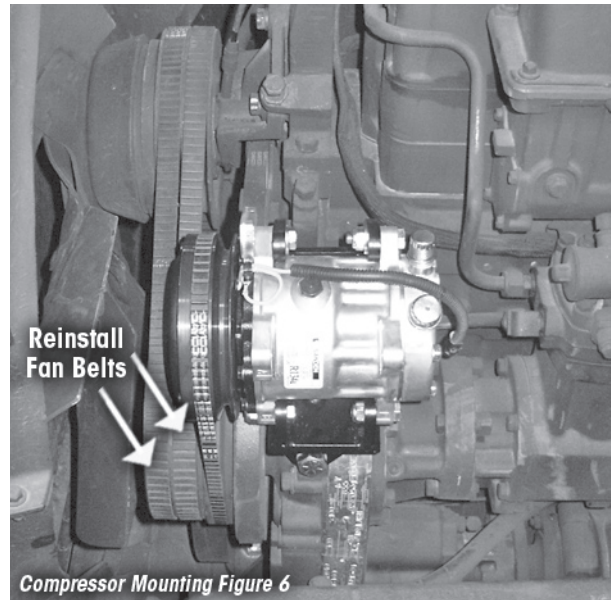

8. Reinstall fan belts, adjust belt tension, and tighten all bolts. See Figure 6
9. Re-connect battery.



RED DOT CORPORATION

Aftermarket Office

P.O.Box 88790 Seattle, WA 98138

(206) 575-3840 fax (206) 574-6659

REPAIR PARTS AND SPECIAL TOOLS LIST (RPSTL) INTRODUCTION

0028 00

SCOPE

This RPSTL lists and authorizes spares and repair parts for performance of Field Level Maintenance of the air conditioning system for the:

- Truck, Tractor, Line Haul, 6x4, M915P1
- Truck, Tractor, Line Haul, 6x4, M915A1P1
- Truck, Tractor, Light Equipment Transporter, 6x6 Winch, M916P1
- Truck Chassis, 8x6, For 20 Ton Dump Truck, M917P1
- Truck, Tractor, Medium Equipment Transporter, 8x6, with Winch, M920P1

It authorizes the requisitioning, issue, and disposition of spares and repair parts as indicated by the source, maintenance, and recoverability (SMR) codes.

GENERAL

In addition to the Introduction work package, this RPSTL is divided into the following work packages:

- a. **Repair Parts Lists Work Package.** Work package containing lists of spares and repair parts authorized by this RPSTL for use in the performance of maintenance. This work package also includes parts which must be removed for replacement of the authorized parts. Parts lists are composed of a single functional group, with the parts in each figure listed. Repair parts kits are listed separately in their own functional group. Items listed are shown on the associated illustrations.
- b. **Special Tools List Work Package.** There are no special tools for this Air Conditioning Kit.
- c. **Cross-Reference Indexes Work Package.** There are two cross-reference indexes in this RPSTL: National Stock Number Index and Part Number Index.

EXPLANATION OF COLUMNS IN THE REPAIR PARTS LISTS

- a. **Item No. (Column 1).** Indicates the number used to identify items called out in the illustration.
- b. **SMR Code (Column 2).** The SMR code containing supply/requisitioning information, maintenance level authorization criteria, and disposition instruction, as shown in the following breakout:

SOURCE CODE	MAINTENANCE CODE		RECOVERABILITY CODE
XXxxx	xxXXx		xxxxX
1st two positions	3rd position	4th position	5th position
How you get an item.	Who can install, replace or use the item.	Who can do complete repair* on the item.	Who determines disposition action on an unserviceable item.

* *Complete Repair:* Maintenance capacity, capability, and authority to perform all corrective maintenance tasks of the "Repair" function in a use/user environment in order to restore serviceability to a failed item.

EXPLANATION OF COLUMNS IN THE REPAIR PARTS LISTS - CONTINUED

- (1) **Source Code.** The source code tells you how to get an item needed for maintenance, repair, or overhaul of an end item/equipment. Explanations of source codes follow:

<u>Code</u>	<u>Application/Explanation</u>
PA PB PC PD PE PF PG	Stocked items; use the applicable NSN to request/requisition items with these source codes. They are authorized to the maintenance category indicated by the code entered in the third position of the SMR code. <i>Items coded PC are subject to deterioration.</i>
KD KF KB	Items with these codes are not to be requested/requisitioned individually. They are part of a kit which is authorized to the maintenance level indicated in the third position of the SMR code. The complete kit must be requisitioned and applied.
MO - Made at Unit/ AVUM level MF - Made at DS/AVIM Level MH - Made at GS Level ML - Made at SRA MD - Made at Depot	Items with these codes are not to be requested/requisitioned individually. They must be made from bulk materiel which is identified by the part number in the DESCRIPTION AND USABLE ON CODE (UOC) column and listed in the bulk materiel group work package of the RPSTL. If the item is authorized to you by the third position of the SMR code, but the source code indicates it is made at a higher level, order the item from the higher level of maintenance.
AO-Assembled by Unit/ AVUM level AF-Assembled by DS/ AVIM level AH-Assembled by GS level AL-Assembled by SRA AD-Assembled by Depot	Items with these codes are not to be requested/requisitioned individually. The parts that make up the assembled item must be requisitioned or fabricated and assembled at the level of maintenance indicated by the source code. If the third position of the SMR code authorizes you to replace the item, but the source code indicates the item is assembled at a higher level, order the item from the higher level of maintenance.
XA	DO NOT requisition an "XA" coded item. Order the next higher assembly. (Refer to NOTE below).
XB	If an item is not available from salvage, order it using the CAGEC and P/N.
XC	Installation drawings, diagrams, instruction sheets, field service drawings; identified by manufacturer's P/N.
XD	Item is not stocked. Order an XD-coded item through normal supply channels using the CAGEC and P/N given, if no NSN is available.

NOTE

Cannibalization of controlled exchange, when authorized, may be used as a source of supply for items with the above source codes, except for those source coded "XA" or those aircraft support items restricted by requirements of AR 750-1.

EXPLANATION OF COLUMNS IN THE REPAIR PARTS LISTS - CONTINUED

(2) **Maintenance Code.** Maintenance codes tell you the level(s) of maintenance authorized to use and repair support items. The maintenance codes are entered in the third and fourth positions of the SMR code as follows:

(a) **Third Position.** The maintenance code entered in the third position tells you the lowest maintenance level authorized to remove, replace, and use an item. The maintenance code entered in the third position will indicate authorization to one of the following levels of maintenance:

<u>Code</u>	<u>Application/Explanation</u>
C	Crew or Operator maintenance done within Field/AVUM maintenance.
O	Unit Level/AVUM maintenance can remove, replace, and use the item.
F	Direct Support/AVIM maintenance can remove, replace, and use the item.
H	General Support maintenance can remove, replace, and use the item.
L	Specialized Repair Activity (SRA) can remove, replace, and use the item.
D	Depot Maintenance can remove, replace, and use the item.

(b) **Fourth Position.** The maintenance code entered in the fourth position tells you whether or not the item is to be repaired and identifies the lowest maintenance level with the capability to do complete repair (perform all authorized repair functions).

NOTE

Some limited repair may be done on the item at a lower level of maintenance, if authorized by the Maintenance Allocation Chart (MAC) and SMR codes.

<u>Code</u>	<u>Application/Explanation</u>
O	Unit/AVUM is the lowest level that can do complete repair of the item.
F	Direct Support/AVIM is the lowest level that can do complete repair of the item.
H	General Support is the lowest level that can do complete repair of the item.
L	Specialized Repair Activity (SRA) is the lowest level that can do complete repair of the item.
D	Depot is the lowest level that can do complete repair of the item.
Z	Nonrepairable. No repair is authorized.
B	No repair is authorized. No parts or special tools are authorized for the maintenance of a "B"-coded item. However, the item may be reconditioned by adjusting, lubricating, etc., at the user level.

EXPLANATION OF COLUMNS IN THE REPAIR PARTS LISTS - CONTINUED

- (3) **Recoverability Code.** Recoverability codes are assigned to items to indicate the disposition action on unserviceable items. The recoverability code is entered in the fifth position of the SMR code as follows:

<u>Code</u>	<u>Application/Explanation</u>
Z	Nonrepairable item. When unserviceable, condemn and dispose of the item at the level of maintenance shown in the third position of the SMR code.
O	Reparable item. When uneconomically repairable, condemn and dispose of the item at the Unit level maintenance.
F	Reparable item. When uneconomically repairable, condemn and dispose of the item at Direct Support level.
H	Reparable item. When uneconomically repairable, condemn and dispose of the item at General Support level.
D	Reparable item. When beyond lower level repair capability, return to depot. Condemnation and disposal of item are not authorized below depot level.
L	Reparable item. Condemnation and disposal of item not authorized below Specialized Repair Activity (SRA).
A	Item requires special handling or condemnation procedures because of specific reasons (e.g., precious metal content, high dollar value, critical material, or hazardous material). Refer to appropriate manuals/directives for specific instructions.

- c. **NSN - (Column 3).** The NSN for the item is listed in this column.
- d. **CAGEC (Column 4).** The Commercial and Government Entity Code (CAGEC) is a five-digit code which is used to identify the manufacturer, distributor, or Government agency/activity that supplies the item.
- e. **PART NUMBER (Column 5).** Indicates the primary number used by the manufacturer (individual, company, firm, corporation, or Government activity), which controls the design and characteristics of the item by means of its engineering drawings, specifications, standards, and inspection requirements to identify an item or range of items.

NOTE

When you use an NSN to requisition an item, the item you receive may have a different part number from the part ordered.

- f. **DESCRIPTION AND USABLE ON CODE (UOC) (Column 6).** This column includes the following information:
 - (1) The Federal item name and, when required, a minimum description to identify the item.
 - (2) P/Ns of bulk materials are referenced in this column in the line entry to be manufactured or fabricated.
 - (3) Hardness Critical Item (HCI). A support item that provides the equipment with special protection from electromagnetic pulse (EMP) damage during a nuclear attack.
 - (4) The statement END OF FIGURE appears just below the last item description in column (6) for a given figure in both the repair parts list and special tools list work packages.

EXPLANATION OF COLUMNS IN THE REPAIR PARTS LISTS - CONTINUED

- g. **QTY (Column 7).** The QTY (quantity per figure) column indicates the quantity of the item used in the breakout shown on the illustration/figure, which is prepared for a functional group, subfunctional group, group or an assembly. A “V” appearing in this column in lieu of a quantity indicates that the quantity is variable and the quantity may vary from application to application.

EXPLANATION OF CROSS-REFERENCE INDEXES WORK PACKAGE FORMAT AND COLUMNS

- a. **National Stock Number (NSN) Index Work Package.**
 - (1) **STOCK NUMBER Column.** This column lists the NSN by National Item Identification Number (NIIN) sequence. The NIIN consists of the last nine digits of the NSN (i.e., NSN 5305-01-674-1467). When using this column to locate an item, ignore the first four digits of the NSN. However, the complete NSN should be used when ordering items by stock number.
 - (2) **FIG. Column.** This column lists the number of the figure where the item is identified/located. The figures are in numerical order in WP 0029 00.
 - (3) **ITEM Column.** The item number identifies the item associated with the figure listed in the adjacent FIG. column. This item is also identified by the NSN listed on the same line.
- b. **Part Number (P/N) Index Work Package.** Part numbers in this index are listed in ascending alphanumeric sequence (i.e., vertical arrangement of letter and number combination which places the first letter or digit of each group in order A through Z, followed by the numbers 0 through 9 and each following letter or digit in like order).
 - (1) **PART NUMBER Column.** Indicates the P/N assigned to the item.
 - (2) **FIG. Column.** This column lists the number of the figure where the item is identified/located in the repair parts list and special tools list work packages.
 - (3) **ITEM Column.** The item number is the number assigned to the item as it appears in the figure referenced in the adjacent figure number column.

SPECIAL INFORMATION

- a. **Usable On Code (UOC).** The UOC appears in the lower left corner of the DESCRIPTION column heading. Usable on codes are shown as “UOC:” in the Description Column (justified left) on the first line under the applicable item/nomenclature. Uncoded items are applicable to all models. Identification of the UOC’s used in the RPSTL are:

<u>Code</u>	<u>Used On</u>
5K1	M915P1, M915A1P1, M916P1, M917P1, and M920P1 Air Conditioning Kit

- b. **Associated Publications.** The publication(s) listed below pertain to the M915 Type Line-Haul Truck and its components:

Publication	Short Title
TM 9-2320-273- Series	Series of Manuals for the M915, M916, M917, M918, M919, and M920 Line-Haul Truck
TM 9-2320-283- Series	Series of Manuals for the M915A1 Line-Haul Truck

HOW TO LOCATE REPAIR PARTS

a. **When National Stock Number is Known.**

- (1) **First.** If you have the NSN, look in the STOCK NUMBER column of the NSN index work package. The NSN is arranged in NIIN sequence. Note the figure and item number next to the NSN.
- (2) **Second.** Turn to the figure and locate the item number. Verify that the item is the one you are looking for.

b. **When Part Number is Known.**

- (1) **First.** If you have the P/N and not the NSN, look in the PART NUMBER column of the P/N index work package. Identify the figure and item number.
- (2) **Second.** Look up the item on the figure in the applicable repair parts list work package.

ABBREVIATIONS

For standard abbreviations see ASME Y14.38-1999, *Abbreviations and Acronyms*.

<u>Abbreviations</u>	<u>Explanation</u>
NIIN	National Item Identification Number (consists of the last 9 digits of the NSN)
RPSTL	Repair Parts and Special Tools Lists
SMR	Source, Maintenance, and Recoverability Code
TMDE	Test, Measurement, and Diagnostic Equipment
THK	Thickness

END OF WORK PACKAGE

REPAIR PARTS AND SPECIAL TOOLS LIST (RPSTL)

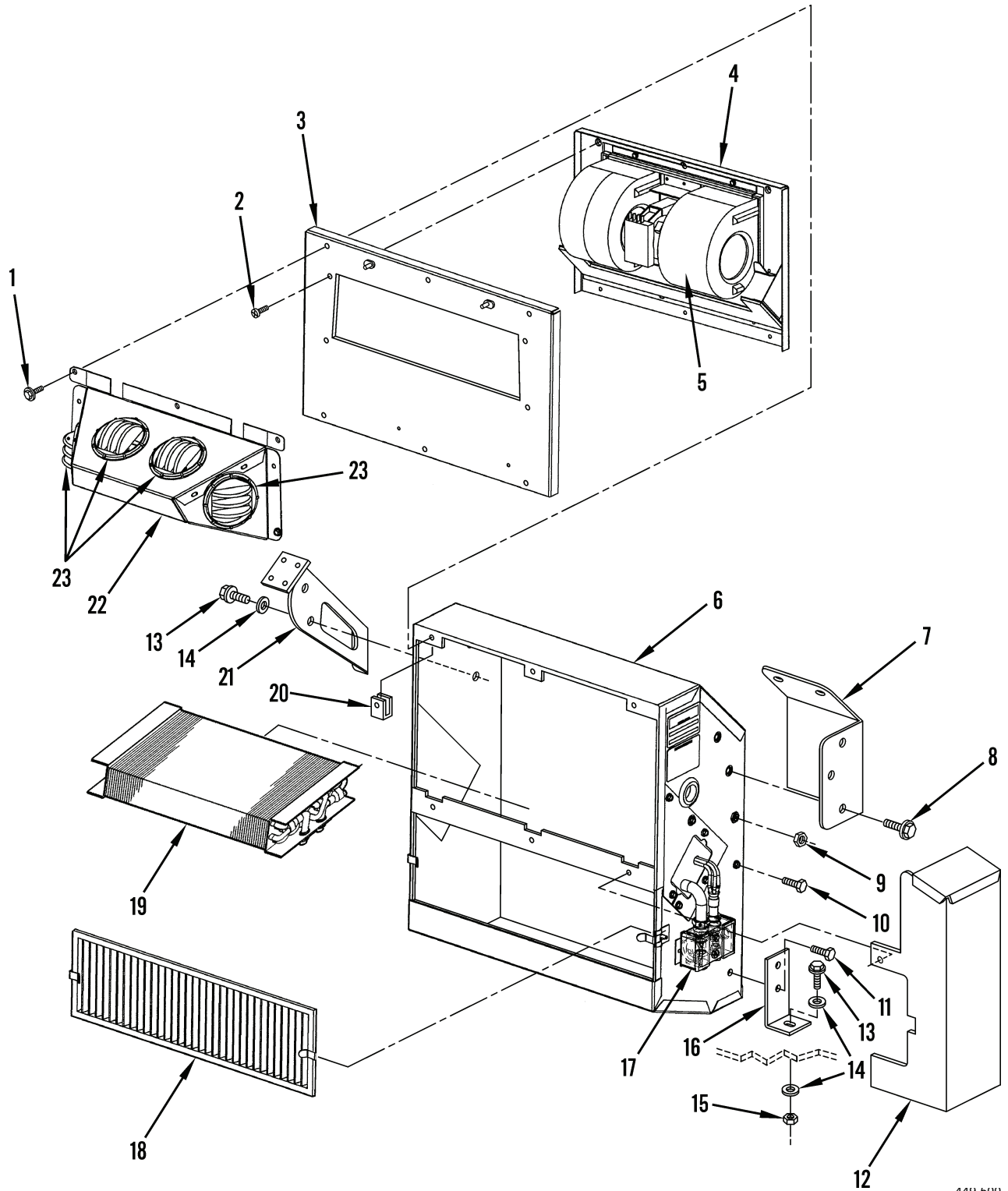

449-500

Figure 1. A/C Evaporator Assembly and Mounting Hardware (Sheet 1 of 2)

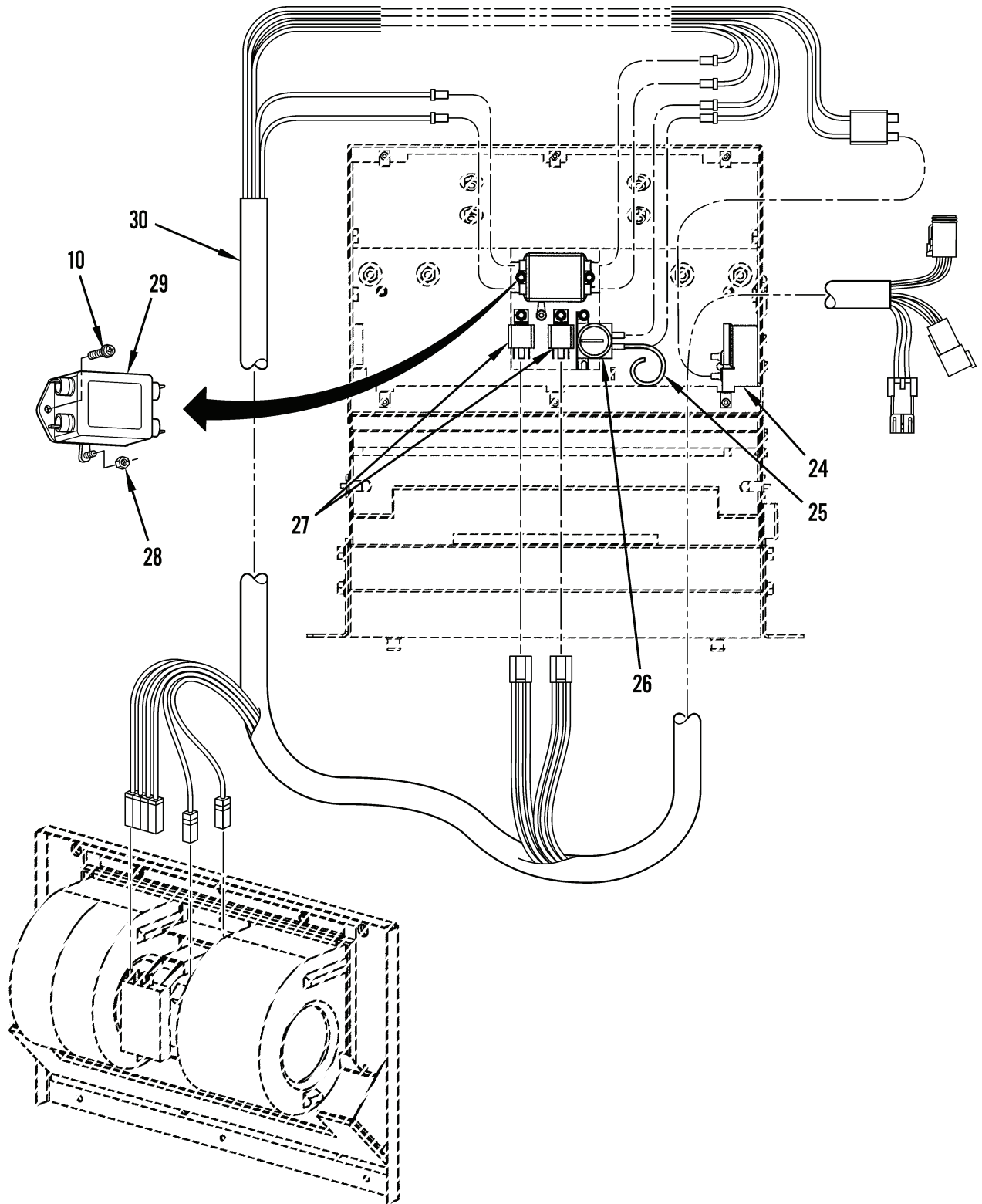

Figure 1. A/C Evaporator Assembly and Mounting Hardware (Sheet 2 of 2)

(1) ITEM NO	(2) SMR CODE	(3) NSN	(4) CAGEC	(5) PART NUMBER	(6) DESCRIPTION AND USABLE ON CODES (UOC)	(7) QTY
					GROUP 33 SPECIAL PURPOSE KITS GROUP 3307 SPECIAL PURPOSE KITS	
					FIG. 1 A/C EVAPORATOR ASSEMBLY AND MOUNTING HARDWARE	
1	PAOZZ	5305015231947	62534	RD-5-10825-1-16M	SCREW,CAP,HEXAGON H M5 X 0.8 & CON WASHER.....	1
2	PAOZZ	5305015298067	62534	RD-5-5630-1-16	SCREW,MACHINE M5 X 0.8 -8G HEX WSH HD.....	1
3	PAOZZ	5340015231985	62534	RD-2-4126-0P	COVER,ACCESS.....	1
4	PAOZZ		62534	RD-2-4150-0	BRACKET,BLOWER MOUN.....	1
5	PAOZZ		62534	RD-5-11436-0	MOTOR,BLOWER.....	1
6	PAOZZ	5340015238425	62534	RD-2-4116-0	COVER,ACCESS.....	1
7	PAOZZ		62534	RD-2-4498-0	BRACKET,EVAPORATOR.....	1
8	PAOZZ	5305000687837	80204	B1821BH025C063N	SCREW,CAP,HEXAGON H 1/4 X .875.....	1
9	PAOZZ	5310015281391	62534	RD-5-4133-0	NUT,PLAIN,HEXAGON 7/16-28 UNEF-28..	1
10	PAOZZ	5305015242260	62534	RD-5-7213-1-.375	SCREW,CAP,HEXAGON H 10 X 16 B HX WR HD.....	8
11	PAOZZ	5305015232459	62534	RD-5-5351-1-25M	SCREW,CAP,HEXAGON H M8 X 1.25 HX WSHR HD.....	1
12	PAOZZ	5340015591990	62534	RD-2-4512-0	COVER ASSEMBLY,PLUM.....	1
13	PAOZZ	5306002264829	80204	B1821BH031C125N	BOLT,MACHINE 5/16 X 1.25.....	1
14	PAOZZ	5310000814219	96906	MS27183-12	WASHER,FLAT.....	1
15	PAOZZ	5310009843807	81349	M45913/1-5FG5C	NUT,SELF-LOCKING,HE.....	1
16	PAOZZ	5340015593743	62534	RD-2-4597-0	BRACKET EVAP LOWER ANGLE.....	1
17	PAOZZ		62534	RD-5-11438-0	VALVE,EXPANSION 2 TON.....	1
18	PAOZZ	4130015217486	62534	RD-2-4132-OP	FILTER ELEMENT,AIR PLEATED POLYPROPYLENE.....	1
19	PAOZZ	4130015216442	62534	RD-2-4129-0P	EVAPORATOR COIL,REF.....	1
20	PAOZZ	5310015231552	62534	RD-5-5381-0	NUT,CLIP-ON M5-8.....	1
21	PAOZZ		62534	RD-2-4484-0	BRACKET,MOUNTING UPPER LEFT.....	1
22	PAOZZ	5340015593666	62534	RD-2-4495-0	PLENUM ASSEMBLY.....	1
23	PAOZZ	2540015590356	62534	RD-5-10236-0	LOUVER.....	1
24	PAOZZ	5925015589577	62534	RD-5-11437-0	CIRCUIT BREAKER 30 AMP.....	1
25	PAOZZ	4710015230548	62534	RD-5-3816-16P	TUBE,BENT,METALLIC 1/8" ID.....	1
26	PAOZZ	6685015174892	62534	RD-5-11440-0P	THERMOSTAT,FLOW CON SIDE & BOTTOM MOUNTED.....	1
27	PAOZZ	5945011706666	10988	L118429	RELAY,ELECTROMAGNET 24 V.....	1
28	PAOZZ	5310015233713	62534	RD-5-6831-0M	NUT,PLAIN,ROUND M5 X .8.....	1
29	PAOZZ	2540015239277	62534	RD-5-11444-0P	DIFFUSER,AIR,VEHICU.....	1
30	PAOZZ	6150015214634	62534	RD-2-4153-0P	WIRING HARNESS.....	1

END OF FIGURE

1
2 THRU 16

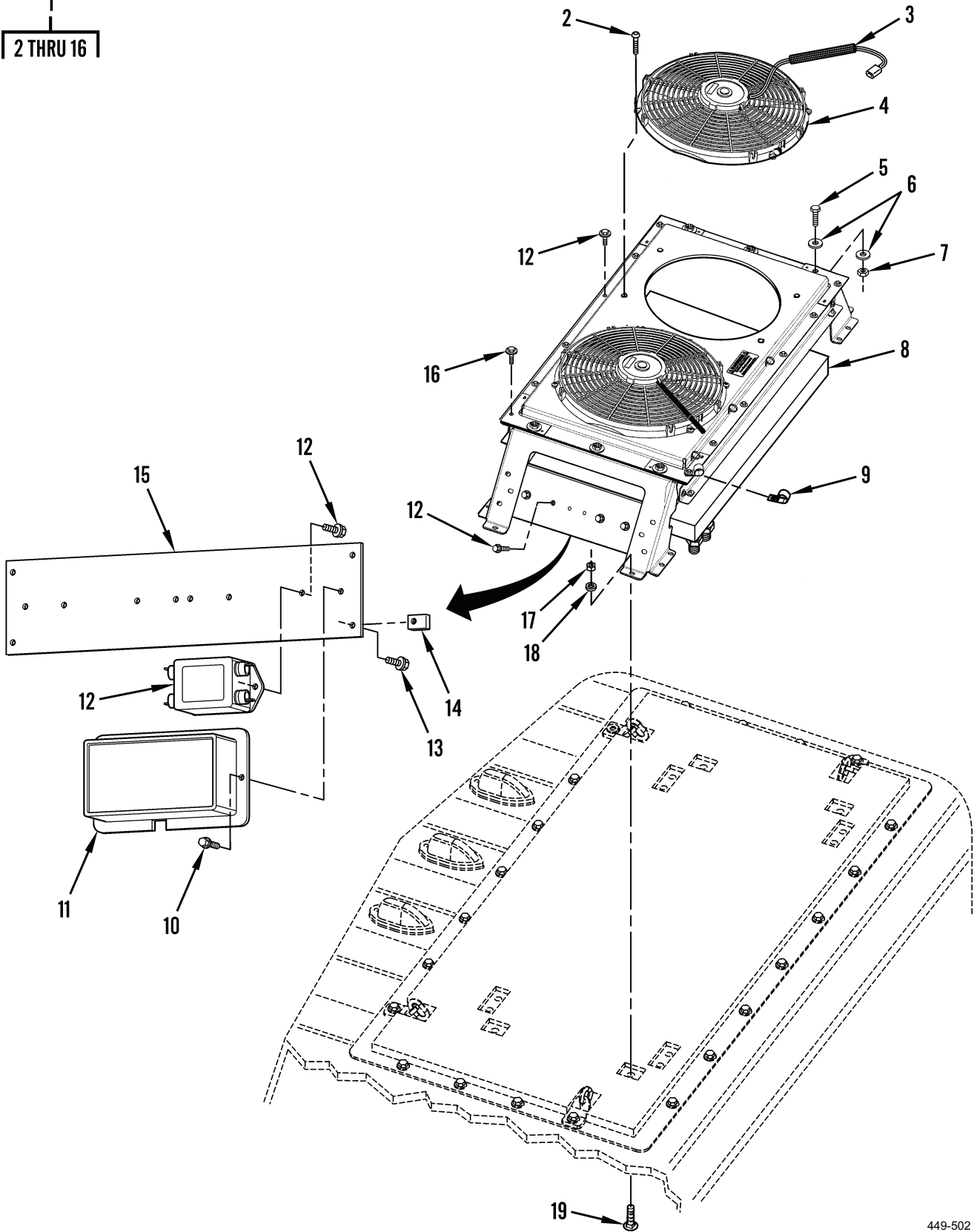

Figure 2. A/C Condenser Assembly

(1) ITEM NO	(2) SMR CODE	(3) NSN	(4) CAGEC	(5) PART NUMBER	(6) DESCRIPTION AND USABLE ON CODES (UOC)	(7) QTY
GROUP 3307 SPECIAL PURPOSE KITS						
FIG. 2 A/C CONDENSER ASSEMBLY						
1	PAOZZ	4130015590355	62534	RD-4-6060-0P	CONDENSER ASSEMBLY.....	1
2	PAOZZ	5305015231683	62534	RD-5-8980-1-20	.SCREW,MACHINE MS X 1.0 TORX HD....	1
3	PAOZZ	5970015233109	62534	RD-5-7357-8.5P	.INSULATION SLEEVING.....	1
4	PAOZZ	4140015216422	62534	RD-5-8785-3P	.FAN,CIRCULATING.....	1
5	PAOZZ	5306015231006	62534	RD-5-11390-0-1.5 00M	.BOLT,MACHINE 24 VOLT.....	1
6	PAOZZ	5310015233710	62534	RD-5-11388-0M	.WASHER,FLAT 1/2-13.....	1
7	PAOZA	5310015232651	62534	RD-5-11392-0	.NUT,SELF-LOCKING,HE 1/2 " 1.375 OD	1
8	XAOZZ		62534	RD-5-5857-0	.COIL,CONDENSER 1/2-13.....	1
9	PAOZZ	5340015545536	62534	RD-5-4665-0M	.CLAMP,LOOP.....	1
10	PAOZZ	5305015591991	62534	RD-5-1212-1-.375	.SCREW,HEX HD 0.75 ID.....	1
11	PAOZZ	5340015232408	62534	RD-4-5886-0	.COVER,ACCESS 1/4-14.....	1
12	PAOZZ	5305015179283	62534	RD-5-8222-1-16	.SCREW,ASSEMBLED WAS.....	1
13	PAOZZ	5915015216706	62534	RD-5-11445-0P	.FILTER ASSEMBLY,ELE W/WASHER.....	1
14	PAOZZ	5310015179443	62534	RD-5-5679-0M	.NUT,CLIP-ON.....	1
15	PAOZZ	5340015251931	62534	RD-4-5968-0P	.PLATE,MOUNTING.....	1
16	PAOZZ	5305015298296	62534	RD-5-8222-1-22M	.SCREW,CAP,HEXAGON H.....	1
17	PAOZA	5310015258946	62534	RD-5-10818-0M	.NUT,SELF-LOCKING,HE W/WASHER.....	1
18	PAOZZ	5310000814219	96906	MS27183-12	.WASHER,FLAT 5/16".....	1
19	PAOZZ	5305015232459	62534	RD-5-5351-1-25M	.SCREW,CAP,HEXAGON H M8 X 1.25 X 25MM.....	1

END OF FIGURE

14
15 THRU 21

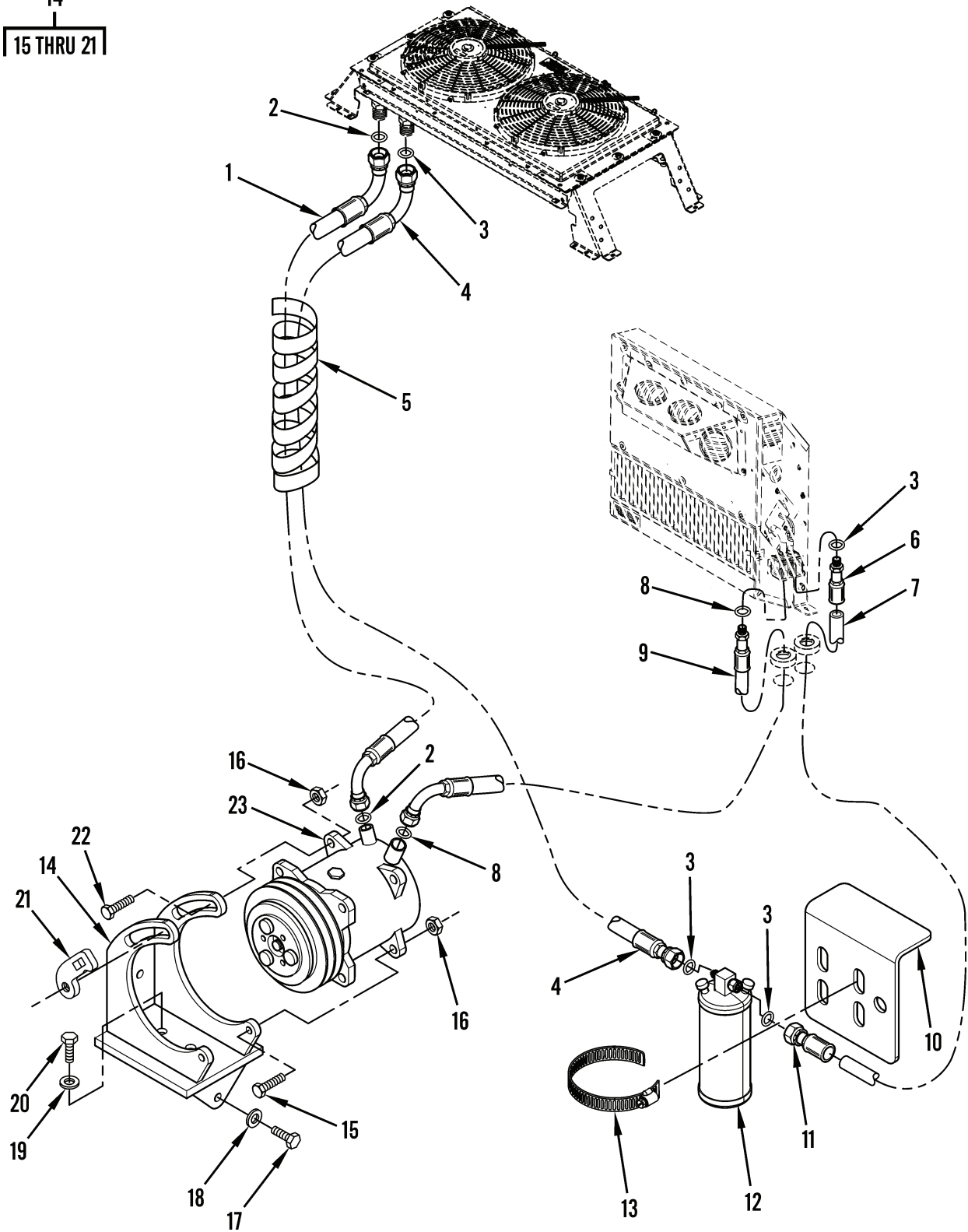

Figure 3. A/C Hoses, Compressor, and Receiver/Dryer

(1) ITEM NO	(2) SMR CODE	(3) NSN	(4) CAGEC	(5) PART NUMBER	(6) DESCRIPTION AND USABLE ON CODES (UOC)	(7) QTY
-------------------	--------------------	------------	--------------	-----------------------	--	------------

GROUP 3307 SPECIAL PURPOSE KITS

FIG. 3 A/C HOSES, COMPRESSOR, AND RECEIVER/DRYER

1	PAOZZ	4720015589863	62534	RD-5-10505-218	HOSE # 8.....	1
2	PAOZZ	5331015330282	62534	RD-5-11016-0	O-RING # 8.....	1
3	PAOZZ	5331015571933	62534	RD-5-11015-0	O-RING # 6.....	1
4	PAOZZ	4720015593740	62534	RD-5-10504-182	HOSE # 6.....	1
5	PAOZZ	9330015314309	62534	RD-5-7747-96P	TUBING, PLASTIC, SPIR.....	1
6	PAOZZ	4730015593177	62534	RD-5-10531-0P	FITTING, STRAIGHT, MA #6, STRAIGHT MALE.....	1
7	MFOZZ		62534	RD-5-10504-DRY	HOSE MAKE FROM BULK PN RD-5-10504-600M, CUT TO LENGTH.....	1
8	PAOZZ	5331015330281	62534	RD-5-11017-0	O-RING # 10.....	1
9	PAOZZ	4720015589866	62534	RD-5-10507-136	HOSE # 12.....	1
10	PAOZZ		62534	RD-4-6096-0	BRACKET, RECEIVER DR.....	1
11	PAOZZ	4730015239474	62534	RD-10508-0P	NIPPLE, PIPE # 6, STRAIGHT FEMALE...	1
12	PAOZZ	4130015215745	62534	RD-5-11435-0P	RECEIVER, LIQUID REF.....	1
13	PAOZZ	4730015265020	62534	RD-5-4035-52	CLAMP, HOSE.....	1
14	PAOZZ	5340015589848	62534	RD-9-10055	MTG KIT, COMPRESSOR.....	1
15	PAOZZ	5305015297316	62534	RD-5-6250-0-35M	.SCREW, CAP, HEXAGON H M10 X 35MM....	1
16	PAOZZ	5310015258620	62534	RD-5-9377-0M	.NUT, SELF-LOCKING, HE M10 X 1.5.....	1
17	PAOZZ	5305015314875	62534	RD-6247-0-1.500M	.SCREW, CAP, HEXAGON H 5/8 X 1 1/2"..	1
18	PAOZZ	5310015314873	62534	RD-5-6135-0M	.WASHER, LOCK 1/2".....	1
19	PAOZZ	5310015314373	62534	RD-5-6138-0M	.WASHER, FLAT M10.....	1
20	PAOZZ	5305000712067	80204	B1821BH05C125N	.SCREW, CAP, HEXAGON H.....	1
21	PAOZZ	5342015314331	62534	RD-9-10049-0P	.BRACKET, ENGINE ACCE.....	1
22	PAOZZ	5305015297949	62534	RD-5-6250-0-40MM	SCREW, CAP, HEXAGON H M10 X 40MM.....	1
23	PAOZZ	4130015217816	62534	RD-5-11393-0P	COMPRESSOR, REFRIGER 24 VOLT.....	1

END OF FIGURE

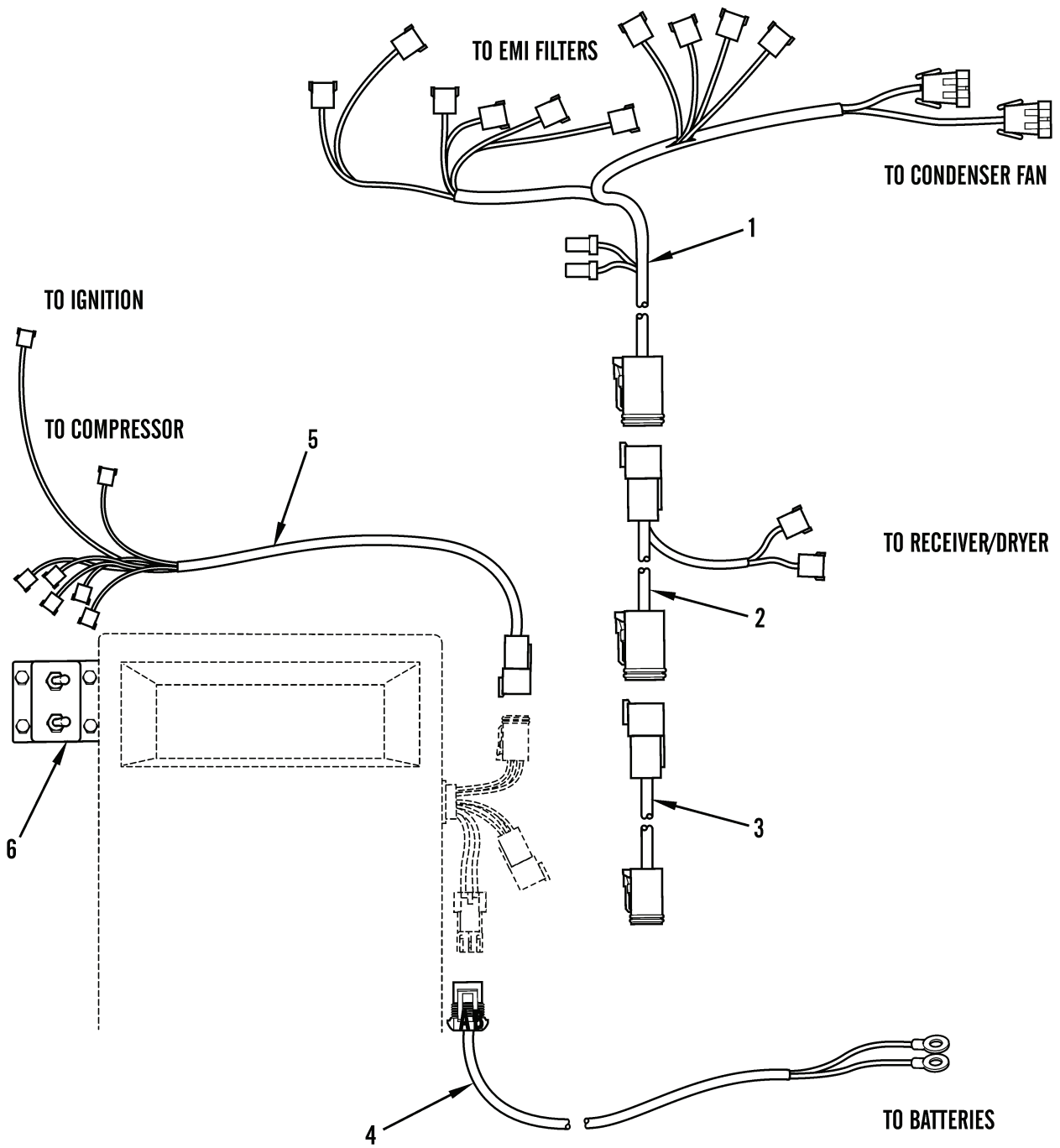

Figure 4. A/C Wiring Harnesses and Panel Switch

(1) ITEM NO	(2) SMR CODE	(3) NSN	(4) CAGEC	(5) PART NUMBER	(6) DESCRIPTION AND USABLE ON CODES (UOC)	(7) QTY
GROUP 3307 SPECIAL PURPOSE KITS						
FIG. 4 A/C WIRING HARNESES AND PANEL SWITCH						
1	PAOZZ	6150015215712	62534	RD-4-5913-0P	WIRING HARNESS, BRAN.....	1
2	PAOZZ	6150015330936	62534	RD-4-5958-0P	WIRING HARNESS, BRAN.....	1
3	PAOZZ	6150015590467	62534	RD-2-4244-0	HARNESS, JUMPER.....	1
4	PAOZZ	6150015590454	62534	RD-2-4526-0	HARNESS, WIRING, BATT.....	1
5	PAOZZ	6150015590487	62534	RD-2-4160-0	HARNESS, WIRING, CLUT.....	1
6	PAOZZ	5930015589358	62534	RD-2-4576-0	SWITCH, PANEL, CONTRO.....	1

END OF FIGURE

0029 00

TB 9-2320-273-13&P-2

(1)	(2)	(3)	(4)	(5)	(6)	(7)
ITEM	SMR			PART		
NO	CODE	NSN	CAGEC	NUMBER	DESCRIPTION AND USABLE ON CODES (UOC)	QTY

GROUP 95 GENERAL USE STANDARDIZED
PARTS
GROUP 9501 HARDWARE SUPPLIES AND
BULK MATERIEL, COMMON

FIG. BULK

1	PAOZZ	4720015239231	62534	RD-5-10504-600M	HOSE, METALLIC #6.....	1
---	-------	---------------	-------	-----------------	------------------------	---

END OF FIGURE

CROSS-REFERENCE INDEXES

		NATIONAL STOCK NUMBER INDEX			
STOCK NUMBER	FIG.	ITEM	STOCK NUMBER	FIG.	ITEM
5305-00-068-7837	1	8			
5310-00-081-4219	1	14			
	2	18			
5306-00-226-4829	1	13			
5310-00-984-3807	1	15			
5945-01-170-6666	1	27			
6685-01-517-4892	1	26			
5305-01-517-9283	2	12			
5310-01-517-9443	2	14			
6150-01-521-4634	1	30			
6150-01-521-5712	4	1			
4130-01-521-5745	3	12			
4140-01-521-6422	2	4			
4130-01-521-6442	1	19			
5915-01-521-6706	2	13			
4130-01-521-7486	1	18			
4130-01-521-7816	3	23			
4710-01-523-0548	1	25			
5306-01-523-1006	2	5			
5310-01-523-1552	1	20			
5305-01-523-1683	2	2			
5305-01-523-1947	1	1			
5340-01-523-1985	1	3			
5340-01-523-2408	2	11			
5305-01-523-2459	1	11			
	2	19			
5310-01-523-2651	2	7			
5970-01-523-3109	2	3			
5310-01-523-3710	2	6			
5310-01-523-3713	1	28			
5340-01-523-8425	1	6			
4720-01-523-9231	BULK	1			
2540-01-523-9277	1	29			
5305-01-524-2260	1	10			
5340-01-525-1931	2	15			
5310-01-525-8620	3	16			
5310-01-525-8946	2	17			
4730-01-526-5020	3	13			
5310-01-528-1391	1	9			
5305-01-529-7316	3	15			
5305-01-529-8067	1	2			
5305-01-529-8296	2	16			
9330-01-531-4309	3	5			
5342-01-531-4331	3	21			
5310-01-531-4373	3	19			
5310-01-531-4873	3	18			
5331-01-533-0281	3	8			
5331-01-533-0282	3	2			
6150-01-533-0936	4	2			
5340-01-554-5536	2	9			

CROSS-REFERENCE INDEXES

CAGEC	PART NUMBER INDEX		FIG.	ITEM
	PART NUMBER	STOCK NUMBER		
80204	B1821BH025C063N	5305-00-068-7837	1	8
80204	B1821BH031C125N	5306-00-226-4829	1	13
62534	B1821BH05C125N		3	20
10988	L118429	5945-01-170-6666	1	27
96906	MS27183-12	5310-00-081-4219	1	14
			2	18
81349	M45913/1-5FG5C	5310-00-984-3807	1	15
62534	RD-10508-0P		3	11
62534	RD-2-4116-0	5340-01-523-8425	1	6
62534	RD-2-4126-0P	5340-01-523-1985	1	3
62534	RD-2-4129-0P	4130-01-521-6442	1	19
62534	RD-2-4132-0P	4130-01-521-7486	1	18
62534	RD-2-4150-0		1	4
62534	RD-2-4153-0P	6150-01-521-4634	1	30
62534	RD-2-4160-0		4	5
62534	RD-2-4244-0		4	3
62534	RD-2-4484-0		1	21
62534	RD-2-4495-0		1	22
62534	RD-2-4498-0		1	7
62534	RD-2-4512-0		1	12
62534	RD-2-4526-0		4	4
62534	RD-2-4576-0		4	6
62534	RD-2-4597-0		1	16
62534	RD-4-5886-0	5340-01-523-2408	2	11
62534	RD-4-5913-0P	6150-01-521-5712	4	1
62534	RD-4-5958-0P	6150-01-533-0936	4	2
62534	RD-4-5968-0P	5340-01-525-1931	2	15
62534	RD-4-6060-0P		2	1
62534	RD-4-6096-0		3	10
62534	RD-5-10236-0		1	23
62534	RD-5-10504-DRY		3	7
62534	RD-5-10504-182		3	4
62534	RD-5-10504-600M	4720-01-523-9231	BULK	1
62534	RD-5-10505-218		3	1
62534	RD-5-10507-136		3	9
62534	RD-5-10531-0P		3	6
62534	RD-5-10818-0M	5310-01-525-8946	2	17
62534	RD-5-10825-1-16M	5305-01-523-1947	1	1
62534	RD-5-11015-0		3	3
62534	RD-5-11016-0	5331-01-533-0282	3	2
62534	RD-5-11017-0	5331-01-533-0281	3	8
62534	RD-5-11388-0M	5310-01-523-3710	2	6
62534	RD-5-11390-0-1.5 00M	5306-01-523-1006	2	5
62534	RD-5-11392-0	5310-01-523-2651	2	7
62534	RD-5-11393-0P	4130-01-521-7816	3	23
62534	RD-5-11435-0P	4130-01-521-5745	3	12
62534	RD-5-11437-0		1	24
62534	RD-5-11438-0		1	17
62534	RD-5-11440-0P	6685-01-517-4892	1	26
62534	RD-5-11444-0P	2540-01-523-9277	1	29

CROSS-REFERENCE INDEXES

CAGEC	PART NUMBER	PART NUMBER INDEX		FIG.	ITEM
			STOCK NUMBER		
62534	RD-5-11445-0P		5915-01-521-6706	2	13
62534	RD-5-1212-1-.375			2	10
62534	RD-5-3816-16P		4710-01-523-0548	1	25
62534	RD-5-4035-52		4730-01-526-5020	3	13
62534	RD-5-4133-0		5310-01-528-1391	1	9
62534	RD-5-4665-0M		5340-01-554-5536	2	9
62534	RD-5-5351-1-25M		5305-01-523-2459	1	11
				2	19
62534	RD-5-5381-0		5310-01-523-1552	1	20
62534	RD-5-5630-1-16		5305-01-529-8067	1	2
62534	RD-5-5679-0M		5310-01-517-9443	2	14
62534	RD-5-5857-0			2	8
62534	RD-5-6135-0M		5310-01-531-4873	3	18
62534	RD-5-6138-0M		5310-01-531-4373	3	19
62534	RD-5-6250-0-35M		5305-01-529-7316	3	15
62534	RD-5-6250-0-40MM			3	22
62534	RD-5-6831-0M		5310-01-523-3713	1	28
62534	RD-5-7213-1-.375		5305-01-524-2260	1	10
62534	RD-5-7357-8.5P		5970-01-523-3109	2	3
62534	RD-5-7747-96P		9330-01-531-4309	3	5
62534	RD-5-8222-1-16		5305-01-517-9283	2	12
62534	RD-5-8222-1-22M		5305-01-529-8296	2	16
62534	RD-5-8785-3P		4140-01-521-6422	2	4
62534	RD-5-8980-1-20		5305-01-523-1683	2	2
62534	RD-5-9377-0M		5310-01-525-8620	3	16
62534	RD-6247-0-1.500M			3	17
62534	RD-9-10049-0P		5342-01-531-4331	3	21
62534	RD-9-10055			3	14

INDEX

<i>Subject</i>	<i>Work Package/Page</i>
A	
A/C	
Air Filter Replacement	0010 00-1
Hose Replacement	0020 00-1
Kit Installation Instructions	0027 00-1
System	0002 00-3
System Maintenance	0015 00-1
Troubleshooting Introduction	0011 00-1
Troubleshooting Procedures	0013 00-1
Troubleshooting Symptom Index	0012 00-1
Wiring Harness Replacement	0021 00-1
Abbreviation/Acronym	0001 00-2
C	
Compressor Replacement	0016 00-1
Condenser Replacement	0018 00-1
Corrosion Prevention and Control (CPC)	0001 00-1
D	
Decal and Data Plate Guide	0007 00-1
Description and Use of Operator Controls	0004 00-1
Destruction of Army Materiel to Prevent Enemy Use	0001 00-1
E	
Equipment	
Characteristics, Capabilities, and Features	0002 00-1
Data	0002 00-3
Description and Data	0002 00-1
Evaporator Assembly Maintenance	0017 00-1
Expendable and Durable Items List	0025 00-1
G	
General Information	0001 00-1
General Maintenance Instructions	0014 00-1
I	
Initial Adjustments and Daily Checks	0005 00-1
L	
List of Abbreviation/Acronym	0001 00-2
Location and Description of Major Components	0002 00-1

INDEX - Continued

<i>Subject</i>	<i>Work Package/Page</i>
M	
Maintenance Allocation Chart (MAC)	
Introduction	0023 00-1
Table	0024 00-1
Maintenance Forms, Records, and Reports	0001 00-1
O	
Operating Air Conditioning Kit	0005 00-1
Operation	
In Extreme Temperatures	0006 00-1
Under Unusual Conditions	0006 00-1
Under Usual Conditions	0005 00-1
Operator Controls, Description and Use of	0004 00-1
P	
Preparation for Storage or Shipment	0001 00-1
Preventive Maintenance Checks and Services (PMCS)	
Introduction	0008 00-1
Procedures	0009 00-1
R	
Receiver/Dryer Replacement	0019 00-1
References	0022 00-1
Repair Parts and Special Tools List (RPSTL)	
Figures	0029 00-1
Introduction	0028 00-1
Reporting Equipment Improvement Recommendation (EIR)	0001 00-1
S	
Storage or Shipment, Preparation for	0001 00-1
T	
Theory of Operation	0003 00-1
Torque Limits	0026 00-1

By Order of the Secretary of the Army:

GEORGE W. CASEY, JR.
General, United States Army
Chief of Staff

Official:

JOYCE E. MORROW
Administrative Assistant to the
Secretary of the Army
0806312

DISTRIBUTION: To be distributed in accordance with the initial distribution requirements for IDN: 344838, requirements for TB 9-2320-273-13&P-2.

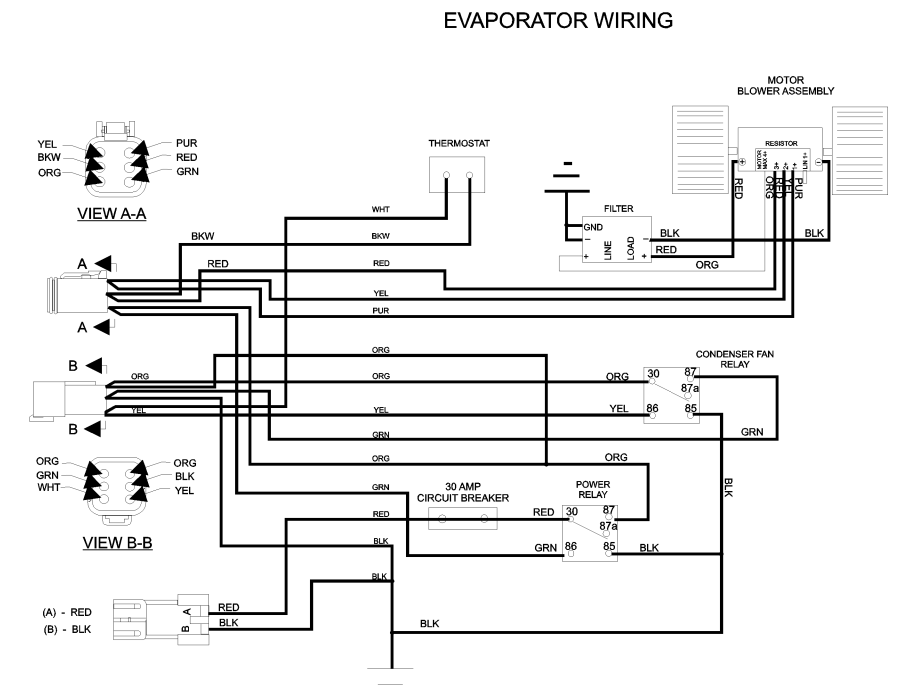
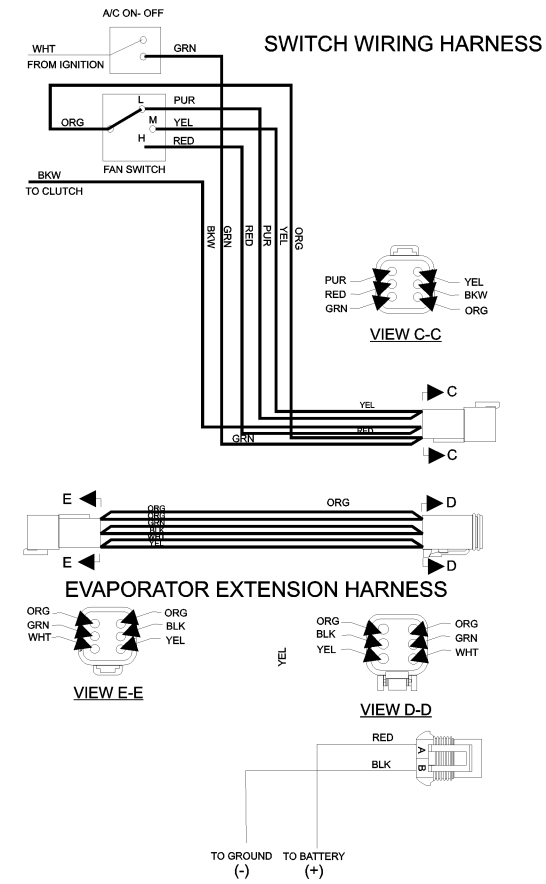
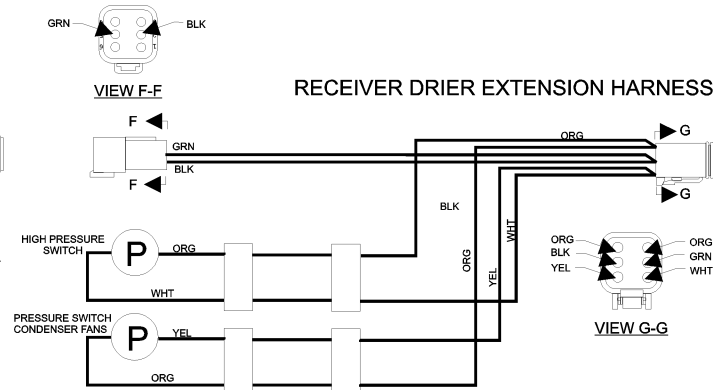
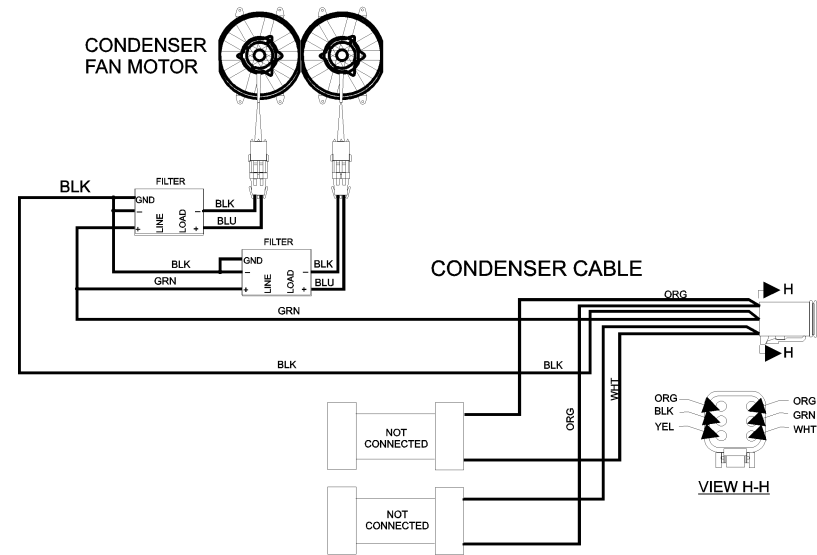

THE METRIC SYSTEM AND EQUIVALENTS

<p>Linear Measure</p> <p>1 Centimeter = 10 Millimeters = 0.01 Meters = 0.3937 Inches 1 Meter = 100 Centimeters = 1000 Millimeters = 39.37 Inches 1 Kilometer = 1000 Meters = 0.621 Miles</p> <p>Weights</p> <p>1 Gram = 0.001 Kilograms = 1000 Milligrams = 0.035 Ounces 1 Kilogram = 1000 Grams = 2.2 Pounds 1 Metric Ton = 1000 Kilograms = 1 Megagram = 1.1 Short Tons</p> <p>Liquid Measure</p> <p>1 Milliliter = 0.001 Liters = 0.0338 Fluid Ounces 1 Liter = 1000 Milliliters = 33.82 Fluid Ounces</p>	<p>Square Measure</p> <p>1 Sq Centimeter = 100 Sq Millimeters = 0.155 Sq Inches 1 Sq Meter = 10,000 Sq Centimeters = 10.76 Sq Feet 1 Sq Kilometer = 1,000,000 Sq Meters = 0.386 Sq Miles</p> <p>Cubic Measure</p> <p>1 Cu Centimeter = 1,000 Cu Millimeters = 0.06 Cu Inches 1 Cu Meter = 1,000,000 Cu Centimeters = 35.31 Cu Feet</p> <p>Temperature</p> <p>$5/9 (^{\circ}\text{F} - 32) = ^{\circ}\text{C}$ 212° Fahrenheit is equivalent to 100° Celsius 90° Fahrenheit is equivalent to 32.2° Celsius 32° Fahrenheit is equivalent to 0° Celsius $9/5 \text{ C}^{\circ} + 32 = \text{F}^{\circ}$</p>
--	--

APPROXIMATE CONVERSION FACTORS

To Change	To	Multiply By
Inches	Centimeters	2.540
Feet	Meters	0.305
Yards	Meters	0.914
Miles	Kilometers	1.609
Sq Inches	Sq Centimeters	6.451
Sq Feet	Sq Meters	0.093
Sq Yards	Sq Meters	0.836
Sq Miles	Sq Kilometers	2.590
Acres	Sq Hectometers	0.405
Cubic Feet	Cubic Meters	0.028
Cubic Yards	Cubic Meters	0.765
Fluid Ounces	Milliliters	29.573
Pints	Liters	0.473
Quarts	Liters	0.946
Gallons	Liters	3.785
Ounces	Grams	28.349
Pounds	Kilograms	0.454
Short Tons	Metric Tons	0.907
Pound-Feet	Newton-Meters	1.356
Pounds per Sq Inch	Kilopascals	6.895
Miles per Gallon	Kilometers per Liter	0.425
Miles per Hour	Kilometers per Hour	1.609

To Change	To	Multiply By
Centimeters	Inches	0.394
Meters	Feet	3.280
Meters	Yards	1.094
Kilometers	Miles	0.621
Sq Centimeters	Sq Inches	0.155
Sq Meters	Sq Feet	10.764
Sq Meters	Sq Yards	1.196
Sq Kilometers	Sq Miles	0.386
Sq Hectometers	Acres	2.471
Cubic Meters	Cubic Feet	35.315
Cubic Meters	Cubic Yards	1.308
Milliliters	Fluid Ounces	0.034
Liters	Pints	2.113
Liters	Quarts	1.057
Liters	Gallons	0.264
Grams	Ounces	0.035
Kilograms	Pounds	2.205
Metric Tons	Short Tons	1.102
Newton-Meters	Pound-Feet	0.738
Kilopascals	Pounds per Sq Inch	0.145
Kilometers per Liter	Miles per Gallon	2.354
Kilometers per Hour	Miles per Hour	0.621

